

## **Washoe County District Board of Health Meeting Notice and Agenda**

### **Members**

Kitty Jung, Chair  
Dr. John Novak, Vice Chair  
Oscar Delgado  
Dr. George Hess  
Kristopher Dahir  
Michael D. Brown  
Tom Young

**Thursday, May 24, 2018  
1:00 p.m.**

**Washoe County Administration Complex  
Commission Chambers, Building A  
1001 East Ninth Street  
Reno, NV**

---

**An item listed with asterisk (\*) next to it is an item for which no action will be taken.  
1:00 p.m.**

- 1. \*Roll Call and Determination of Quorum**
- 2. \*Pledge of Allegiance**
- 3. \*Public Comment**

Any person is invited to speak on any item on or off the agenda during this period. Action may not be taken on any matter raised during this public comment period until the matter is specifically listed on an agenda as an action item.

- 4. Approval of Agenda – (For possible action)  
May 24, 2018**
- 5. \*Recognitions**

**A. Promotions**

- i. Jennifer Pierce – Principal Acct Clerk to Fiscal Compliance Officer - AHS
- ii. Kelly Verling – Public Health Nurse I to Public Health Nurse II - CCHS

**B. New Hires**

- i. Tyler Henderson, 5/14/18, Environmental Health Trainee – EHS

**C. Resolution of Appreciation**

- i. Michele C. Dennis, P.E. - 10/27/1999 - 10/23/2017, Sewage, Wastewater and Sanitation Hearing Board Member
- ii. Steven H. Brigman, P.E. - 10/27/1999 - 10/23/2017, Sewage, Wastewater and Sanitation Hearing Board Member

**D. Accomplishments**

- i. Kelli Goatley-Seals, Community Partner Collaboration Award from UNR School of Community Health Sciences
- ii. Washoe County Health District, Spread Health Award from UNR School of Community Health Sciences

**6. Proclamations - (For possible action)**

- A. Emergency Medical Services Week  
Accepted by: Christina Conti

**7. Consent Items – (For possible action)**

Matters which the District Board of Health may consider in one motion. Any exceptions to the Consent Agenda must be stated prior to approval.

A. Approval of Draft Minutes – (For possible action)

- i. April 26, 2018

B. Budget Amendments/Interlocal Agreements – (For possible action)

- i. Approve Subgrant Amendment #2 from the Nevada Department of Health and Human Services, Division of Public and Behavioral Health effective July 1, 2018 through June 30, 2019 in the amount of \$284,986.00 (no required match) in support of the Community and Clinical Health Services Division (CCHS) Immunization Program Internal Orders #10029 and #11319 and authorize the District Health Officer to execute the Subgrant Amendment.

Staff Representative: Nancy Kerns Cummings

- ii. Accept cash donation in the amount of \$5,000 from Arctica Ice Sales to purchase Long Acting Reversible Contraceptives (LARCs) to help decrease unintended pregnancy rates; approve amendments totaling an increase of \$5,000 in both revenue and expense to the FY18 Arctica Ice Donation budget, IO# 20424.

Staff Representative: Nancy Kerns Cummings

C. Possible reappointment of Dr. Andrew Michelson, Emergency Room Physician, to the Regional Emergency Medical Services Advisory Board - (For possible action)

Staff Representative: Kevin Dick

D. Recommendation to uphold the recommendation of the Sewage, Wastewater, and Sanitation Hearing Advisory Board with conditions for Variance #H18-0001VARI for APN 017-123-05, owned by Mike Fritz. - (For possible action)

Staff Representative: Jim English

E. Acknowledge receipt of the Health Fund Financial Review for April, Fiscal Year 2018 – (For possible action)

Staff Representative: Anna Heenan

**8. \*Presentation on Renown’s Community Benefits Plan**

Presented by: Dr. Anthony Slonim, Renown CEO

**9. Review, discussion and possible adoption of the Business Impact Statement regarding Proposed Revisions to the District Board of Health Regulations Governing Air Quality Management, Sections 020.040 (Civil Fines and Penalties) and 020.042 (Criminal Fines and Penalties) with a finding that the revised regulations do not impose a direct and significant economic burden on a business; nor do the revised regulations directly restrict the formation, operation or expansion of a business; and set a public hearing for possible adoption of the proposed revisions to the Regulations for June 28, 2018 at 1:00 pm. . – (For possible action)**

Staff Representative: Charlene Albee

## 10. Regional Emergency Medical Services Authority

Presented by: JW Hodge

- A. Review and Acceptance of the REMSA Operations Report for April, 2018 – **(For possible action)**
- B. \*Update of REMSA’s Public Relations during April, 2018

## 11. \*Staff Reports and Program Updates

### A. Air Quality Management, Charlene Albee, Director

Program Update, Divisional Update, Program Reports

### B. Community and Clinical Health Services, Steve Kutz, Director

Program Report – Teen Pregnancy Prevention Month; Divisional Update –Client Satisfaction Survey Results; Nevada Childhood Lead Poisoning Prevention Program; Data & Metrics; Program Reports

### C. Environmental Health Services, Chad Westom, Director

Environmental Health Services (EHS) Division and Program Updates – Child Care, Community Development, Food, Land Development, Safe Drinking Water, Schools, Vector-Borne Disease and Waste Management

### D. Epidemiology and Public Health Preparedness, Dr. Randall Todd, Director

Program Updates for Communicable Disease, Public Health Preparedness, Vital Statistics, and Emergency Medical Services

### E. Office of the District Health Officer, Kevin Dick, District Health Officer

District Health Officer Report – FY19 Budget, Water Projects, Public Health Accreditation, Community Health Improvement Plan, Truckee Meadows Healthy Communities, Quality Improvement Team, Workforce Development, Smoke Free Workplaces, REMSA Board Resignation, New CCHS Fees, Brazilian Delegation, Other Events and Activities and Health District Media Contacts.

## 12. \*Board Comment

Limited to announcements or issues for future agendas.

## 13. \*Public Comment

Any person is invited to speak on any item on or off the agenda during this period. Action may not be taken on any matter raised during this public comment period until the matter is specifically listed on an agenda as an action item.

## 14. Adjournment – **(For possible action)**

---

**Possible Changes to Agenda Order and Timing:** Items on the agenda may be taken out of order, combined with other items, withdrawn from the agenda, moved to the agenda of another later meeting; moved to or from the Consent section, or they may be voted on in a block. Items with a specific time designation will not be heard prior to the stated time, but may be heard later. Items listed in the Consent section of the agenda are voted on as a block and will not be read or considered separately unless withdrawn from the Consent agenda.

**Special Accommodations:** The District Board of Health Meetings are accessible to the disabled. Disabled members of the public who require special accommodations or assistance at the meeting are requested to notify Administrative Health Services in writing at the Washoe County Health District, PO Box 1130, Reno, NV 89520-0027, or by calling 775.328.2416, 24 hours prior to the meeting.

**Public Comment:** During the “Public Comment” items, anyone may speak pertaining to any matter either on or off the agenda, to include items to be heard on consent. For the remainder of the agenda, public comment will only be heard during items that are not marked with an asterisk (\*). Any public comment for hearing items will be heard before action is taken on the item and must be about the specific item being considered by the Board. In order to speak during any public comment, each speaker must fill out a “Request to Speak” form and/or submit comments for the record to the Recording Secretary. Public comment and

presentations for individual agenda items are limited as follows: fifteen minutes each for staff and applicant presentations, five minutes for a speaker representing a group, and three minutes for individual speakers unless extended by questions from the Board or by action of the Chair.

**Response to Public Comment:** The Board of Health can deliberate or take action only if a matter has been listed on an agenda properly posted prior to the meeting. During the public comment period, speakers may address matters listed or not listed on the published agenda. The *Open Meeting Law* does not expressly prohibit responses to public comments by the Board of Health. However, responses from the Board members to unlisted public comment topics could become deliberation on a matter without notice to the public. On the advice of legal counsel and to ensure the public has notice of all matters the Board of Health will consider, Board members may choose not to respond to public comments, except to correct factual inaccuracies, ask for Health District Staff action or to ask that a matter be listed on a future agenda. The Board of Health may do this either during the public comment item or during the following item: “Board Comments – Limited to Announcement or Issues for future Agendas.”

**Posting of Agenda; Location of Website:**

Pursuant to NRS 241.020, Notice of this meeting was posted at the following locations:

Washoe County Health District, 1001 E. 9th St., Reno, NV  
Reno City Hall, 1 E. 1st St., Reno, NV  
Sparks City Hall, 431 Prater Way, Sparks, NV  
Washoe County Administration Building, 1001 E. 9th St, Reno, NV  
Downtown Reno Library, 301 S. Center St., Reno, NV  
Washoe County Health District Website [www.washoecounty.us/health](http://www.washoecounty.us/health)  
State of Nevada Website: <https://notice.nv.gov>

**How to Get Copies of Agenda and Support Materials:** Supporting materials are available to the public at the Washoe County Health District located at 1001 E. 9<sup>th</sup> Street, in Reno, Nevada. Ms. Laura Rogers, Administrative Secretary to the District Board of Health is the person designated by the Washoe County District Board of Health to respond to requests for supporting materials. Ms. Rogers is located at the Washoe County Health District and may be reached by telephone at (775) 328-2415 or by email at [lrogers@washoecounty.us](mailto:lrogers@washoecounty.us). Supporting materials are also available at the Washoe County Health District Website [www.washoecounty.us/health](http://www.washoecounty.us/health) pursuant to the requirements of NRS 241.020.



# *Proclamation*

## **Emergency Medical Services Week**

WHEREAS, emergency medical services personnel are called upon to help others through one of the most frightening times of their lives; and

WHEREAS, emergency medical services is a vital public service with personnel ready to provide lifesaving care to the community 24 hours a day, seven days a week; and

WHEREAS, access to quality emergency care dramatically improves the survival and recovery rate of those who experience sudden illness or injury; and

WHEREAS, the emergency medical services system consists of men and women in both the public and private sectors – including emergency physicians, emergency nurses, emergency dispatchers, emergency medical technicians, paramedics, firefighters, educators, administrators, volunteers, and others throughout our healthcare system – who work together to ensure those in need receive the highest level of emergency service; and

WHEREAS, the EMS commitment to patient care throughout Northern Nevada has been an integral factor in our safety and security; and

WHEREAS, Washoe County is proud to have organizations such as Reno Fire Department, Sparks Fire Department, Truckee Meadows Fire Protection District, North Lake Tahoe Fire Protection District, Reno Tahoe Airport Authority Fire Department, Pyramid Lake Fire/EMS, Gerlach Volunteer Fire Department, REMSA and Care Flight operating throughout the region to ensure the highest quality of patient care and community support; and

WHEREAS, the members of emergency medical services teams, whether career or volunteer, engage in thousands of hours of specialized training and continuing education to enhance their lifesaving skills; and

WHEREAS, it is appropriate to recognize the value and the accomplishments of emergency medical services providers by designating Emergency Medical Services Week; now

NOW, THEREFORE, be it resolved, that the Washoe County District Board of Health does hereby proclaim the week of May 20-26, 2018, as

### **Emergency Medical Services Week**

with the theme

### **EMS STRONG: Stronger Together**

in Washoe County, Nevada.

**ADOPTED** this \_\_\_<sup>th</sup> day of May 2018

---

Kitty Jung, Chair  
Washoe County District Board of Health

## **Washoe County District Board of Health Meeting Minutes**

### **Members**

Kitty Jung, Chair  
Dr. John Novak, Vice Chair  
Oscar Delgado  
Dr. George Hess  
Kristopher Dahir  
Michael D. Brown  
Tom Young

**Thursday, April 26, 2018  
1:00 p.m.**

**Washoe County Administration Complex  
Commission Chambers, Building A  
1001 East Ninth Street  
Reno, NV**

---

### **1. \*Roll Call and Determination of Quorum**

Vice Chair Novak called the meeting to order at 1:03 p.m.

The following members and staff were present:

Members present: Dr. John Novak, Vice Chair

Michael Brown  
Oscar Delgado  
Dr. George Hess  
Kristopher Dahir  
Tom Young

Members absent: Kitty Jung, Chair

**Ms. Rogers verified a quorum was present.**

Staff present: Kevin Dick, District Health Officer, ODHO  
Leslie Admirand, Deputy District Attorney  
Charlene Albee  
Steve Kutz  
Chad Westom  
Dr. Randall Todd  
Christina Conti  
Stephanie Chen  
Yann Ling-Barnes

### **2. \*Pledge of Allegiance**

Ms. Albee led the pledge to the flag.

Mr. Dick requested a moment of silence for Ms. Darleen Bidlake, Washoe County Health District employee, who had passed away unexpectedly that morning.

### **3. \*Public Comment**

**As there was no one wishing to speak, Vice Chair Novak closed the public comment period.**

#### **4. Approval of Agenda**

April 26, 2018

Mr. Brown moved to approve the agenda for the April 26, 2018, District Board of Health regular meeting. Mr. Dahir seconded the motion which was approved six in favor and none against.

#### **5. Recognitions**

##### **A. Years of Service**

- i. David Orozco, 25 years, Hired 4/19/1993 - EHS
- ii. Daniel Inouye, 20 years, Hired 4/24/1998 – AQM

Mr. Dick informed that Mr. Inouye has been with the Health District for twenty years and is the Branch Chief for Monitoring and Planning in the Air Quality Management Division, and congratulated him on his years of service.

Mr. Dick stated that Mr. Orozco was unable to be present at this meeting, but wanted to congratulate him on his years of service and his upcoming retirement.

##### **B. Retirements**

- i. David Orozco, 5/1/2018, Environmental Health Specialist – 25 years, EHS

Mr. Orozco was not able to be present at this meeting.

##### **C. New Hires**

- i. Jennifer Pierce, Principal Account Clerk, 4/16/2018 – AHS

Ms. Heenan stated it was her pleasure to introduce Ms. Pierce as the new Principal Account Clerk in Administrative Health Services. Ms. Heenan informed that Ms. Pierce had previously worked in the Treasurer's Office and more recently at the Sheriff's Office as the Principal Account Clerk. She expressed that the Health District is very lucky to have her, and that Ms. Pierce brings with her a wealth of knowledge and that she looks forward to working with her.

##### **Shining Star**

- i. Jessi Salim – EHS
- ii. Blair Hedrick – Vitals, EPHP
- iii. Victoria Stebbins – Vitals, EPHP
- iv. Carmen Mendoza – EPHP

Mr. Dick informed that the Shining Star Program is an employee recognition program for staff that provide excellent customer service to the public or within the Health District.

He stated that Ms. Salim was unable to attend this meeting, but that she has been recognized by customers for her customer service skills.

Mr. Dick explained that the next three Shining Stars are the entire EPHP Vitals Program staff. He introduced Ms. Stebbins with four recognition each and Ms. Mendoza who has a total of six Shining Star Awards. Ms. Hedrick who had received four recognitions was unable to attend.

#### **6. Proclamations**

National Bike Month and Bicycle Safety Month and Washoe County Bike Week

Mr. Dick read the Proclamation. Ms. Ling-Barnes informed that the Bike Week is organized by the Truckee Meadows Bicycle Alliance, of which she and Ms. Chen are members. She encouraged all those present to participate if possible, and provided the website address, listed below:

<https://bikewashoe.org/>

Ms. Chen stated that, as a Health Educator for the Chronic Disease Prevention Program, she is happy to support and promote Bike Month and Bike Week and encourage Washoe County residents to be active in their lifestyles. She informed that, during Bike Week, there will be numerous events organized by the Truckee Meadows Bicycle Alliance and invited everyone to participate.

**Mr. Brown moved to adopt the Proclamation for National Bike Month and Bicycle Safety Month and Washoe County Bike Week. Mr. Young seconded the motion which was approved six in favor and none against.**

## 7. Consent Items

Matters which the District Board of Health may consider in one motion. Any exceptions to the Consent Agenda must be stated prior to approval.

### A. Approval of Draft Minutes

- i. March 22, 2018

### B. Budget Amendments/Interlocal Agreements

- i. Approve a Subgrant Award from the State of Nevada Department of Health and Human Services, Division of Public & Behavioral Health retroactive to April 1, 2018 through March 31, 2019 in the total amount of \$168,597.33 (no required match) in support of the Community and Clinical Health Services Division (CCHS) Ryan White Part B Program IO#11479 and authorize the District Health Officer to execute the Subgrant Award.

Staff Representative: Nancy Kerns Cummins

- ii. Approve a Notice of Award from the U.S. Department of Health and Human Services, Public Health Service extending the current award through August 31, 2018 and granting an additional \$370,000 (\$37,000 Health District cash match) in support of the Community and Clinical Health Services Division (CCHS) Title X Family Planning Grant Program, IO# 11304.

Staff Representative: Nancy Kerns Cummins

- iii. Retroactive approval of Grant Agreement #A-00905418-0 from the U.S. Environmental Protection Agency (EPA) for funding in the amount of \$547,651 for the period 10/1/17 through 9/30/18 for the Air Quality Management, EPA Air Pollution Control Program, IO 10019.

Staff Representative: Patsy Buxton

- C. Approve an Interlocal Agreement between the Washoe County Health District and Washoe County through its Sheriff's Office to provide family planning services to female detainees for the period upon ratification by the governing parties through June 30, 2019 with automatic renewal for two successive one-year periods for a total of three years on the same terms and if approved, authorize the Chair to execute the Agreement.

Staff Representative: Nancy Kerns Cummins



- D. Retroactive Approval of Assistance Amendment PM-00T56401-6 from the U.S. Environmental Protection Agency (EPA) for the period 4/1/18 through 3/31/19 for the Air Quality Management, EPA Air Pollution Control Program, IO 10021.  
Staff Representative: Patsy Buxton
- E. Recommendation to appoint Nick Vestbie, P.E., as a member to the Sewage, Wastewater and Sanitation Hearing Board (SWS Board) and Ray Pezonella, P.E. and Matt Smith as alternates to the SWS Board and reappoint Matt Buehler as a member to the Sewage, Wastewater and Sanitation Hearing Board (SWS Board) for a three-year term beginning April 26, 2018 and ending April 25, 2021.  
Staff Representative: James English
- F. Approval of Amendment #1 to the Interlocal Agreement For Emergency Medical Services Oversight between the Washoe County Health District, Washoe County, the Truckee Meadows Fire Protection District, the City of Reno and the City of Sparks to allow representatives of the Advisory Board authority to designate an alternate to replace the representative in the representative's absence from meetings of the Advisory Board with alternates being a City or County Assistant Manager or Health District Division Director.  
Staff Representative: Kevin Dick
- G. Acknowledge receipt of the Health Fund Financial Review for March, Fiscal Year 2018  
Staff Representative: Anna Heenan

**Dr. Hess moved to accept the Consent Agenda. Mr. Delgado seconded the motion which was approved six in favor and none against.**

## **8. Regional Emergency Medical Services Authority**

Presented by: Paul Burton

- A. Review and Acceptance of the REMSA Operations Report for March, 2018

Mr. Burton introduced himself as Director of EMS Operations and stated that Mr. Dow and Mr. Hodge were not able to be present at this meeting due to conflicting schedules, but would be presenting at the next District Board of Health Meeting.

He stated that he was available to answer questions regarding the March Compliance Review.

**Mr. Brown moved to accept the REMSA Operations Report for March 2018. Mr. Dahir seconded the motion which was approved six in favor and none against.**

- B. \*Update of REMSA's Public Relations during February 2018

Mr. Burton informed February was filled with community outreach and media relations opportunities around heart health and CPR and AED awareness. He stated that Education Manager, Ms. Cindy Green was featured on a KRNV broadcast where she discussed heart health and how to administer hands only CPR.

Mr. Burton stated that the Education Department hosted a hands only CPR Event at Meadowood Mall, Hometown Health, Discovery Museum and the Little Flower Church during a Spanish Language Outreach Event.

- C. \*Update of REMSA's Public Relations during March, 2018

Mr. Burton informed that in March, there were a variety of opportunities for the public. Ms. Green provided an interview about the use of Narcan and how REMSA's Communications Specialists can help 911 callers administer the drug until paramedics arrive.

Mr. Burton stated that Univision, a local Spanish language television station, participated in a ride-along with a Spanish-speaking crew. He informed that the reporter spent a four-hour shift with the crew and conducted an interview in Spanish only. He stated the story was very positive and had a recruiting angle to it.

Mr. Burton informed that REMSA participated in the Stop the Bleed Event with Renown Trauma Services and Nevada Air National Guard.

Mr. Burton stated that REMSA Ground Crews began hosting local hospital personnel for ride-alongs, and, as community partners, it was important for the Community Healthcare Team to experience the healthcare continuum from the point of the incident involving REMSA to the hospital. He explained that REMSA's healthcare providers do clinical rotations on various units within a hospital, but it's rare to have the hospital healthcare providers have the opportunity to spend time in the field. He informed that the ride-alongs have been very well received by the hospital staff.

Mr. Burton informed that REMSA welcomed a group of Wooster High School comprehensive life skill students for a special tour, and that Telecommunications Manager Ms. Christine Barton led the students through a dispatch center, ambulance and Care Flight helicopter, learned what to expect when you call 911 and how ambulances respond throughout the community.

Because REMSA knows that social media is an important way to engage the public, Mr. Burton announced that REMSA has been putting additional strategies into their Facebook and LinkedIn sites for their followers, and detailed those additions.

Mr. Burton informed that the Nurse Health Line received its reaccreditation from the International Academies of Emergency Dispatchers. He explained that the REMSA Nurse Health Line was the first in the world to be accredited and is one of only two accredited nursing health lines across the globe.

Vice Chair Novak congratulated Mr. Burton and REMSA for their Nurse Health Line being one of only two in the world that are accredited.

Mr. Dahir informed that he is on the Nevada ALS Board and of the walk that organization has planned to be held on May 5<sup>th</sup>, and asked if REMSA would be interested in participating. He opined that they are heroes and that it would be good for the public to be informed of the vital service they provide.

**9. \*Regional Emergency Medical Services Advisory Board April Meeting Summary**  
Staff Representative: Christina Conti

Ms. Conti informed that, since the EMSAB Meeting held earlier in April, the upgrade for the REMSA side of the CAD has been scheduled to occur on April 30<sup>th</sup> and should allow the City of Reno and REMSA to be in communication by June.

Regarding the 911 PSA project, Ms. Conti presented two formats of educational advertisements to inform residents of the importance of calling 911 only when appropriate. These messages were produced with both English and Spanish versions and will begin to be shown in various media outlets in mid-May.

The website, [thinkbeforeyoudial.com](http://thinkbeforeyoudial.com), will route visitors to the pre-existing 911 education page that was developed with regional partners last year and is being updated to be more user friendly for mobile device users. (link below) Another feature of this site will be the ability to report incidents directly from this site. This part of the website has not gone live yet.

[www.thinkbeforeyoudial.com](http://www.thinkbeforeyoudial.com)

Ms. Conti informed that the Regional Protocols went into effect on April 1<sup>st</sup>, with eight different agencies in the region now using the same protocols for pre-hospital care.

Also included in the packet for the DBOH Members are the Mid-Year Data Report and an informational paper on the Automatic Vehicle Locator system.

Mr. Dahir inquired if the increased incidence of vehicles being used as weapons is a discussion that is occurring in the EMSAB meetings, and if there might be grant money available to make our community safer.

Ms. Conti informed that there are Multi-Casualty Incident Plans for the region, and that Mass Gathering Guidelines are being revised to lower the number of attendees at a gathering to have EMS personnel on sight, but that the prevention of this type of incident would probably fall outside the scope of their program.

Vice Chair Novak inquired if there is a phone number for REMSA's Nurse Hotline on the 911 Education site, and Ms. Conti confirmed that all non-emergency numbers are there.

Mr. Delgado requested information on protocol for the care of non-emergent patients seeking care at an emergency room. Ms. Conti informed that, regarding the Record Street example given by Mr. Delgado, there had been meetings with REMSA and Reno Fire initially for the Franchise Map Review and detailed possible options to reduce the number of 911 calls at that location.

Mr. Dick informed of a comment he made at the EMS Advisory Board Meeting in regards to the campaign to reduce unnecessary 911 calls. He stated that, although the Health District has invested in this initiative, they don't receive economic benefit from that contribution. He informed that REMSA provides in-kind contribution toward that effort as well, and that it is the local jurisdictions and hospitals that receive the economic benefit. He opined that this campaign will require a long term effort to change behaviors in the community and will require participation from each of the jurisdictions and the hospitals contributing toward a larger, more effective campaign.

Ms. Conti informed that EMS had asked on two separate occasions for contribution from the partners to support the broadcast of the promotion they have prepared. She explained that research shows that it takes twelve to eighteen months for progress to be shown, and that REMSA is the only one to have contributed to date.

Mr. Dahir inquired who it was in the cities that had been contacted with this ask; Ms. Conti informed that it is the Fire Chiefs and Dispatch Supervisors that were contacted as Committee Members.

Mr. Delgado requested Ms. Conti to reach out to him to move forward with this request.

**10. Discussion and possible action to approve a permit fee accommodation such as a payment plan, adjustment of fee due date, or other accommodation as determined by the Board for the Food Truck permittee, Sunshine Ice Cream (Permit # F010144), due to the seasonal nature, product type and financial considerations of the operation per Sunshine Ice Cream's Owner's March 22, 2018 public comment request. - (For possible action)**

Staff Representative: Chad Westom

Mr. Westom informed that this agenda item results from a public comment made at the March 22, 2018 DBOH Meeting by Joseph Williams, owner of Sunshine Ice Cream Food Truck, regarding his opinion that the permit fee to operate his food truck was unreasonable and that he was struggling to pay the fee.

Mr. Westom informed that this fee was established by the District Board of Health and any changes in the payment amount are a policy decision and are to be made by the DBOH, noting that this would be a stand-alone situation.

Mr. Westom explained that they did evaluate the fee and contacted Ms. Admirand for legal counsel, and that staff recommends the Board discuss whether they want to provide

direction to make any changes to the collection of the Sunshine Ice Cream permit fee. He provided options the Board may wish to consider.

Dr. Hess stated he could understand that Mr. Williams could have difficulty with payment of the fee due to his food truck operation being seasonal. He inquired if the fee was the same for all food trucks.

Mr. Westom explained that the food truck fees are the same for all food trucks regardless of size of the truck or product sold and are calculated on an average of the costs of inspection times and food truck related activities in the Environmental Services Division. He informed the fee includes the cost of licensing and inspecting the vehicle and the food truck depot that the vehicle is required to leave from and return to and inspection of the supplies.

Dr. Hess inquired if all food trucks paid the same amount in February. Mr. Westom confirmed the amount was the same, but the payment due date varies depending on the business's start date.

Dr. Hess inquired if the due date could be changed, and Ms. Admirand opined that it would be a decision for the District Health Officer and the District Board of Health, and that it was not a legal decision. She informed that the inspection is required annually, but the payment due date is a policy decision.

Mr. Dick stated that, as the District Health Officer, he did not believe that he has the authority to change payment due dates, but that it would require policy direction from the DBOH. He opined that it is feasible to adjust the payment date that is based upon the original application date for this annual permit, but if the Board was to provide direction to staff to change the due date, the potential risk could be inability to collect the fee should the business fold before payment is made.

Mr. Dahir expressed concern that any action on this request could set precedent, and that the initial fee would be higher after moving the due date to a point later in the year. He opined that waiving the fee or a portion of it is not a wise decision, and that the DBOH needs to be cautious in any decision made on this request.

Mr. Westom informed that Mr. Williams did pay the fee by the due date for this year.

Dr. Hess inquired when Mr. Williams' season would begin for his food truck. Mr. Westom informed that Mr. Williams can begin selling ice cream in some years as early as April, but most commonly by May.

Mr. Young inquired if other jurisdictions had a graduated fee structure to accommodate the various types of food trucks. Mr. Westom stated that there are other models of operation concerning food trucks. He informed that data is being collected as a basis to confirm that the fees collected are in alignment with related expenses and will use this information and other models of operation as a basis in FY19-20 for possible change to the fee structure.

Mr. Westom stressed that any decision made on this item only applies to Sunshine Ice Cream. He indicated that the analysis that EHS conducted for the time and effort required for Sunshine's truck and depot fee is within the ballpark of the other food truck permit fees charged.

**Mr. Dahir moved that the District Board of Health take no action for a permit fee accommodation for the Food Truck permittee, Sunshine Ice Cream (Permit # F010144). Mr. Delgado seconded the motion which was approved six in favor and none against.**

Mr. Young opined it unwise to provide preferential treatment for any vendor, and that fee issues could possibly be addressed in the future for seasonal food trucks.

Mr. Delgado stated that he supports flexibility for the various types of entrepreneurs in the community, but agreed that adjustment to the fee structure is a separate and more in-depth conversation.

## **11. \*Staff Reports and Program Updates**

### **A. Air Quality Management, Charlene Albee, Director**

Program Update, Divisional Update, Program Reports

Ms. Albee presented a video advertising the educational program for students through the Alliance for Climate Education. She informed that this group provides entire lesson plans online for schools to use in the class room and the tools to empower students in their efforts to make a difference.

Ms. Albee informed that Air Quality Management will be promoting this program throughout the community to any schools, children's groups or organizations, and stated that it supports AQM's Ozone Advance Program through their Outreach and Education Program.

Ms. Albee informed that she attended the Reno City Council Meeting held on April 25<sup>th</sup> to be present for the discussion regarding the potential sale of property where AQM's Reno3 monitoring site is located. Ms. Albee stated that they are working closely with the city to find another location that meets EPA siting requirements.

At that meeting, Ms. Albee informed that she had the opportunity to meet with the developers and talk with City of Reno staff, and thanked Councilman Delgado for his assistance in helping her access the podium when she needed to speak on the item.

Ms. Albee informed that City of Reno Assistant City Manager Bill Thomas discussed the possibility of the City of Reno assisting in finding a location for a dedicated monitoring site to hopefully prevent any future need to relocate it again. She stated that the developer was very supportive in their understanding of the timeline it will take to relocate the monitoring site, and that their development could begin in approximately nine months.

Ms. Albee explained that EPA has already been notified that this relocation would occur and will proceed to obtain initial approval of the new site when identified, which will help the City of Reno in the dedication of this land. She explained the many steps required for this process.

Mr. Delgado stated that Ms. Albee did a great job in outlining the importance of working with the developers and making sure that data collection was uninterrupted in the move of the monitoring site for air quality control purposes. He thanked Ms. Albee for her involvement and education of those present at the meeting.

Ms. Albee informed that the Reno3 site is AQM's Ozone Design Value Site and all of the data collected there went into the Attainment Designation and Exceptional Events Package, so is very important to Air Quality Management.

Mr. Dahir expressed the importance of Health District staff being present for City meetings involving subjects related to their Division to provide their expertise.

Mr. Dahir informed that the entity that may be purchasing the property that the Reno3 monitoring site is located on might also help pay to move the monitoring equipment. Ms. Albee confirmed that the City of Reno had suggested that, as part of the purchase of the property, the relocation expenses could potentially be negotiated into the sale. She stated that she was hopeful this would be the case, and that she announced at the City of Reno meeting that there was not budget authority this year or next year for the expense to move this monitoring site which will cost approximately \$150,000.

Vice Chair Novak inquired who owns the video that was shown for Alliance for Climate Education. Ms. Albee informed that Alliance for Climate Education is a nationwide organization that will provide a Launch Kit for their lessons to any

organization that wishes to use them, and that the video trailer she presented is advertising for this program.

**B. Community and Clinical Health Services, Steve Kutz, Director**

Divisional Update – National STD Awareness Month; National Infant Immunization Week; Annual CCHS Training Day; Data & Metrics; Program Reports

Mr. Kutz stated they were excited to announce that Ms. Howell, Sexual Health Program Coordinator, will be on Ask the Doctor this coming Monday, April 30<sup>th</sup>, as part of National STD Awareness Month, and will be highlighting congenital syphilis.

From his report, Mr. Kutz highlighted the new healthy living mural created in partnership with the Washoe County Health District, City of Reno Housing Authority and Washoe County Schools Glenn Duncan and Trainer Middle School, and that the mural will be unveiled at noon on May 3<sup>rd</sup> at the Reno Housing Authority Offices. He informed that Councilman Delgado, Chair Jung, District Health Officer Mr. Dick, himself and many others would be in attendance and looked forward to the great efforts of the Chronic Disease Prevention Program and the partnership with Reno Housing Authority and the Washoe County School District being highlighted at the press conference.

Also within the Chronic Disease Prevention Program (CDP), Mr. Kutz spoke of their work regarding addressing the health impacts of marijuana in Washoe County, particularly second-hand smoke, and the educational media campaigns being developed around that subject. He informed that CDP has been expanding their partnerships within Washoe County to educate the public regarding the use of marijuana and second-hand smoke.

Regarding his invitation to Ms. Heidi Parker, Executive Director for Immunize Nevada, to speak at either the April or May District Board of Health Meeting, Mr. Kutz informed that she would not be available until the September meeting where it is planned that she will recap Washoe County's recent flu season and discuss the plans for the 2018-2019 flu season outreach and education efforts.

Mr. Delgado informed that he'd received very positive feedback regarding the healthy living mural and that they were able to participate in its creation.

**C. Environmental Health Services, Chad Westom, Director**

Environmental Health Services (EHS) Division and Program Updates – Community Development, Food, Land Development, Safe Drinking Water, Schools, Vector-Borne Disease and Waste Management

Mr. Westom informed that there had been a case of salmonella from tainted Kratom product last week wherein Washoe County Health District's Environmental Health and Epidemiology Programs responded to locations with the product for sale to put that product on hold indefinitely, and that a press release had been issued regarding this incident.

Mr. Westom highlighted his monthly report data is inclusive of 2017 totals for comparison as was requested at the last DBOH Meeting.

Mr. Westom informed that his Division has been working very hard with the land development and community development projects, that their turn-around times are being reduced with staff working very diligently.

Mr. Westom stated that there were staff recognitions that morning for staff regarding their great work in completing over 2,000 routine inspections in the first quarter of 2018.

Mr. Dahir inquired if it is anticipated there will be need for additional mosquito abatement chemicals in the coming season. Mr. Westom informed that he had been

working with Mr. Shaffer, Vector Supervisor, to develop a schedule for application and chemicals to be used, and expects there to have been enough budgeted at this time for abatement activities through the season.

Vice Chair Novak inquired whether spray or pellets were being used for abatement. Mr. Dick informed that the products used are the larvicide, which is a pelletized product that is sprayed from the helicopters and, when West Nile Virus is present in the mosquito population, a liquid pesticide that is aerosolized and sprayed.

Mr. Young congratulated Mr. Westom and EHS for their impressive number of inspections completed in the first quarter of 2018.

Mr. Dick informed that the Kratom issue came to light late on Friday, April 20<sup>th</sup>, and wished to acknowledge the collaborative effort that it took to remove this product from a retailer's shelves that initially had not voluntarily cooperated in doing so. He acknowledged Ms. Admirand for her help in drafting a letter instructing steps the retailer needed to take to cooperate with the Health District, and stated that both the City of Reno Business License and Police Department assisted with leverage to encourage compliance which was achieved. He expressed thanks to all those that brought about the desired outcome.

**D. Epidemiology and Public Health Preparedness, Dr. Randall Todd, Director**

Program Updates for Communicable Disease, Public Health Preparedness, and Emergency Medical Services

Dr. Todd informed that the salmonella found in Kratom products is not unique to our area, and stated that there have been 132 cases of salmonella in thirty-eight states associated with this product.

Dr. Todd explained that the confirmed case of measles was a significant incident due to the rarity of the disease's occurrence. He informed that EPHP, CCHS, EHS and AHS staff all assisted in the effort to control the outbreak.

Dr. Todd informed that the definition of "outbreak" as having more cases of a disease than is expected. With the last case of measles reported in Washoe County having been approximately 1998, no cases of measles are expected here. He stated that measles have been declared eliminated which constitutes twelve or more months without any continuous transmission of measles.

Dr. Todd explained that the cases of measles reported in Washoe County tend to be imported here by persons traveling overseas who are exposed and can potentially infect others that are not immunized. In this recent case, the person had been vaccinated but is one of the small percentage that can contract measles regardless of the vaccination's 97% efficacy. He informed that the person had been exposed to measles in California and detailed the statistics of the incident.

Dr. Todd gave a brief history of measles in the U.S., informing that, before 1963 when the vaccine became available, there were three to four million persons infected with measles per year with between 400 and 500 deaths per year.

Dr. Todd commended the work of all Health District staff who worked to keep the measles outbreak limited to one case.

Dr. Todd stated that he and Dr. Chen were interviewed again regarding their report on the Pan-Resistant New Delhi Metallo-Beta-Lactamase-Producing *Klebsiella pneumoniae* by a German television crew whose report will air sometime in 2019.

Dr. Todd informed that updates to the portion of his report regarding the flu season could be found on the Health District website. He informed that it appears the flu season appears to be in decline and nearing its end.

Mr. Dahir inquired what exactly measles are. Dr. Todd informed that measles is a viral illness with a rash that begins on the face and moves down the rest of the body, and detailed other symptoms. Dr. Todd stated that, when discussing measles, it is usually referring to the Hard measles. He informed that there are also the German measles, a less severe illness.

Dr. Todd explained that the MMR vaccination is for Measles, Mumps and Rubella, and that there were a number of students that had to be excluded from school at the University of Nevada Reno during this case due to them having opted out of the vaccine.

**E. Office of the District Health Officer, Kevin Dick, District Health Officer**

District Health Officer Report – FY19 Budget, Public Health Accreditation, Quality Improvement, Strategic Plan, Water Projects, Traner Middle School Mural, Truckee Meadows Healthy Communities, Workforce Development, Advancing Rural Board of Health Capacity to Improve Public Health in Nevada, Washoe Regional Behavioral Health Policy Board, Other Events and Activities and Health District Media Contacts.

Mr. Dick wished to acknowledge the great cooperation from UNR during this measles case in working with Dr. Hug-English and President Johnson regarding communications to the campus and the exclusion of the unvaccinated students.

Mr. Dick informed that Mr. Ulibarri had placed the Washoe County Health District's 2017 Annual Report on the dais for the Board Members and thanked him for his efforts in developing the report and the Division Directors for their collaboration. He stated there were copies available for anyone in the audience who would like one, and that the report would be distributed more widely within the community.

Mr. Dick stated that the County Manager presented the FY19 Budget to the Board of County Commissioners on April 24<sup>th</sup>. He informed that the budget for the Health District moved forward with the above base requests funded by Health District revenues, including the positions added and supported by revenues within the Health Fund.

Mr. Dick informed that the above base request to fund mosquito abatement efforts for treatment of standing waters left from last year's flooding was not approved. He stated that, if it is found that the additional chemical for larviciding is necessary, the Health District's intention is to go back to the Board of County Commissioners seeking funding as a supplement to the budget during FY19.

Mr. Dick stated that the work for Public Health Accreditation continues and informed that they submitted sample documentation to the Health District's Accreditation Manager with the Public Health Accreditation Board for review and had received feedback, improving the understanding of what's required. He stated that they would continue to work to have all required documents within conformity and submitted by the October 1<sup>st</sup> deadline.

Regarding the water projects review, Mr. Dick informed of news received earlier in the week of an issue between Legislative Council Bureau and Nevada Division of Environmental Protection (NDEP) on the Nevada Department of Administration's Codes (NAC) revisions that were in process, which may delay the schedule for State Environmental Commission (SEC) approval prior to the end of the fiscal year. He stated that he will report on any updates received to the DBOH on this subject.

Mr. Dick informed that the Health District is continuing to work on alternative approaches for how the Health District conducts the regulatory oversight of TMWA, and stated that there is a meeting scheduled for Friday, May 4<sup>th</sup> with NDEP, TMWA and the Health District to formalize an oversight structure. Mr. Dick opined this will be in the form of an interlocal agreement that will be presented to the Boards of the Health



District, NDEP and TMWA for approval.

Mr. Dick stated that the Health District continues to work with Truckee Meadows Healthy Communities in the development of a Community Health Improvement Plan. Mr. Dick informed that he spoke with Dr. Slonim regarding Mr. Delgado's request from the last meeting concerning Renown's Community Benefits contribution. Dr. Slonim was not available to attend this DBOH Meeting, but he requested to attend the May meeting and his presentation will be agendized for that time.

Mr. Dick showed a presentation of the Healthy Living Mural at Traner Middle School and explained that the silhouettes painted on the wall are actually those of Traner Middle School students, painted with images of their favorite healthy foods.

Mr. Dick informed that he had the opportunity to present to the Interim Legislative Committee on Healthcare in a joint presentation including the three local health authorities in Nevada, the State Division of Public and Behavioral Health and the Nevada Public Health Association, and they had been allowed two hours for their presentation. The topics of the presentation included the Public Health infrastructure in Nevada and funding for and future direction of Public Health. Mr. Dick informed that his portion of the presentation was on Public Health 3.0 that he had presented previously to the DBOH in regards to community engagement and working to address social determinants of health. He informed that they proposed the need for more flexible and sustainable funding from the State for Public Health, explaining that the State of Nevada is 50<sup>th</sup> out of 51 states in the union, including the District of Columbia, for Public Health funding per capita. If funding were to be increased to \$3 more per person it would elevate Nevada to 49<sup>th</sup>. Mr. Dick informed that they requested a \$5 increase per capita for Public Health, which would still have Nevada ranked as 49<sup>th</sup> in the union.

Mr. Dick opined that Public Health in Nevada needs that level of funding to allow the ability to support work within the community and to be responsive to the health needs identified in the Community Health Needs Assessment, versus the type of funding that is typically received from the State which is tied to a specific federal program for specific services. He informed that the local health authorities and the Nevada Public Health Association are committed to working together to improve the State's investment in public health.

Mr. Dick informed that, although they were provided two hours, the meeting started late and were still allowed their full two hours and more to present. He stated that the committee was very engaged, more so that he had witnessed previously in his career around Public Health. He informed that the session can be viewed on the archived video on the Nevada Legislature's website for the Interim Healthcare Committee Meeting of April 24<sup>th</sup>.

Dr. Hess inquired who chaired the meeting, and Mr. Dick informed it had been Senator Spearman. He informed that the Interim Healthcare Committee is a mixture of both Assembly and Senators from their Healthcare Committees, and that Senators Ratti and Sprinkle are also on that committee as local representation.

Mr. Dahir inquired what increased benefits would be available in healthcare if funding were increased in Nevada to a higher level.

Mr. Dick informed that Dr. Iser from the Southern Nevada Health District presented on Foundational Public Health and informed the Committee of the work done in Washington State to identify those Foundational Capabilities and cost them out. Dr. Iser proposed Nevada's three local health authorities and the State Division of Public Health work together to identify and cost out those services to then bring back their findings to

the Legislature to consider.

Mr. Dick stated that the ask was to be granted some of the Interim Legislative funding to hire a contractor in support of that effort for Nevada, perhaps one that has done similar work in Washington or another state that has gone through this process. Mr. Dick opined it is probable that this process would not be able to be completed by the start of the next Legislative Session, and explained the initial ask is to be provided block grant funding for the additional five dollars per capita, allowing for much needed support during the Foundational Capabilities process. When the results are determined, those findings would be brought back to the Legislature to be acted on in the following session.

Dr. Hess opined that the next Strategic Planning Retreat would be a good forum to educate the DBOH on this topic. Mr. Dick agreed that to be a good plan, and that he could present the slide deck Dr. Iser used in his presentation to the Interim Committee at that time.

Vice Chair Novak stated that he had just attended the NALBOH Board Meeting in Atlanta during the past week and informed of the three states that are required by their State Health Departments to be accredited by 2020.

## **12. \*Board Comment**

**Since there was no one wishing to speak, Vice Chair Novak closed the Board comment period.**

## **13. \*Public Comment**

Ms. Rebecca Anderson introduced herself as Director of Education for Alliance for Climate Education (ACE), and stated that she wished to thank the District Board of Health and expressed that the Air Quality Management Division has been a great partner of ACE for the past five years.

Vice Chair Novak opined that this is a great program and even more beneficial due to its accessibility to all who wish to use it. She informed that they are partnering with Washoe County School District to make sure it is used in their middle and high school classrooms.

Ms. Anderson thanked the Board for their partnership and provided her email address and their website, listed below:

[reb@acespace.org](mailto:reb@acespace.org)

<https://ourclimateourfuture.org/>

Ms. Brandhorst spoke of her concerns with housing in the community.

**Vice Chair Novak closed the public comment period**

## **15. Adjournment**

**Vice Chair Novak adjourned the meeting at 2:33 p.m.**

---

**Possible Changes to Agenda Order and Timing:** Items on the agenda may be taken out of order, combined with other items, withdrawn from the agenda, moved to the agenda of another later meeting; moved to or from the Consent section, or they may be voted on in a block. Items with a specific time designation will not be heard prior to the stated time, but may be heard later. Items listed in the Consent section of the agenda are voted on as a block and will not be read or considered separately unless withdrawn from the Consent agenda.

**Special Accommodations:** The District Board of Health Meetings are accessible to the disabled. Disabled members of the public who require special accommodations or assistance at the meeting are requested to notify Administrative Health Services in writing at the Washoe County Health District, PO Box 1130, Reno, NV 89520-0027, or by calling 775.328.2416, 24 hours prior to the meeting.

**Public Comment:** During the “Public Comment” items, anyone may speak pertaining to any matter either on or off the agenda, to include items to be heard on consent. For the remainder of the agenda, public comment will only be heard during items that are not marked with an asterisk (\*). Any public comment for hearing items will be heard before action is taken on the item and must be about the specific item being considered by the Board. In order to speak during any public comment, each speaker must fill out a “Request to Speak” form and/or submit comments for the record to the Recording Secretary. Public comment and presentations for individual agenda items are limited as follows: fifteen minutes each for staff and applicant presentations, five minutes for a speaker representing a group, and three minutes for individual speakers unless extended by questions from the Board or by action of the Chair.

**Response to Public Comment:** The Board of Health can deliberate or take action only if a matter has been listed on an agenda properly posted prior to the meeting. During the public comment period, speakers may address matters listed or not listed on the published agenda. The *Open Meeting Law* does not expressly prohibit responses to public comments by the Board of Health. However, responses from the Board members to unlisted public comment topics could become deliberation on a matter without notice to the public. On the advice of legal counsel and to ensure the public has notice of all matters the Board of Health will consider, Board members may choose not to respond to public comments, except to correct factual inaccuracies, ask for Health District Staff action or to ask that a matter be listed on a future agenda. The Board of Health may do this either during the public comment item or during the following item: “Board Comments – Limited to Announcement or Issues for future Agendas.”

**Posting of Agenda; Location of Website:**

Pursuant to NRS 241.020, Notice of this meeting was posted at the following locations:

Washoe County Health District, 1001 E. 9th St., Reno, NV  
Reno City Hall, 1 E. 1st St., Reno, NV  
Sparks City Hall, 431 Prater Way, Sparks, NV  
Washoe County Administration Building, 1001 E. 9th St, Reno, NV  
Downtown Reno Library, 301 S. Center St., Reno, NV  
Washoe County Health District Website [www.washoecounty.us/health](http://www.washoecounty.us/health)  
State of Nevada Website: <https://notice.nv.gov>

**How to Get Copies of Agenda and Support Materials:** Supporting materials are available to the public at the Washoe County Health District located at 1001 E. 9<sup>th</sup> Street, in Reno, Nevada. Ms. Laura Rogers, Administrative Secretary to the District Board of Health is the person designated by the Washoe County District Board of Health to respond to requests for supporting materials. Ms. Rogers is located at the Washoe County Health District and may be reached by telephone at (775) 328-2415 or by email at [lrogers@washoecounty.us](mailto:lrogers@washoecounty.us). Supporting materials are also available at the Washoe County Health District Website [www.washoecounty.us/health](http://www.washoecounty.us/health) pursuant to the requirements of NRS 241.020.

DD_	AH_
DHO	KD
DA	
Risk	

**Staff Report**  
**Board Meeting Date: May 24, 2018**

**TO:** District Board of Health

**FROM:** Nancy Kerns Cummins, Fiscal Compliance Officer  
775-328-2419, nkcummins@washoecounty.us

**SUBJECT:** Approve Subgrant Amendment #2 from the Nevada Department of Health and Human Services, Division of Public and Behavioral Health effective July 1, 2018 through June 30, 2019 in the amount of \$284,986.00 (no required match) in support of the Community and Clinical Health Services Division (CCHS) Immunization Program Internal Orders #10029 and #11319 and authorize the District Health Officer to execute the Subgrant Amendment.

---

**SUMMARY**

The Washoe County District Board of Health must approve and execute Interlocal Agreements. The District Health Officer is authorized to execute other agreements on the Board of Health's behalf not to exceed a cumulative amount of \$50,000 per contractor; over \$50,000 up to \$100,000 would require the approval of the Chair or the Board designee.

The Community and Clinical Health Services Division received Subgrant Amendment #2 from the State of Nevada Department of Health and Human Services, Division of Public & Behavioral Health on May 8, 2018 to support the Immunization Program for the next fiscal year. A copy of the Notice of Subgrant Amendment is attached.

**District Health Strategic Priority supported by this item:** Improve the health of our community by empowering individuals to live healthier lives.

**PREVIOUS ACTION**

There has been no previous action taken by the Board this fiscal year.

**BACKGROUND/GRANT AWARD SUMMARY**

**Project/Program Name:** Immunization Program

**Scope of the Project:** The Subgrant scope of work includes the following: conduct Vaccine for Children (VFC) compliance visits, perform Assessment, Feedback, Incentives and Exchanges (AFIX) assessments, perinatal Hepatitis B prevention activities, and seasonal influenza vaccination activities. The Subgrant provides funding for personnel, travel and training, operating expenses, professional services and indirect expenditures.

**Benefit to Washoe County Residents:** This Award supports the Immunization program mission to public health by reducing vaccine-preventable disease through immunization, with an emphasis on collaboration and cooperation with community partners.

**On-Going Program Support:** The Health District anticipates receiving continuous funding to support the IZ Program.

**Award Amount:** \$284,986.00  
**Grant Period:** July 1, 2018 through June 30, 2019  
**Funding Source:** Centers for Disease Control and Prevention (CDC)  
**Pass Through Entity:** State of Nevada, Department of Health and Human Services  
Division of Public & Behavioral Health  
**CFDA Number:** 93.268 & 93.539  
**Grant ID Number:** HD #15959 / NH23IP000727-05-00  
**Match Amount and Type:** No match required  
**Sub-Awards and Contracts:** No Sub-Awards are anticipated.

### **FISCAL IMPACT**

There is no additional fiscal impact should the Board approve Subgrant Amendment #2 as the FY19 budget in Internal Orders #10029 and #11319 was adopted with sufficient expenditure authority, no budget amendment is necessary.

### **RECOMMENDATION**

It is recommended that the Washoe County District Board of Health approve Subgrant Amendment #2 from the Nevada Department of Health and Human Services, Division of Public and Behavioral Health effective July 1, 2018 through June 30, 2019 in the amount of \$284,986.00 (no required match) in support of the Community and Clinical Health Services Division (CCHS) Immunization Program Internal Orders #10029 and #11319 and authorize the District Health Officer to execute the Subgrant Amendment.

### **POSSIBLE MOTION**

Should the Board agree with staff's recommendation, a possible motion would be: "Move to approve Subgrant Amendment #2 from the Nevada Department of Health and Human Services, Division of Public and Behavioral Health effective July 1, 2018 through June 30, 2019 in the amount of \$284,986.00 (no required match) in support of the Community and Clinical Health Services Division (CCHS) Immunization Program Internal Orders #10029 and #11319 and authorize the District Health Officer to execute the Subgrant Amendment."



State of Nevada  
 Department of Health and Human Services  
**Division of Public & Behavioral Health**

Original HD #: **15959**  
 Budget \_\_\_\_\_  
 Account: 3213  
 Category: 20  
 GL: 8516  
 Job Number: 9326817/9353917M

## SUBGRANT AMENDMENT #2

<b>Program Name:</b> Nevada State Immunization Program Bureau of Child, Family & Community Wellness	<b>Subgrantee Name:</b> Washoe County Health District (WCHD)
<b>Address:</b> 4150 Technology Way, Suite #210 Carson City, NV 89706-2009	<b>Address:</b> PO Box 11130 Reno, NV 89520
<b>Subgrant Period:</b> 04/01/17 through 06/30/19	<b>Amendment Effective Date:</b> Upon approval by all parties.

**This amendment reflects a change to:**

- Scope of Work
  Term
 Budget

**Reason for Amendment:** The Center for Disease Control and Prevention granted a 12 month extension on this award. This amendment extends the budget period and adds funds and Scope of Work changes for the 12-month extension period.

**Required Changes:**

**Current Language:** Subgrant Period: 04/01/17 through 06/30/18. The total reimbursement will not exceed \$356,302.00 during the subgrant period. See Section B and C of the original subgrant and Exhibit A of amendment #1.

**Amended Language:** Subgrant Period: 04/01/17 through **06/30/19**. The total reimbursement will not exceed **\$641,218.00** during the subgrant period. See the attached Section B and C **revised on 3/14/18** plus Exhibits A, B and **C** to Section C.

Budget Categories	Current Budget	Amended Adjustments	Revised Budget
1. Personnel	\$ 305,302.00	\$ 244,526.00	\$ 549,828.00
2. Travel	\$ 2,042.00	\$ 1,145.00	\$ 3,187.00
3. Operating	\$ 1,751.00	\$ 1,380.00	\$ 3,131.00
4. Equipment	\$ 0.00	\$ 0.00	\$ 0.00
5. Contractual/Consultant	\$ 0.00	\$ 0.00	\$ 0.00
6. Other	\$ 6,154.00	\$ 5,150.00	\$ 11,304.00
7. Indirect	\$ 40,983.00	\$ 32,785.00	\$ 73,768.00
<b>Total</b>	<b>\$ 356,232.00</b>	<b>\$ 284,986.00</b>	<b>\$ 641,218.00</b>

**Incorporated Documents:**

- Section B: Description of Services, Scope of Work and Deliverables **revised on 03/14/18**
- Section C: Budget and Financial Reporting Requirements **revised on 03/14/18**
- Exhibit A: Original Notice of Subgrant Award and all previous amendments

**By signing this Amendment, the Authorized Subgrantee Official or their designee, Program Manager, Bureau Chief, and Division of Public and Behavioral Health Administrator acknowledge the above as the new standard of practice for the above referenced Subgrant. Further, the undersigned understand this amendment does not alter, in any substantial way, the non-referenced contents of the Original Subgrant Award and all of its Attachments.**

Kevin Dick District Health Officer	Signature	Date
Beth Handler, MPH Bureau Chief, CFCW		
for Julie Kotchevar, PhD. Administrator, Division of Public & Behavioral Health		

**DIVISION OF PUBLIC AND BEHAVIORAL HEALTH  
NOTICE OF SUBGRANT AWARD**

**SECTION B**

**Description of Services, Scope of Work and Deliverables**

The intent of this subgrant is to perform activities deemed effective in improving immunization coverage and to reduce vaccine preventable disease among children, adolescents, and adults in Washoe County. The activities addressed in this Scope of Work are required under the federal Immunizations and Vaccine for Children Grant, CFDA 93.268, administered by the Centers for Disease Control and Prevention (CDC), and identified within the Immunization Program Operations Manual (IPOM) dated 2018.

Washoe County Health District (WCHD), hereinafter referred to as Subgrantee, agrees to provide the following services and reports according to the identified timeframes:

**Scope of Work for WCHD (July 1, 2018 – June 30, 2019)**

**CHAPTER A – PROGRAM STEWARDSHIP AND ACCOUNTABILITY**

**VFC COMPLIANCE VISITS**

Vaccines for Children (VFC) compliance visits ensure federally supplied vaccine is stored, handled, and administered appropriately. **All county Quality Assurance Coordinators are required to work closely with the state Provider Quality Assurance Manager.**

**Goal 1:** Enhance stewardship and accountability for all publicly purchased vaccine and VFC and Section 317 funding.

<b><u>Objective</u></b>	<b><u>Activities</u></b>	<b><u>Due Date</u></b>	<b><u>Documentation Needed</u></b>
-------------------------	--------------------------	------------------------	------------------------------------

**DIVISION OF PUBLIC AND BEHAVIORAL HEALTH  
NOTICE OF SUBGRANT AWARD**

<p>1. (IPOM A-6) By 6/30/2019, assure VFC-enrolled providers comply with VFC Program requirements through annual compliance visits to <u>at least 50%</u> of active enrolled providers in jurisdiction and other means as defined in the VFC Operations Guide.</p>	<p>1) From July 1, 2018 – June 30, 2019, state Provider Quality Assurance Manager and county coordinators are responsible for conducting compliance visits on a minimum of 50% of enrolled VFC providers. State and county coordinators are responsible for the providers in their specific jurisdiction. Every month, state and county coordinators are responsible for conducting a minimum designated amount of VFC compliance visits. This schedule helps coordinators meet the annual goal of 50%. The following are required for VFC Compliance Visits:</p> <ul style="list-style-type: none"> <li>a) Utilize the most current VFC Compliance Visit Reviewer Guide as provided in PEAR. <b>Submit VFC Compliance Visit data in PEAR while in the provider’s office or on the same day of the visit. Beginning January 2018, all Compliance Visits must be accomplished in PEAR while in the provider’s office.</b></li> <li>b) Conduct VFC Compliance Visits on 100% of newly enrolled VFC providers no sooner than 90 days and no later than 120 days after enrollment.</li> <li>c) Provide technical assistance and/or follow-up visits as directed by the NSIP Provider Quality Assurance Manager or Vaccine Manager.</li> <li>d) Washoe County QA Coordinators will complete the VFC Program requirements training annually, as is required for VFC providers and staff.</li> <li>e) Generate, send, and document completion and dissemination of the 6-month communication letter in PEAR.</li> </ul> <p>2) As assigned by the NSIP Vaccine Manager,</p>	<p>6/30/2019</p>	<ul style="list-style-type: none"> <li>1. Mid-Year and End-of-Year Progress Report (templates will be sent by NSIP and a due date provided).</li> <li>2. As soon as possible after the VFC Compliance Visit, submit to NSIP the following documentation for visits completed: <ul style="list-style-type: none"> <li>a. Acknowledgement of Receipt signed by the signing Provider/Medical Director or delegate.</li> <li>b. VFC Program annual training documentation when applicable.</li> </ul> </li> <li>3. Submit Compliance Visit data and unannounced visit data into the PEAR Online Tool <b>while in the provider’s office or on the same day of the visit. Beginning January 2018, all Compliance Visits must be accomplished in PEAR while in the provider’s office.</b></li> <li>4. Enter follow-up provider contacts in PEAR until 100% compliance is achieved.</li> <li>5. Submit Reviewer Follow-Up Plan in PEAR when non-compliance issues are resolved.</li> <li>6. As soon as possible after the</li> </ul>
--	---	------------------	--



**DIVISION OF PUBLIC AND BEHAVIORAL HEALTH  
NOTICE OF SUBGRANT AWARD**

	<p>perform Unannounced Storage and Handling Visits on identified VFC Providers in jurisdiction.</p> <p>3) Ensure every VFC Vaccine Coordinator and Backup completes the mandatory annual VFC training as required by CDC:</p> <ul style="list-style-type: none"> <li>a) Attendance at a VFC Compliance Visit, <b>OR</b></li> <li>b) Certificates of completion from the “You Call the Shots” modules 10 &amp; 16, <b>OR</b></li> <li>c) QA Coordinator training session utilizing the VFC Training Elements Checklist in-person or by phone.</li> </ul> <p>4) Update VFC Provider and staff contact information in PEAR and AFIX Online Tools as changes occur in VFC Provider offices within WCHD’s jurisdiction (e.g., changes in Primary or Back-Up Vaccine Coordinators).</p> <p>5) Relocate short-dated publicly-funded vaccine as requested by NSIP staff to prevent vaccine waste.</p> <p>6) Complete the monthly accomplishment log and submit to the Provider Quality Assurance Manager.</p>		<p>Unannounced Storage &amp; Handling Visit, submit to NSIP the following documentation for visits completed:</p> <ul style="list-style-type: none"> <li>a. Acknowledgement of Receipt signed by the signing Provider/Medical Director or delegate.</li> <li>b. Complete, send, and document completion of the 6-month communication letter.</li> </ul> <p>7. Deliver VFC Providers’ annual VFC training data to the NSIP Provider Quality Assurance Manager to assist with tracking VFC provider compliance statewide.</p>
--	---	--	---

**CHAPTER B – ASSESSING PROGRAM PERFORMANCE**

**AFIX ASSESSMENTS**

AFIX (Assessment, Feedback, Incentives and eXchange) is a continuous quality improvement process used to improve provider practices and raise immunization coverage rates. **All county Quality Assurance Coordinators are required to work closely with the state Provider Quality Assurance Manager.**

**Goal 2:** Assess program performance for program improvement.

<u>Objective</u>	<u>Activities</u>	<u>Due Date</u>	<u>Documentation Needed</u>
------------------	-------------------	-----------------	-----------------------------

**DIVISION OF PUBLIC AND BEHAVIORAL HEALTH  
NOTICE OF SUBGRANT AWARD**

<p>1. (IPOM B-3) By 6/30/2019, work with VFC Providers on quality improvement processes to increase coverage levels and decrease missed opportunities using AFIX components, as appropriate, and move toward use of NV WebIZ as the primary source of data for provider coverage level assessments.</p>	<p>1) From July 1, 2018 – June 30, 2019, state Provider Quality Assurance Manager and county coordinators will conduct childhood AFIX assessments on selected VFC Providers. The following are required with each AFIX Visit:</p> <ul style="list-style-type: none"> <li>a) Utilize NV WebIZ to conduct AFIX assessments.</li> <li>b) Complete the Assessment Questionnaire and assist the provider to select 2 areas of Quality Improvement. Create a Quality Improvement Action Plan for each provider.</li> <li>c) After receiving the updated immunization information from the provider, generate from NV WebIZ the 4.3.1.3.3.1.4 series rate and the adolescent rates the day before the feedback visit.</li> <li>d) Utilizing the AFIX Online Tool, enter the correct provider information, general AFIX Visit information, Assessment Questionnaire, assessment results, feedback, and all follow-up. Utilize the NV WebIZ-generated file to upload data results into AFIX Online.</li> <li>e) Conduct a follow-up session within 6 months of the feedback session to include an assessment on the same age cohort, <b>but not the same patients</b>.</li> <li>f) Follow provider’s progress to 100% implementation of selected Quality Improvement Activities.</li> <li>g) Attach Report Cards and the Quality Improvement Action Plan to the “File” section of AFIX Online.</li> <li>h) Providers with childhood rates less than 75% will receive a third assessment.</li> <li>i) Promote reminder/recall programs, NV WebIZ classes, and NILE education activities during provider visits.</li> </ul>	<p>6/30/19</p>	<ul style="list-style-type: none"> <li>1. Mid-Year and End-of-Year Progress Report (templates will be sent by NSIP and a due date provided).</li> <li>2. Within 30 days of the AFIX Visit, submit the following documentation: <ul style="list-style-type: none"> <li>a. Childhood/Adolescent Immunization Report Cards</li> </ul> </li> <li>3. Enter the AFIX Visit data into the AFIX Online Tool within 5 days of completing the visit.</li> <li>4. Document progress on Quality Improvement Activities in the AFIX Online Tool during each follow-up visit.</li> </ul>
---	--	----------------	--

**DIVISION OF PUBLIC AND BEHAVIORAL HEALTH  
NOTICE OF SUBGRANT AWARD**

	<p>j) Perform immunization assessments for all NV WebIZ users in jurisdiction for the annual Silver Syringe Awards. Generate immunization rates in NV WebIZ for those providers who did not receive an AFIX visit.</p> <p>2) From October 1, 2018 – June 30, 2019, conduct AFIX assessments on at least 3 VFC Providers in jurisdiction who immunized 10 or more adolescents. WCHD will conduct adolescent AFIX Visits evaluating 13-17-year-olds for:</p> <ul style="list-style-type: none"><li>Up-to-Date (UTD) HepB</li><li>2 MMR</li><li>2 VAR</li><li>1 Tdap</li><li>UTD MCV4</li><li>1 HPV</li><li>UTD HPV</li><li>1 Flu</li><li>2 HepA</li><li>UTD Polio</li></ul> <p>Rates and reports will be generated in and exported from NV WebIZ into the AFIX Online Tool.</p>		
--	---	--	--

**CHAPTER C – ASSESSING ACCESS TO VACCINATIONS**

**PERINATAL HEPATITIS B PREVENTION**

Based on the success of past endeavors of Hepatitis B disease reduction among both children and adults, the CDC seeks to eliminate Hepatitis B virus transmission in the United States. This goal cannot be achieved without assistance from the immunization awardees, especially the Perinatal Hepatitis B Prevention coordinators. **All county Perinatal Hepatitis B Coordinators are required to work closely with the state Perinatal Hepatitis B Coordinator.**

**All jurisdictions are required to use the Perinatal Hepatitis B Module within NV WebIZ to conduct case management activities for all infants born to HBsAg positive mothers. Case, infant, and contact information including serology, HBIG, and hepatitis B vaccination dates must be documented in this module.**

**The annual Perinatal Hepatitis B Prevention Assessment is due to the state Coordinator upon request.**

**Goal 3:** Work with partners, as appropriate, to assure coordination of the following activities to prevent perinatal Hepatitis B transmission.

<b><u>Objective</u></b>	<b><u>Activities</u></b>	<b><u>Due Date</u></b>	<b><u>Documentation Needed</u></b>
1. (IPOM C5-a) From July 1, 2018 – June 30, 2019, identify HBsAg-positive pregnant women in jurisdiction.	1) From July 1, 2018 – June 30, 2019, educate prenatal, postpartum, and pediatric providers on the importance of screening all women during every pregnancy for HBsAg.  2) From July 1, 2018 – June 30, 2019, improve mechanisms to identify women who are HBsAg-positive and pregnant.  3) From July 1, 2018 – June 30, 2019, identify household and sexual contacts. Offer testing and Hepatitis B vaccination.	6/30/2019	1. Mid-Year and End-of-Year Progress Report (templates will be sent by NSIP and a due date provided).

**DIVISION OF PUBLIC AND BEHAVIORAL HEALTH  
NOTICE OF SUBGRANT AWARD**

<p>2. (IPOM C5-b) From July 1, 2018 – June 30, 2019, prophylax newborns with Hepatitis B vaccine and HBIG.</p>	<p>1) From July 1, 2018 – June 30, 2019, provide technical assistance to each birthing hospital in jurisdiction to establish mechanisms to confirm women’s HBsAg status at time of delivery, and if a woman presents for delivery without documentation or HBsAg status is unknown, establish policies or mechanisms to immediately test for HBsAg status.</p>	<p>6/30/2019</p>	<p>1. Mid-Year and End-of-Year Progress Report (templates will be sent by NSIP and a due date provided).</p>
--	--	------------------	--

**DIVISION OF PUBLIC AND BEHAVIORAL HEALTH  
NOTICE OF SUBGRANT AWARD**

	<p>2) From July 1, 2018 – June 30, 2019, if mother is HBsAg-positive, establish policies or mechanisms to administer Hepatitis B vaccine and HBIG to infant within 12 hours of birth. If HBsAg status is unknown at birth, then administer Hepatitis B vaccine to infant within 12 hours of birth. Provide technical assistance to each birthing hospital in jurisdiction to establish policies or mechanisms to administer HBIG to infant as soon as HBsAg-positive status is confirmed, but no later than one week after birth.</p> <p>3) From July 1, 2018 – June 30,2019, review mechanisms for birthing hospitals to routinely provide documentation of date and time of HBIG and Hepatitis B vaccine administration to exposed newborn to the infant’s identified health care provider and the county Perinatal Hepatitis B Prevention Program.</p> <p>4) From July 1, 2018 – June 30,2019, review policies and mechanisms to have birthing hospitals routinely provide documentation of date/time and type of post-exposure prophylaxis administered to infants born to women with unknown HBsAg status to the newborn’s pediatrician and the county Perinatal Hepatitis B Prevention Program and to provide results of HBsAg screening as soon as results become available.</p> <p>5) From July 1, 2018 – June 30,2019, provide technical assistance to each birthing hospital in jurisdiction to develop policies and/or procedures for administering the first dose of Hepatitis B vaccine to all infants born to HBsAg-negative women before hospital discharge or, for infants weighing less than 2,000 grams, at one month or hospital discharge, whichever comes first.</p>		
--	---	--	--

**DIVISION OF PUBLIC AND BEHAVIORAL HEALTH  
NOTICE OF SUBGRANT AWARD**

<p>3. (IPOM C-5c) From July 1, 2018 – June 30, 2019, increase timely completion of HepB doses 2 and 3 for identified infants.</p>	<ol style="list-style-type: none"> <li>1) From July 1, 2018 – June 30, 2019, review and improve mechanisms and implement remind/recall of infants enrolled in the Perinatal Hepatitis B Prevention Program so that they receive all required vaccine doses of the hepatitis B vaccine series on schedule.</li> <li>2) From July 1, 2018 – June 30, 2019, review and improve protocols to actively follow up with families that do not receive the full hepatitis B vaccine series according to the most current ACIP-recommended childhood immunization schedule.</li> <li>3) From July 1, 2018 – June 30, 2019, review and improve mechanisms to ensure that the Perinatal Hepatitis B Prevention Program receives documentation of administration data (mm/dd/yyyy) for all Hepatitis B vaccine doses administered to the identified infants born to HBsAg-positive women.</li> </ol>	<p>6/30/2019</p>	<p>1. Mid-Year and End-of-Year Progress Report (templates will be sent by NSIP and a due date provided).</p>
<p>4. (IPOM C-5d) From July 1, 2018 – June 30, 2019, increase post-vaccination serology.</p>	<ol style="list-style-type: none"> <li>1) From July 1, 2018 – June 30, 2019, identify contributing factors that prevent infants from obtaining post-vaccination serologic testing (PVST) within the ACIP-recommended time frame.</li> <li>2) From July 1, 2018 – June 30, 2019, develop and implement an action plan to reduce/eliminate identified factors within program’s control that prevent infants from obtaining timely PVST. Provide a copy of the plan to State Perinatal Hepatitis B Coordinator upon completion.</li> <li>3) From July 1, 2018 – June 30, 2019, identify, contact, and collaborate with other entities that may be able to reduce or eliminate identified factors outside program control that prevent infants from obtaining timely and appropriate PVST.</li> </ol>	<p>6/30/2019</p>	<p>1. Mid-Year and End-of-Year Progress Report (templates will be sent by NSIP and a due date provided).</p> <p>2. Copy of Action Plan.</p>

**DIVISION OF PUBLIC AND BEHAVIORAL HEALTH  
NOTICE OF SUBGRANT AWARD**

	<p>4) From July 1, 2018 – June 30, 2019, develop and implement mechanisms that remind/recall infants enrolled in the Perinatal Hepatitis B Prevention Program to receive PVST when due.</p> <p>5) From July 1, 2018 – June 30, 2019, review and improve protocols that actively follow up with families of infants that do not obtain PVST according to the ACIP recommendations.</p> <p>6) From July 1, 2018 – June 30, 2019, review and improve protocols to close infants to Perinatal Hepatitis B Prevention Program services with PVST results that report the infants are protected against hepatitis B infection.</p> <p>7) From July 1, 2018 – June 30, 2019, review and improve protocols to actively follow-up with families of infants with PVST results that indicate infants remain susceptible to hepatitis B infection to revaccinate infant with 2<sup>nd</sup> hepatitis B vaccine series and receive PVST after the completion of the 2<sup>nd</sup> hepatitis B vaccine series.</p> <p>8) From July 1, 2018 – June 30, 2019, review and improve mechanisms to obtain and document date of infant’s PVST and results from appropriate sources (i.e., family, lab, health care provider, etc.).</p>		
--	--	--	--

**CHAPTER E – IMPROVE AND MAINTAIN PREPAREDNESS**

**SEASONAL INFLUENZA VACCINATION**

**Goal 4:** Conduct seasonal influenza vaccination activities to improve preparedness for an influenza pandemic.

<b><u>Objective</u></b>	<b><u>Activities</u></b>	<b><u>Due Date</u></b>	<b><u>Documentation Needed</u></b>
1. (IPOM E-3)	1) Work with Immunize Nevada and other local	6/30/2019	1. Mid-Year and End-of-Year



**DIVISION OF PUBLIC AND BEHAVIORAL HEALTH  
NOTICE OF SUBGRANT AWARD**

<p>From July 1, 2018 – June 30, 2019, work with new and existing partners to increase demand for seasonal influenza vaccine to improve preparedness for an influenza pandemic.</p>	<p>partners, especially those which serve groups at high risk for complications from influenza and/or underserved populations, to increase demand for seasonal influenza vaccination.</p> <p>2) Conduct outreach seasonal influenza vaccination clinics for targeted populations.</p> <p>3) Conduct immunization trainings for new and existing partners to increase demand for seasonal influenza vaccine and other recommended immunizations across the lifespan.</p>	<p>Progress Report (templates will be sent by NSIP and a due date provided).</p> <p>2. Outreach Vaccination Clinic Reports including, when feasible, # of clinics held, total # of individuals targeted, dates/locations of clinics, and a description of the target population by age and race/ethnicity.</p> <p>3. Immunization Trainings Reports including location, # of participants, and description of target audience.</p>
--	---	--

**DIVISION OF PUBLIC AND BEHAVIORAL HEALTH  
NOTICE OF SUBGRANT AWARD**

**SECTION C**

**Budget and Financial Reporting Requirements  
Revised on 03/14/18**

Identify the source of funding on all printed documents purchased or produced within the scope of this subgrant, using a statement similar to: "This publication (journal, article, etc.) was supported by the Nevada State Division of Public and Behavioral Health through Grant Number NH23IP00727 from The Centers for Disease Control and Prevention (CDC). Its contents are solely the responsibility of the authors and do not necessarily represent the official views of neither the Division nor the CDC."

Any activities performed under this subgrant shall acknowledge the funding was provided through the Division by Grant Number NH23IP00727 from The Centers for Disease Control and Prevention (CDC).

Subgrantee agrees to adhere to the following budget:

<u>Category</u>	<u>Total cost</u>	<u>Detailed cost</u>	<u>Details of expected expenses</u>
1. Personnel	\$ 244,526.00	<b>See Exhibit A, B and C to Section C</b>	
		\$	
2. Travel	\$ 1,145.00		
		\$	
3. Operating	\$ 1,380.00		
		\$	
4. Equipment	\$		
		\$	
5. Contractual Consultant	\$		
		\$	
6. Other	\$ 5,150.00		
		\$	
7. Indirect	\$ 32,785.00		
		\$	
<b>Total Cost</b>	<b>\$ 284,986.00</b>		

- Categorical adjustments of 10% or less are permitted and must be requested and approved through the Nevada State Immunization Program Manager. Written permission must be obtained and can be done via e-mail.
- Equipment purchased with these funds belongs to the federal program from which this funding was appropriated and shall be returned to the program upon termination of this agreement.
- Travel expenses, per diem, and other related expenses must conform to the procedures and rates allowed for State officers and employees. It is the Policy of the Board of Examiners to restrict contractors/Subgrantees to the same rates and procedures allowed State Employees. The State of Nevada reimburses at rates comparable to the rates established by the US General Services Administration, with some exceptions (State Administrative Manual 0200.0 and 0320.0).

**Subgrantee agrees to request reimbursement according to the schedule specified below for the actual expenses incurred related to the Scope of Work during the subgrant period.**

- Nevada State Immunization Program must receive Requests for Reimbursement no later than the fifteenth (15<sup>th</sup>) day of each month for the prior month's actual expenses;
- The maximum available through this subgrant is \$641,218.00.

**DIVISION OF PUBLIC AND BEHAVIORAL HEALTH  
NOTICE OF SUBGRANT AWARD**

- Requests for Reimbursement will be accompanied by supporting documentation, including a line item description of expenses incurred;
- Reimbursements will not be processed without all **mandatory reporting documents**:
  - Request for Reimbursement Form
  - Reimbursement Worksheet
  - Receipts for supplies, travel, equipment, and other items purchased.
- Reimbursement is based on actual expenditures incurred during the period being reported. The Reimbursement Worksheet supplied should be used to tabulate and summarize the expenses by grant category and should be submitted with the other documents as described below;
  - Submit one hard copy via postal mail of original, signed Request for Reimbursement, Reimbursement Worksheet, and copies of receipts;
- Additional expenditure detail will be provided upon request from the Division.

**Additionally, the Subgrantee agrees to provide:**

- A complete financial accounting of all expenditures to the Division within 30 days of the CLOSE OF THE SUBGRANT PERIOD. Any un-obligated funds shall be returned to the Division at that time, or if not already requested, shall be deducted from the final award.

**The Division agrees:**

- To provide technical assistance to subgrantee, upon request;
- Reimburse subgrantees for Scope of Work accomplished per subgrant upon proper documentation from subgrantee;
- Submit reimbursement request to the Division of Public and Behavioral Health Fiscal Services within five (5) business days but only upon receipt of all mandatory reporting documents; and
- The Division reserves the right to hold reimbursement under this subgrant until any delinquent forms, reports, and expenditure documentation are submitted to and accepted by the Division.

**Both parties agree:**

The Subgrantee will, in the performance of the Scope of Work specified in this subgrant, perform functions and/or activities that could involve confidential information; therefore, the Subgrantee is requested to fill out and sign Section F, which is specific to this subgrant, and will be in effect for the term of this subgrant.

All reports of expenditures and requests for reimbursement processed by the Division are SUBJECT TO AUDIT.

This subgrant agreement may be TERMINATED by either party prior to the date set forth on the Notice of Subgrant Award, provided the termination shall not be effective until 30 days after a party has served written notice upon the other party. This agreement may be terminated by mutual consent of both parties or unilaterally by either party without cause. The parties expressly agree that this Agreement shall be terminated immediately if for any reason the Division, state, and/or federal funding ability to satisfy this Agreement is withdrawn, limited, or impaired.

**Financial Reporting Requirements**

- A Request for Reimbursement is due on a monthly or quarterly basis, based on the terms of the subgrant agreement, no later than the 15<sup>th</sup> of the month.
- Reimbursement is based on actual expenditures incurred during the period being reported.
- Payment will not be processed without all reporting being current.
- Reimbursement may only be claimed for expenditures approved within the Notice of Subgrant Award.

## Washoe County Health District - April 1, 2017 - June 30, 2018 Budget

VFC OPS - NOT TO EXCEED \$204,433						PPHF - NOT TO EXCEED \$167,417					
Personnel:	Salary*	FTE	Total	Personnel:	FTE	Salary*	Total				
VFC / AFIX Coord #1	160,290	77%	\$ 123,423	VFC / AFIX Coord #2	38%	160,328	\$ 60,925				
PHN #1	119,000	40%	\$ 47,600	PHN #2	50%	160,349	\$ 80,174				
				Peri Hep-B Coord	5%	141,170	\$ 7,059				
*Total salary includes fringe				*Total salary includes fringe							
<b>Total Personnel:</b>			<b>\$ 171,023</b>	<b>Total Personnel:</b>			<b>\$ 148,157</b>				<b>\$ 319,180</b>
<b>Travel:</b>			<b>Total</b>	<b>Travel:</b>			<b>Total</b>				
NV statewide conf - reg	2 \$ 250.000		\$ 500								
" - airfare	2 \$ 250.000		\$ 500								
" - lodging	2 \$ 102.000	2	\$ 408								
" - per diem	2 \$ 69.000	2	\$ 276								
" - per diem	2 \$ 30.000	1	\$ 60								
" - airport parking	2 \$ 14.000	3	\$ 84								
" - ground transp	2 \$ 25.000	2	\$ 100								
staff local travel	211 \$ 0.54		\$ 114								
<b>Total Travel:</b>			<b>\$ 2,042</b>	<b>Total Travel:</b>			<b>\$ -</b>				<b>\$ 2,042</b>
<b>Operating:</b>			<b>Total</b>	<b>Operating:</b>			<b>Total</b>				
copier / copies	15 \$ 72		\$ 1,080								
telephone	15 \$ 41		\$ 615								
<b>Total Operating:</b>			<b>\$ 1,695</b>	<b>Total Operating:</b>			<b>\$ -</b>				<b>\$ 1,695</b>
<b>Equipment:</b>			<b>Total</b>	<b>Equipment:</b>			<b>Total</b>				
			\$ -				\$ -				\$ -
<b>Total Equipment:</b>			<b>\$ -</b>	<b>Total Equipment:</b>			<b>\$ -</b>				\$ -
<b>Contractual:</b>			<b>Total</b>	<b>Contractual:</b>			<b>Total</b>				\$ -
			\$ -				\$ -				\$ -
<b>Total Contractual:</b>			<b>\$ -</b>	<b>Total Contractual:</b>			<b>\$ -</b>				\$ -
<b>Other:</b>			<b>Total</b>	<b>Other:</b>			<b>Total</b>				\$ -
MD consultant	15 335		\$ 5,020								
Service agreement (alarm)	0.5 2268		\$ 1,134								
<b>Total Other:</b>			<b>\$ 6,154</b>	<b>Total Other:</b>			<b>\$ -</b>				<b>\$ 6,154</b>
Indirect	\$180,914	13%	\$ 23,519	Indirect	\$ 148,157	13%	\$ 19,260				
<b>Total Indirect:</b>			<b>\$ 23,519</b>	<b>Total Indirect:</b>			<b>\$ 19,260</b>				
<b>Total VFC Ops Budget:</b>			<b>\$ 204,433</b>	<b>Total PPHF Budget:</b>			<b>\$ 167,417</b>				<b>\$ 371,850</b>
			55%				45%				

**Staff Report**  
**Board Meeting Date: May 24, 2018**

**TO:** District Board of Health

**FROM:** Nancy Kerns Cummins, Fiscal Compliance Officer, Washoe County Health District  
775-328-2419, [nkcummins@washoecounty.us](mailto:nkcummins@washoecounty.us)

**SUBJECT:** Accept cash donation in the amount of \$5,000 from Arctica Ice Sales to purchase Long Acting Reversible Contraceptives (LARCs) to help decrease unintended pregnancy rates; approve amendments totaling an increase of \$5,000 in both revenue and expense to the FY18 Arctica Ice Donation budget, IO# 20424.

**SUMMARY**

Pursuant to Chapter 15 of Washoe County Code, specifically section 15.160, cash donations must be reported to the board and expenditure authorization obtained.

**District Health Strategic Objective supported by this item:**

**Healthy Lives:** Improve the health of our community by empowering individuals to live healthier lives.

**Financial Stability:** Enable the Health District to make long-term commitments in areas that will positively impact the community's health by growing reliable sources of income.

**PREVIOUS ACTION**

On February 23, 2017, the Board accepted a \$4,000 donation for Arctica Ice Sales to the Family Planning Program.

**BACKGROUND**

Washoe County Health District's Family Planning Program received a \$5,000 corporate donation on May 10, 2018 from Arctica Ice Sales to purchase Long Acting Reversible Contraceptives to help decrease unintended pregnancy rates.

**FISCAL IMPACT**

Should the board accept this cash donation, the adopted FY18 budget will be increased by \$5,000 in the following accounts:

<u>Account Number</u>	<u>Description</u>	<u>Amount of Increase/Decrease</u>
IO-20424 - 484000	Donations	\$5,000.00
IO-20424 - 710703	Biologicals	\$5,000.00

**RECOMMENDATION**

Staff recommends the District Board of Health accept cash donation in the amount of \$5,000 from Arctica Ice Sales to purchase Long Acting Reversible Contraceptives (LARCs) to help decrease high unintended pregnancy rates; approve amendments totaling an increase of \$5,000 in both revenue and expense to the FY18 Arctica Ice Donation budget, IO# 20424.

**POSSIBLE MOTION**

Should the Board agree with staff's recommendation, a possible motion would be: "Move to accept cash donation in the amount of \$5,000 from Arctica Ice Sales to purchase Long Acting Reversible Contraceptives (LARCs) to help decrease high unintended pregnancy rates; approve amendments totaling an increase of \$5,000 in both revenue and expense to the FY18 Arctica Ice Donation budget, IO# 20424."

DD	___	___
DHO	___	___
DA	___	___

**STAFF REPORT**  
**BOARD MEETING DATE:** May 24, 2018

**TO:** District Board of Health  
**THROUGH:** Kitty Jung, Chair  
District Board of Health  
**FROM:** Kevin Dick, District Health Officer  
775-326-2416, kdick@washoecounty.us  
**SUBJECT:** **Possible reappointment of Dr. Andrew Michelson, Emergency Room Physician, to the Regional Emergency Medical Services Advisory Board**

---

**SUMMARY**

The Interlocal Agreement (ILA) for Regional Emergency Medical Services (EMS) Oversight establishes a Regional EMS Advisory Board. The Regional EMS Advisory Board (EMSAB) includes two District Board of Health (DBOH) appointed positions, an Emergency Room Physician and a Hospital Continuous Quality Improvement Representative.

Dr. Andrew Michelson, the Emergency Room Physician member of the EMSAB, whose first term expired in October of 2107, has indicated that he would be willing to serve a second term. The DBOH must approve this reappointment.

**District Health Strategic Priority supported by this item:** *Extend our impact by leveraging partnerships to make meaningful progress on health issues*

**PREVIOUS ACTION**

On October 23, 2014, the Board appointed Dr. Andrew Michelson to fill the position of Emergency Room Physician on the Emergency Medical Services Advisory Board.

The ILA for Regional EMS Oversight has been approved by the governing bodies of Reno, Sparks, Truckee Meadows Fire Protection District, Washoe County, and the Washoe County Health District.

Article 2 of the ILA establishes a Regional EMS Advisory Board. The Board is composed of the following members

- a. City Manager, Reno
- b. City Manager, Sparks
- c. County Manager, Washoe County
- d. District Health Officer
- e. Emergency Room Physician (DBOH Appointment)
- f. Hospital Continuous Quality Improvement (CQI) Representative (DBOH Appointment)

## **BACKGROUND**

The ILA for Regional EMS Oversight was been approved by the governing bodies of Reno, Sparks, Truckee Meadows Fire Protection District, Washoe County, and the Washoe County Health District. Article 2 of the ILA establishes a Regional EMS Advisory Board. The Board is composed of the following members

- a. City Manager, Reno
- b. City Manager, Sparks
- c. County Manager, Washoe County
- d. District Health Officer
- e. Emergency Room Physician (DBOH Appointment)
- f. Hospital Continuous Quality Improvement (CQI) Representative (DBOH Appointment)

The Advisory Board will be responsible for electing a chair and vice-chair and for establishing bylaws. The Advisory Board must meet at least once each fiscal year to review reports, evaluations and/or recommendations of the Regional EMS Oversight Program, and discuss issues related to regional emergency medical services. The Advisory Board may make recommendations to the District Health Officer and/or DBOH.

The Board created bylaws, which became effective in March 2015 and were updated in October of 2016. Detailed within the bylaws are the terms for the DBOH appointed positions. The Emergency Room Physician appointment is for three (3) years, with an eligibility of reappointment for two additional two (2) year terms. The bylaws also state that upon the resignation or expiration of the DBOH appointee's term, the member shall continue to serve until his/her successor qualifies and is appointed. Dr. Michelson's original term expired in October of 2017 and he has continued to serve during that time. In April of 2018, he indicated his willingness and desire to remain on the Board for a second term. Dr. Michelson's CV is attached.

## **FISCAL IMPACT**

There is no additional fiscal impact to the FY18 budget anticipated from this item.

## **RECOMMENDATION**

Staff recommends the Board reappoint Dr. Andrew Michelson, Emergency Room Physician to the Regional Emergency Medical Services Advisory Board.

## **POSSIBLE MOTION**

If the Board agrees with staff's recommendation, a possible motion would be: "Move to reappoint Dr. Andrew Michelson, Emergency Room Physician to the Regional Emergency Medical Services Advisory Board."



Andrew C Michelson, MD  
4415 Starwood Ct.  
Reno, NV 89519  
(775) 250-0455  
emdoc@me.com

**Education:**

2008-'11                      Emergency Medicine Residency, UNSOM

2004-'08                      University of Nevada, School of Medicine  
-Degree: Medical Doctor

2003-'04                      University of Nevada, Reno - Post-Baccalaureate courses:  
-Immunology  
-Metabolic Regulation

1999-'03                      University of Colorado at Boulder  
-Degree: Bachelor of Science

**Licenses and Certifications:**

Oct. 2012	ABEM Oral Boards	passed
Nov. 2011	ABEM Written Boards	passed
July 2009	USMLE step 3	passed
Feb. 2008	USMLE step 2 CS	passed
July 2007	USMLE step 2 CK	passed
July 2006	USMLE step 1	passed
	ACLS, PALS	current

**Research:**

2010-'11                      “In the presentation of Acute Aortic Dissection in the  
Emergency Department, are there ECG changes suggestive  
of ischemia and if so could the ECG be used towards early  
recognition of dissection.” (UNSOM EMR project with Dr Slattery)

2010-'11                      Health Care Delivery project: Lumbar Puncture video  
consent – promotes efficiency and quality improvement of  
procedural consent in the ED.

2003-'04                      “Reactive radical interactions with clean and adsorbate  
covered semiconductor surfaces” (An NSF funded project of  
the Dept. of Chemistry at University of Nevada, Reno with mentor Dr.  
Casey - Involvement: Conducting High Resolution Transmission Electron  
Microscopy of the substance in study)

**Professional Activities:**

2014-present	UNSOM FP SMRMC ED Rotation Physician Coordinator
2013-present	UNSOM Medical Education Admissions Committee
2011-present	UNSOM EM Career Advisory Group Physician Leader
2010-2011	Paramedic School Lectures: -Head and Neck Emergencies -Cardiovascular Emergencies -Pulmonary Emergencies
2008-2011	Resident Lecture Series: -Prehospital Airway Management -"Red Herring" or Epidural Abscess -Viruses and Your Patients' Protection -Non-CNS Headaches and Their Management -Interesting case: Mesenteric Ischemia, NSTEMI, Sick Sinus -"To Line or Not to Line" Invasive Management of Sepsis
2008-present	American College of Emergency Physician – member
2008-present	American Academy of Emergency Medicine - member

**Employment/Volunteer:**

2011-present	Reno Emergency Physician Associates
2010-'11	UNSOM EM Residency – Chief Resident -Academic conference coordinator -Resident clinical scheduler -Applicant interview panel
2010-2011	Nellis Air Force Base Tactical Training and Paratrooper Education
2010-2011	NASCAR Resident Physician
2005	Child Family Health International - South Africa, Capetown
2004-'06	UNSOM Student Outreach Clinic
2002-'04	Saint Mary's Regional Medical Center -Reno, NV -Radiology Technician aide and Patient Transport

**STAFF REPORT**  
**BOARD MEETING DATE: May 24, 2018**

**TO:** District Board of Health  
**FROM:** James English, EHS Supervisor  
775-328-2610, jenglish@washoecounty.us  
**SUBJECT:** Recommendation to uphold the recommendation of the Sewage, Wastewater, and Sanitation Hearing Advisory Board with conditions for Variance #H18-0001VARI for APN 017-123-05, owned by Mike Fritz.

**SUMMARY**

The staff report summarizes the Environmental Health Services Division's (EHS) review of the variance request along with the recommendation from the Sewage, Wastewater, and Sanitation Hearing Advisory Board (SWS Board) for Variance #H18-0001VARI for APN 017-123-05 as heard on May 7, 2018.

**District Health Strategic Objective supported by this item:**

**Healthy Environment:** Create a healthier environment that allows people to safely enjoy everything Washoe County has to offer.

**PREVIOUS ACTION**

Environmental Health Services Staff (EHS) has worked with both the property owner and the engineer to find the best possible solution to design an onsite sewage disposal system for this property. The property is 1.004 acres and served by a community water system. The parcel has Bailey Creek running through it flowing from south to north when water is present. During the design phase to build on the property and place an onsite sewage disposal system, it was determined there was no way to meet the setbacks required in Section 040.080 of the Regulations of the Washoe County District Board of Health Governing Sewage, Wastewater, and Sanitation (SWS Regulations).

The property owner applied for a variance to Section 040.080 and Table 2 "Watercourses" including Sub-Script (4) of the Regulations of the Washoe County District Board of Health Governing Sewage, Wastewater, and Sanitation. EHS prepared a staff report and supporting documentation for a hearing of the SWS Board for May 7, 2018.

**BACKGROUND**

APN 017-123-05 is an undeveloped parcel within Washoe County which is served by a community water system but no community sewer system. The parcel has Bailey Creek running through it from the South to the North. Based on the creek and required setbacks to the bank, an onsite sewage disposal system could not be designed without crossing the creek. Furthermore, setbacks to the creek required reduction.

EHS worked with the property owner and their engineer to determine the best design for the parcel. It was determined the design would require a variance from the Regulations of the Washoe County District Board of Health Governing Sewage, Wastewater, and Sanitation.

**ENVIRONMENTAL HEALTH SERVICES**

1001 East Ninth Street | P.O. Box 11130 | Reno, Nevada 89520  
EHS Phone: 775-328-2434 | Fax: 775-328-6176 | washoecounty.us/health  
Serving Reno, Sparks and all of Washoe County, Nevada. Washoe County is an Equal Opportunity Employer.



Subject: SWS Hearing Advisory Board Meeting 050718  
Date: May 24, 2018  
Page 2 of 2

The property owner applied for a variance for the onsite sewage disposal design which was heard by the SWS Board on May 7, 2018. The Board unanimously voted to recommend approval of the variance to the DBOH with the following conditions:

1. Addition of geogrid fabric over the filter bed,
2. The electrical line sleeved in conduit, and
3. Show/provide a cross section profile view of creek crossing to WCHD.

### **FISCAL IMPACT**

There is no additional fiscal impact to the FY18 budget should the Board uphold the recommendation of the SWS Board to approve the variance request.

### **RECOMMENDATION**

EHS staff recommends the DBOH uphold the recommendation of the Sewage, Wastewater, and Sanitation Hearing Advisory Board with conditions for Variance #H18-0001VARI for APN 017-123-05, owned by Mike Fritz.

### **POSSIBLE MOTION**

Should the Board agree with staff's recommendation, a possible motion would be "Move to accept the recommendation of the Sewage, Wastewater, and Sanitation Hearing Advisory Board with conditions for Variance #H18-0001VARI for APN 017-123-05, owned by Mike Fritz.

## **Sewage, Wastewater and Sanitation Hearing Board Meeting Notice and Agenda**

### **Members**

Ronald J. Anderson, P.E., Chair  
Matthew Buehler  
Vonnie Fundin  
Nick Vestbie, P.E.  
Matt Smith - Alternate  
Ray Pezonella, P.E - Alternate

**Monday, May 7, 2018  
6:00 p.m.**

**Washoe County Administration Complex, Building B  
Health District South Conference Room  
1001 East Ninth Street  
Reno, NV**

---

**An item listed with asterisk (\*) next to it is an item for which no action will be taken.**

**6:00 p.m.**

- 1. \*Roll Call and Determination of Quorum**
- 2. \*Pledge of Allegiance**
- 3. \*Public Comment**

Any person is invited to speak on any item on or off the agenda during this period. Action may not be taken on any matter raised during this public comment period until the matter is specifically listed on an agenda as an action item.

- 4. Approval of Agenda – (For possible action)**  
May 7, 2018
- 5. Approval of Draft Minutes – (For possible action)**  
June 5, 2017
- 6. Public Hearing** to determine whether or not to recommend approval to the District Board of Health for a variance for APN 017-123-05 owned by Mike Fritz for Section 040.080 and Table 2 “Watercourses” including Sub-Script (4) of the Regulations of the Washoe County District Board of Health Governing Sewage, Wastewater, and Sanitation. – (**For possible action**)  
Staff Representative: James English  
  
Mr. Mike Fritz  
15425 Pinion Drive  
Reno, NV 89521  
Assessor’s Parcel Number 017-123-05
- 7. \*Public Comment**  
Any person is invited to speak on any item on or off the agenda during this period. Action may not be taken on any matter raised during this public comment period until the matter is specifically listed on an agenda as an action item.
- 8. Adjournment – (For possible action)**

---

**Possible Changes to Agenda Order and Timing:** Items on the agenda may be taken out of order, combined with other items, withdrawn from the agenda, moved to the agenda of another later meeting, moved to or from the Consent section, or they may be voted on in a block. Items with a specific time designation will not be heard prior to the stated time, but may be heard later. Items listed in the Consent section of the agenda are voted on as a block and will not be read or considered separately unless withdrawn from the Consent agenda.

**Special Accommodations:** The Sewage, Wastewater and Sanitation Board Meetings are accessible to the disabled. Disabled members of the public who require special accommodations or assistance at the meeting are requested to notify Administrative Health Services in writing at the Washoe County Health District, PO Box 1130, Reno, NV 89520-0027, or by calling 775.328.2415, 24 hours prior to the meeting.

**Public Comment:** During the “Public Comment” items, anyone may speak pertaining to any matter either on or off the agenda, to include items to be heard on consent. For the remainder of the agenda, public comment will only be heard during items that are not marked with an asterisk (\*). Any public comment for hearing items will be heard before action is taken on the item and must be about the specific item being considered by the Board. In order to speak during any public comment, each speaker must fill out a “Request to Speak” form and/or submit comments for the record to the Recording Secretary. Public comment and presentations for individual agenda items are limited as follows: fifteen minutes each for staff and appellant presentations, five minutes for a speaker representing a group, and three minutes for individual speakers unless extended by questions from the Board or by action of the Chair.

**Response to Public Comment:** The Sewage, Wastewater and Sanitation Board can deliberate or take action only if a matter has been listed on an agenda properly posted prior to the meeting. During the public comment period, speakers may address matters listed or not listed on the published agenda. The *Open Meeting Law* does not expressly prohibit responses to public comments by the Sewage, Wastewater and Sanitation Board. However, responses from the Board members to unlisted public comment topics could become deliberation on a matter without notice to the public. On the advice of legal counsel and to ensure the public has notice of all matters the Sewage, Wastewater and Sanitation Board will consider, Board members may choose not to respond to public comments, except to correct factual inaccuracies, ask for Health District Staff action or to ask that a matter be listed on a future agenda. The Sewage, Wastewater and Sanitation Board may do this either during the public comment item or during the following item: “Board Comments – Limited to Announcement or Issues for future Agendas.”

**Posting of Agenda; Location of Website:**

Pursuant to NRS 241.020, Notice of this meeting was posted at the following locations:

Washoe County Health District, 1001 E. 9th St., Reno, NV  
Downtown Reno Library, 301 S. Center St., Reno, NV  
Reno City Hall, 1 E. 1st St., Reno, NV  
Sparks City Hall, 431 Prater Way, Sparks, NV  
Washoe County Administration Building, 1001 E. 9th St, Reno, NV  
Washoe County Health District Website [www.washoecounty.us/health](http://www.washoecounty.us/health)  
State of Nevada Website: <https://notice.nv.gov>

**How to Get Copies of Agenda and Support Materials:** Supporting materials are available to the public at the Washoe County Health District located at 1001 E. 9<sup>th</sup> Street, in Reno, Nevada. Ms. Laura Rogers, Administrative Secretary to the District Board of Health is the person designated by the Washoe County District Board of Health to respond to requests for supporting materials. Ms. Rogers is located at the Washoe County Health District and may be reached by telephone at (775) 328-2415 or by email at [lrogers@washoecounty.us](mailto:lrogers@washoecounty.us). Supporting materials are also available at the Washoe County Health District Website [www.washoecounty.us/health](http://www.washoecounty.us/health) pursuant to the requirements of NRS 241.020.

**SEWAGE, WASTEWATER, AND SANITATION HEARING BOARD  
MEETING MINUTES EXCERPT**

**Members**

Ronald J. Anderson, P.E., Chair  
Steven H. Brigman, P.E., Vice Chair  
Michele C. Dennis, P.E.  
Matthew Buehler  
Vonnie Fundin

**Monday, June 5, 2017**

**6:00 p.m.**

**Washoe County Administration Complex  
Health District South Conference Room  
1001 East Ninth Street  
Reno, NV**

---

**6:00 p.m.**

**1. \*Roll Call and Determination of Quorum**

Chair Anderson called the meeting to order at 6:03 p.m.

The following members and staff were present:

Members present: Ronald J. Anderson, P.E., Chair  
Steven H. Brigman, P.E., Vice Chair  
Matthew Buehler

Members absent: Vonnie Fundin  
Michele C. Dennis, P.E.

**Ms. Rogers verified a quorum was present.**

**2. \*Public Comment**

As there was no one wishing to speak, Chair Anderson closed the public comment period.

**3. Approval of Draft Minutes**

March 10, 2016

Mr. Buehler moved to accept the minutes of the March 10, 2016 Sewage, Wastewater, & Sanitation Board (SWS Board) regular meeting as written. Vice Chair Brigman seconded the motion which was approved three in favor and none against.

**4. Public Hearing** to consider staff's recommendation to deny the appeal of the District Health Officer's decision as based on the requirements of Section 040.085 of the Washoe County District Board of Health Regulations Governing Sewage, Wastewater, & Sanitation – On-site sewage disposal systems are prohibited in any area subject to vehicular traffic. Section 010.185 defines an Onsite Sewage Disposal System as a system for sewage collection, treatment and disposal located on an individual parcel as approved by the Health Authority. Section 010.065 defines disposal area as that portion of the on-site sewage disposal system area which contains the disposal trench(es), the designated repair area for the disposal trench(es), provides for the required trench separations and meets the required setbacks.

Staff Representative: James English

Mr. Harley La Roche  
3810 Macaw Ln.  
Reno, NV 89508  
Assessor's Parcel Number 087-213-09 Parcel 10, Block E  
Cold Springs Valley Homes 2 Washoe County, NV

Mr. English stated that this item is in regards to a citizen who is appealing a decision of staff and the District Health Officer regarding his repair location and the requirement of having the area readily available in the event of septic failure. Mr. English informed that the home was built in 1987, and regulations at that time did not require a reserve or repair area as they do today. He noted that the home has been remodeled once. Currently, the homeowner is trying to build a detached garage on the property, but the proposed location is in the area that the Health District had designated for the repair area at the time of the remodel in 2006. The subsequent location suggested by the owner to EHS for the repair area was the driveway at the front of the house.

Mr. English explained that current staff protocol is to make sure the repair area is readily available for the most expedient repair to prevent potential public health issues, and to complete the repair as inexpensively as possible.

Mr. English informed that Mr. La Roche appealed staff's decision to the Division Director (Mr. Bob Sack, retired 3/31/2017). Mr. Sack upheld staff's decision to require the driveway be removed at the time to make the area accessible. Mr. La Roche then appealed the Division Director's decision to the District Health Officer who again upheld staff's decision.

Chair Anderson inquired if it had been recommended to Mr. La Roche to involve a professional engineer to draw plans for a repair design.

Mr. English responded that Mr. La Roche had been given multiple options and was not positive that this had been provided as a possibility, although he had been informed that the repair area could potentially require an engineer be involved due to the possible requirement of pumping based on fall. Mr. English opined that the house was probably designed as the rest of the area with the tank and the field in the middle of the back yard. With Mr. La Roche's proposed building location, the hard piping for sewage would have to be installed under and to the front of the house, where there may not be sufficient fall. Mr. English opined it was probable that Mr. La Roche had been encouraged to involve a professional engineer.

Chair Anderson noted that design preparation from the last case heard by the SWS Board was done without the input of a professional engineer. Chair Anderson stated that, in the past, County staff has discouraged professional engineers or indicated that professional engineers are not needed for standard designs, and understood that there was an initiative to change regulations and phase out this committee. The point of these comments, he stated, was that he'd been able to design an alternative plan for the design that didn't require a variance or being installed in the driveway. He opined that retaining a professional engineer would have resolved the issue immediately.

Mr. English stated that previous staff may have discouraged the use of engineers, but current staff strongly encourages their involvement. He informed that staff has also been able to see various options available in their review of plans and have suggested those involved obtain the services of professional engineers. Mr. English continued that Environmental Health has worked with the engineering community more frequently due to these efforts.

In regards to proposed changes in regulations, Mr. English informed that he was never fully supportive of the direction of those changes, and that proposed changes have not moved forward at this time. He noted that there are no draft regulations being created at this time and current regulations continue to be the standard. Mr. English stressed that the Environmental Health



Division does not discourage the involvement of professional engineers in plan design. He stated that EHS has an engineer on staff and their group has discovered many options in plan design review.

With that said, Mr. English informed that it is usually the decision of the resident to exclude engineering services in plan design due to the expense, adding that he was not inferring that was the case in this instance.

Chair Anderson noted items on the staff report that were not to his approval, one being that his name had been omitted on the report. Another was the mention that repair areas were not required before 1988. Chair Anderson stated that he has been involved in engineering since the 1970's and had been involved in the design of this subdivision. Although he could not find the original perc report for the subdivision, he believed that the design required a primary and repair area. Also, he stated, as far as he knew, that requirement has been consistent through the years.

Chair Anderson informed that, on the Washoe County website, it references the 2003 edition of the SWS regulations, and he believed it should show the 2013 regulations.

Mr. English noted that EHS records do not show any repairs for Mr. La Roche's home. As explained to him by his predecessors, Mr. English had been informed that previous repairs were not always required to be detailed on plans as is the procedure today.

Vice Chair Brigman agreed that there appeared to be other options available for Mr. La Roche that would avoid having to designate the driveway as a repair area. He stated that this design was not acceptable, and did not wish to set precedent by allowing it in this instance. Vice Chair Brigman asked if infiltrator chambers had been considered due to their small footprint.

Vice Chair Brigman opined that EHS had informed Mr. La Roche that it would be nearly impossible to obtain Board's approval to install a repair field under the driveway.

Mr. La Roche stated that had never been his intention. He explained his plan was to remove the drive way to expose area for a repair field at such a time the septic system failed, but not until. He informed that the area proposed for use as a repair field was not an area necessary for access to his garage as it is an area of a circular drive.

Mr. La Roche introduced himself as the owner of the property and informed that on the first set of plans submitted, it showed two forty-foot leach fields to be installed in the future. He indicated that the report shows only one. This plan had been rejected. He then designed the leach field to the front of the property, which meets set-back requirements, but it was required that the asphalt had to be removed immediately.

Mr. La Roche informed that there is sewer line at the school approximately 700-800 feet away from his property. An employee of the sewer company that services the school indicated the possibility of sewer services extending to the area of Mr. La Roche's home in 3-5 years. He stated that this gave him hope that a solution would be available before the septic might fail, and indicated that it would take minimal time to remove the asphalt should the septic fail.

Chair Anderson asked Mr. La Roche if he would be willing to hire an engineer design a plan that would be acceptable.

Mr. La Roche agreed that he would do so at the time the septic fails, if it does. He stated that he had with him Mr. Dave Jones, a soils expert, for the Board to question if they had wanted specific information on the soil type at the property. Mr. La Roche stressed that he was willing to remove the asphalt, but did not want to do so until necessary. He stated there was no way to estimate how long the septic system will last, that he is the only occupant in the residence and he maintains the system regularly.

Mr. Anderson stated that it was his understanding of Mr. La Roche's position that he was unwilling to hire a professional engineer in order to resolve this situation.

Mr. La Roche opined that it would be a waste of capital at this point, since the septic system

is sound at this point and that future connection to sewer would be thousands of dollars. He stated that he would be willing to sign documents on that property stating that the asphalt will have to be removed if the septic system fails to and the back-up area needs to be used.

Chair Anderson asked for comments and there were none.

Mr. Jones introduced himself as working for Construction Materials Engineers and as a professional geologist in the States of California and Idaho, noting that Nevada does not have a registration. He stated that his work is leach field analysis, perc tests and soil analysis to determine the design of septic systems, and that Mr. La Roche had requested him to review his documents and provide feedback. He noted that there were probably alternate designs that could be used for the repair field to the back of the lot by either extending the existing trench or creating several other diagonal options that would meet the offset requirements at the back of the property. Mr. Jones stated that Mr. La Roche made it clear to him that the area designated for the proposed repair area is not his primary access to his garage. If that area were utilized, Mr. La Roche would have full access to his garage without infringing on the repair field. If the system fails, he would then hire an engineer to design and build the repair field either in the front or back of the property, removing the asphalt removed as necessary.

Mr. La Roche informed that the dimensions of the garage, if reduce to 200 square feet, could be built without code requirements other than zoning. His proposed design is 280 square feet and would prefer that size.

Mr. English informed that this is not the first instance that the location of a repair field has been the subject of contention, and that the decision the Board makes today could set precedent in future plan review. He informed that EHS have had other individuals remove both concrete and asphalt driveways in similar situations due to there being no other option to locate a repair field with the plans for their project.

Mr. English also noted that there have been properties sold to persons that had not been made aware of decisions such as this and then are faced with unexpected and costly repair.

Mr. English informed that the only requirements for sewer under regulations are the 200 and 400 foot limitations. Proposal for options outside of those limits where there is no regulatory jurisdiction has only happened once before, and those were commercial plans that the developer bonded the cost of the connection to sewer at 750 feet.

Mr. Buehler asked if there was a way to incorporate a grading or access material to protect it from compaction under a concrete or asphalt drive.

Mr. English stated that he did not believe that it was Mr. La Roche's plan to cover the area with concrete or asphalt should he have to install the septic system. He informed the reason Mr. La Roche's plans were denied is because he did not want to remove the driveway at this time, and that this has always been standard procedure at Environmental Health Services. Mr. English reiterated that the Division Director and the District Health Officer both upheld staff's position, and that EHS would never approve a driveway to be installed over a repair field, unless it were completely engineered and those plans approved by EHS; but interpretation of the regulations require the field to be available prior to construction.

Mr. La Roche stated that he has been a licensed general contractor since 1980 and prior to that had been a spec builder and has built homes throughout Washoe County. It was required to show a back-up septic system on these builds. He indicated that, in a meeting with Health Officer it was disclosed that a system could be covered if approved as engineered. He also stressed that he wasn't requesting to be connected to the sewer system at that distance, but was noting that it was a future possibility for the entire area.

Vice Chair Brigman stated that he'd been on the SWS Board and couldn't recall ever seen or allowed a repair or primary field under a driveway whether paved or not. He noted that there

were possible options other than this driveway to locate a repair field and so would not be supportive of the plans as shown. He stressed that he did not wish to set a precedent that could result in multiple cases coming before the Board. Vice Chair Brigman stated that it was not a matter of Mr. La Roche's reluctance to remove the asphalt until necessary, that for him, it was basic design issues and in conflict with regulations that have been in place for a very long time.

Mr. La Roche reiterated that he doesn't have an issue in removing the asphalt at such a time the system fails, that there is no leach field there now, and would employ an engineer at the time to design and install the project, and that the area would no longer be a driveway. He continued that another option would be to have an engineer configure a design that would not involve the driveway area. He opined that to have to remove the asphalt before it is necessary is a hardship that should not be required of any taxpayer. He informed that he is a building inspector and understands the rigidity of regulations, that regulations can be interpreted in different ways, and asked for the Board to make their decision based on the most sensible interpretation.

Chair Anderson agreed that many issues are not clearly cut and that is the reason for the SWS Board. He stated that this instance to him was clear in that there are other options available to Mr. La Roche, the first being to hire an engineer to draw an acceptable plan, thereby resolving the issue of the asphalt.

Mr. Buehler asked there was a way to calculate the remaining feasibility of the septic system by area comparisons. Chair Anderson stated that was not a subject he wanted to pursue. He did note that he was not aware of many failures in the area. Mr. Jones informed that there were granular soils in the area that were amenable to a stable, quality leach field.

Mr. Buehler asked if there were a way to grant a limited time permit if the estimated life-span of the system could be calculated.

Chair Anderson opined that suggestion might be over-thinking the situation, because of the ease in which he was able to devise an alternate design.

**Vice-Chair Brigman moved to deny the appeal of the District Health Officer's decision based on the requirements of Section 040.085 of the Washoe County District Board of Health Regulations Governing Sewage, Wastewater, & Sanitation. Chair Anderson seconded the motion which was approved three in favor and none against.**

Mr. La Roche asked if he has an engineer propose a new area if it should be submitted to the Board or directly to EHS. Chair Anderson stated that it was not necessary to submit it to the Board.

## **6. \*Public Comment**

As there was no one wishing to speak, Chair Anderson closed the public comment period.

## **7. Adjournment**

At 6:45 p.m., Chair Anderson moved to adjourn the meeting. Vice Chair Brigman seconded the motion which was approved three in favor and none against.

---

Respectfully submitted,

---

James English, Environmental Health Specialist Supervisor  
Secretary to the Sewage, Wastewater and Sanitation Board

---

Laura Rogers, Administrative Secretary  
Recording Secretary

Approved by Board in session on \_\_\_\_\_, 2017.

## STAFF REPORT

**BOARD MEETING DATE: May 7, 2018**

**TO:** Sewage, Wastewater, and Sanitation Hearing Advisory Board

**FROM:** James English, EHS Supervisor  
775-328-2610, [jenglish@washoecounty.us](mailto:jenglish@washoecounty.us)

**SUBJECT:** Public Hearing to determine whether or not to recommend approval to the District Board of Health for a variance for APN 017-123-05 owned by Mike Fritz for Section 040.080 and Table 2 “Watercourses” including Sub-Script (4) of the Regulations of the Washoe County District Board of Health Governing Sewage, Wastewater, and Sanitation.

---

### SUMMARY

This staff report summarizes the Environmental Health Services Division’s (EHS) review of the submitted variance application for your decision to recommend or deny approval to the District Board of Health (DBOH) a variance for APN 017-123-05 which is owned by Mike Fritz. The variance requests reduced setbacks to a watercourse and to have a pressure sewage line cross Baily Creek.

### PREVIOUS ACTION

There has been no previous action with this variance request. The parcel is undeveloped at this time.

### BACKGROUND

Environmental Health Services Staff (EHS) has worked with both the property owner and the engineer to find the best possible solution to design an onsite sewage disposal system for this property. The property is 1.004 acres and served by a community water system, the parcel has Bailey Creek running through it flowing from south to north when water is present. During the design phase to build on the property and place an onsite sewage disposal system, it was determined there was no way to meet the setbacks required in Section 040.080 of the Regulations of the Washoe County District Board of Health Governing Sewage, Wastewater, and Sanitation (SWS Regulations).

The property owner contracted with Chad Carnes P.E. with Marvin E. Davis & Associates, Inc. to design an onsite sewage disposal system to be the most protective of the public and environmental health for the parcel. The proposed design has the building sewer lines, tanks and part of the engineered sand filter system within the 100 foot setback to the edge of the highest water level of Baily Creek as required in Section 040.080. The proposed repair or reserve sand filter location is also partially within the 100 foot setback of Baily Creek.

Additionally, the building sewer will have to cross Baily Creek. The proposed design has recommended the ejector line be encased in concrete, steel or PVC pipe with concrete plugs through the creek and beyond 25 feet of the top of the creek bank.

Staff have been on site to validate the proposed onsite sewage disposal system layout as it is in the field. Based on field observations and the property corners being marked, it is noted the proposed design and creek layout match the plans as submitted.

EHS staff note that if a primary and repair sewage disposal area cannot be agreed upon, this parcel will become un-buildable until such time that municipal sewer is within 400-feet to the property boundary.

EHS staff also received input from a concerned citizen regarding the proposed construction on the site and the creek crossing with a sewer line. The resident submitted photos of the creek from March of 2018 which are including in this report.

**Considerations for the Sewage, Wastewater and Sanitation Board (Board)**

The Board must consider the following when making a recommendation on this variance to the DBOH:

1. Will the proposed system significantly and/or adversely impact any water so that the water may no longer be used for its existing or expected beneficial use?

A test trench was excavated to 13 feet below ground surface and no groundwater was encountered. If standard trenches were proposed on the property, EHS would allow their depth to 9 feet. The proposed design is more protective of groundwater by using an engineered sand filter bed with an excavation depth of 4 feet below ground surface.

Baily Creek is a seasonal or intermittent creek, the water flows to Steamboat Creek and ultimately to the Truckee River. The beneficial use of the creek is to replenish the Truckee River. If the pressurized sewer line crossing the creek fails, it possibly could contaminate Baily Creek with raw sewage until such time as the flow was stopped.

2. Will the proposed system be detrimental or pose a danger to public health or safety or create or contribute to a public health hazard?

The proposed system design is the most conservative and protective of public health for the parcel. The majority of the sand filter beds are outside of the 100 foot setback to Bailey Creek. The sand filter beds are also only four feet below grade. The proposed sewer line crossing the creek is encased for protection. In a natural disaster or flood event the sewer line may be exposed or possibly damaged.

3. Are there other reasonable alternatives for compliance with these regulations that are available to the applicant?

EHS staff sees the only other reasonable alternative may be to make the sand filter bed a raised system to increase separation to groundwater, although this may make it more vulnerable to damage in a major flood event. Another alternative may be to possibly change or redesign the creek crossing to be more protective of public health. The current proposed design is for the line to be buried 30 inches below the existing creek bed and be encased through the creek bed extending to either side for a minimum of 25 feet. Other than these options, EHS staff does not see any other feasible alternatives.

### **Conditions of approval**

EHS staff asks the SWS Board to evaluate the proposed variance to determine if they will recommend it to the DBOH for approval. If the recommendation for approval is made, staff asks that the SWS Board to consider the following conditions for the variance:

1. Recommend minimum setbacks to Bailey Creek for the siting of the sand filter beds and other components of the onsite sewage disposal system. This condition allows for there to be some flexibility in design and construction based on field conditions.
2. Evaluate the pressure building sewer line which crosses the creek and determine if the proposed design is adequate and protective of the environment.
3. Require recording of the variance to the parcel to ensure proper public records notification in the event the property is sold to any other person or entity.

### **RECOMMENDATION**

Based on the information presented, staff recommends: The Sewage, Wastewater, and Sanitation Hearing Advisory Board determine whether or not to recommend approval to the District Board of Health for a variance for APN 017-123-05 owned by Mike Fritz for Section 040.080 and Table 2 “Watercourses” including Sub-Script (4) of the Regulations of the Washoe County District Board of Health Governing Sewage, Wastewater, and Sanitation and if it is determined to recommend approval the Board determine what if any conditions to place on the variance.

### **POSSIBLE MOTION**

Should the Board agree with staff’s recommendation, the three possible motions would be:

1. “Move to recommend denial of the variance to the District Board of Health for a variance for APN 017-123-05 owned by Mike Fritz for Section 040.080 and Table 2 “Watercourses” including Sub-Script (4) of the Regulations of the Washoe County District Board of Health Governing Sewage, Wastewater, and Sanitation; OR
2. “Move to recommend approval of the variance to the District Board of Health for a variance for APN 017-123-05 owned by Mike Fritz for Section 040.080 and Table 2 “Watercourses” including Sub-Script (4) of the Regulations of the Washoe County District Board of Health Governing Sewage, Wastewater, and Sanitation with the following conditions: (list conditions)”; OR

3. “Move to recommend approval of the variance to the District Board of Health for a variance for APN 017-123-05 owned by Mike Fritz for Section 040.080 and Table 2 “Watercourses” including Sub-Script (4) of the Regulations of the Washoe County District Board of Health Governing Sewage, Wastewater, and Sanitation without conditions.”



WASHOE COUNTY  
HEALTH DISTRICT  
ENHANCING QUALITY OF LIFE

WASHOE COUNTY HEALTH DISTRICT  
ENVIRONMENTAL HEALTH SERVICES DIVISION  
1001 East Ninth Street • PO Box 11130 • Reno, Nevada 89520  
Telephone (775) 328-2434 • Fax (775) 328-6176  
www.washoecounty.us/health

Office Use Only

Fee Paid \_\_\_\_\_  
Date Paid \_\_\_\_\_  
Cash/CC/Check \_\_\_\_\_  
Receipt No. \_\_\_\_\_  
Date Appl. Received \_\_\_\_\_  
Considered Comp. \_\_\_\_\_

APPLICATION FOR VARIANCE  
TO THE REGULATIONS GOVERNING SEWAGE,  
SANITATION AND WASTEWATER

DATE 03/02/18 PROJECT NAME Fritz Residence

**OWNER**

Name Mike Fritz

Address PO Box 17043, Reno, NV 89511

Phone (775) 843-2802

Email Address mfritz518@gmail.com

**ENGINEER**

Name Chad Carnes, P.E.

Address PO Box 18449, Reno, NV 89511

Phone (775) 853-9100

Email Address ccarnes@mdageotechnical.com

**The following items must be submitted with this application:**

JOB ADDRESS 15425 Pinion Drive, Reno, Washoe County, Nevada 89521

SIZE OF PARCEL 1.004 /Acre

COPY OF LEGAL DESCRIPTION AND VERIFICATION OF CURRENT VESTING ON TITLE

EXISTING PARCEL(S) APN(S) 017-123-05 LOT N/A BLOCK N/A

REASON FOR VARIANCE REQUEST Allow for the construction of disposal system improvements on west end of the property; being the most usable area which provides separation from Bailey Creek 100'. Bank setback is encroached, and creek must be crossed with service line.

SECTION(S) OF REGULATIONS TO BE VARIED Section 040.080, Table 2 "Watercourses" including Sub-Script (4)

IF A PARCEL MAP: PROJECT NAME N/A

APN(S) \_\_\_\_\_ LOT \_\_\_\_\_ BLOCK \_\_\_\_\_

IF TENTATIVE MAP: PROJECT NAME N/A

NUMBER OF PROPOSED LOTS \_\_\_\_\_ LOTS REQUIRING VARIANCES \_\_\_\_\_

LOT DESCRIPTION(S) \_\_\_\_\_

**Prepare and submit this original application with 9 copies and 10 copies of a construction plot plan with specifications drawn to scale (minimum 1 inch = 30 feet) and include the required following requirements:**

- Vicinity map.
- The direction of North.
- A diagram of the location of roadways, easements or areas subject to vehicular traffic, material storage or large animal habitation.

... continued from previous page

- A diagram of the location and distance to any well and on-site sewage disposal system within 150 feet of the subject property (if none, so indicate).
- A diagram of the distances from the proposed on-site disposal system to any proposed or existing on-site well.
- A diagram of the location of any percolation hole or test trench(es) on the property.
- A diagram to scale of the location of all proposed on-site sewage disposal system components, including a delineated area for future replacement of disposal trench(es).
- A diagram of the distance to any available sewer system (if none, so indicate).
- The number of bedrooms in the proposed building.
- The maximum slope across the disposal area.
- A diagram of the lot dimensions and total lot area.
- The location of water supply lines.
- A diagram of all structures on site.
- A diagram of all existing and proposed drainage improvements.
- A diagram of the location of any watercourse and/or natural drainage channel within 150 feet of the property (if none, so indicate).
- Soil logs and percolation test results, including calculations and actual field data (if required).
- Sewage loading calculations and application rates.
- System sizing calculations.
- Pertinent geological and hydrogeological information.
- Construction drawings, cross-sections and specifications of the proposed system.
- Certification by an engineer that the proposed system is properly designed to function for at least ten (10) years (engineer's seal).
- Submit a completed Notice of Special On-Site Requirements. We will give you the form after variance is approved by the District Board of Health.

**BE PREPARED TO SUBMIT:**

- Other information may be required to enable the Board to adequately consider the application.

**THE SUBMITTED DATA, DOCUMENTS AND DESIGNS MUST DEMONSTRATE WHETHER:**

1. The proposed system will significantly and/or adversely impact any water so that the water may no longer be used for its existing or expected beneficial use.
2. The proposed system will be detrimental or pose a danger to the public health, safety or create or contribute to a public health hazard.
3. Other reasonable alternatives for compliance with these regulations are available to the applicant. State the alternatives considered, including reasons for rejection.

172400ALL INFORMATION MUST BE PROVIDED AND THIS APPLICATION MUST BE PROPERLY COMPLETED PRIOR TO SUBMITTAL. FAILURE TO DO SO MAY RESULT IN SIGNIFICANT DELAYS TO THE PROCESSING OF THIS VARIANCE REQUEST.

REV.	DATE	BY	APP'D

Marvin E. Davis & Associates, Inc.  
 CONSULTING CIVIL ENGINEERS  
 P.O. Box 18449  
 Reno, Nevada 89511  
 TEL (775)853-9100  
 FAX (775)853-9199

ON-SITE DISPOSAL DETAILS  
 VARIANCE APPLICATION FOR:  
 FRITZ RESIDENCE  
 15425 PINION DRIVE  
 APN: 017-123-05  
 WASHOE COUNTY  
 NEVADA

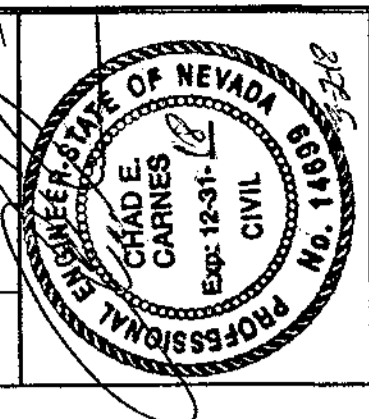

DATE: 03/02/18  
 JOB NUMBER: 17104.001  
 DESIGNED BY: CEC  
 DRAWN BY: CEC  
 CHECKED BY: CEC  
 SHEET

SD2

PROJECT NAME: FRITZ RESIDENCE - 15425 PINION DRIVE HOLE NO.: TP-1  
 ASSESSOR'S PARCEL NUMBER: 017-123-05 DATE: 6/14/14  
 LOCATION OF TEST HOLE: REFERENCE THIS PLAN SURFACE ELEVATION: 4746  
 DATE COMPLETED: December 5, 2017  
 DEPTH TO GROUNDWATER: NOT ENCOUNTERED, NO EVIDENCE OF GROUNDWATER

DEPTH	SOIL DESCRIPTION
0'-1'	LIGHT BROWN SILTY SAND (SM) W/ GRAVEL, DRY, LOOSE.
1'-5'	ABUNDANT FINE STRAINED ORGANICS
5'-13'	BROWN GRAVEL W/ SAND (GM), SLIGHTLY MOIST, MEDIUM DENSE, TRACE ORGANICS
	INCREASING COBBLE CONTENT BELOW 5' W/ BOULDERS TO 18"

PERCOLATION TEST DATA P-1	
TIME INTERVAL (MIN)	PERCOLATION RATE (MIN/IN)
10	3"
10	2-7/8"
10	2-1/4"
10	2"
10	1-3/4"
10	1-7/16"
10	1-3/8"
10	7.3

TEST DEPTH BELOW GROUND SURFACE: 2.5 FEET

PERCOLATION TEST DATA P-2	
TIME INTERVAL (MIN)	PERCOLATION RATE (MIN/IN)
10	2-5/8"
10	2-5/8"
10	2-3/8"
10	2-1/8"
10	1-15/16"
10	1-3/4"
10	1-3/4"
10	5.7

TEST DEPTH BELOW GROUND SURFACE: 5.0 FEET

DESIGN AND CONSTRUCTION NOTES:  
 RESIDENCE: 4 BEDROOM REQUIRING A 1500 GALLON SEPTIC TANK.  
 SOIL TYPE: BROWN GRAVEL W/ SAND (GM).  
 GROUND WATER SEASONAL MAX: GREATER THAN 13 FEET.  
 DEPTH TO IMPERVIOUS SOIL: NOT APPLICABLE.  
 DESIGN PERCOLATION RATE: 15 minutes per inch (COMPENSATES FOR ROCK).  
 LEACH FIELD TYPE: SAND FILTER BED SYSTEM.  
 DESIGN:  $Q = \frac{V}{t}$  WHERE Q=APPLICATION RATE (gpd/sq.ft.), t=DESIGN PERCOLATION RATE (minutes/inch)  
 (BED SIZING WILL BE CONTROLLED BY PERCOLATION RATE)  
 $Q = \frac{5}{15} = 1.29 \text{ gpd/sq.ft.}$   
 FOR MAIN RESIDENCE  
 BED AREA:  $A = 150 \text{ sq. ft.}$   
 $1.29 \text{ gpd/sq.ft.} \times 150 \text{ sq.ft.} = 193.5 \text{ gpd}$   
 FOR FUTURE WORKSHOP  
 BED AREA:  $A = 50 \text{ sq. ft.}$   
 $1.29 \text{ gpd/sq.ft.} \times 50 \text{ sq.ft.} = 64.5 \text{ gpd}$   
 COMBINED AREA = 582.1

DESIGN AND CONSTRUCTION NOTES:  
 RESIDENCE: 4 BEDROOM REQUIRING A 1500 GALLON SEPTIC TANK.  
 SOIL TYPE: BROWN GRAVEL W/ SAND (GM).  
 GROUND WATER SEASONAL MAX: GREATER THAN 13 FEET.  
 DEPTH TO IMPERVIOUS SOIL: NOT APPLICABLE.  
 DESIGN PERCOLATION RATE: 15 minutes per inch (COMPENSATES FOR ROCK).  
 LEACH FIELD TYPE: SAND FILTER BED SYSTEM.  
 DESIGN:  $Q = \frac{V}{t}$  WHERE Q=APPLICATION RATE (gpd/sq.ft.), t=DESIGN PERCOLATION RATE (minutes/inch)  
 (BED SIZING WILL BE CONTROLLED BY PERCOLATION RATE)  
 $Q = \frac{5}{15} = 1.29 \text{ gpd/sq.ft.}$   
 FOR MAIN RESIDENCE  
 BED AREA:  $A = 150 \text{ sq. ft.}$   
 $1.29 \text{ gpd/sq.ft.} \times 150 \text{ sq.ft.} = 193.5 \text{ gpd}$   
 FOR FUTURE WORKSHOP  
 BED AREA:  $A = 50 \text{ sq. ft.}$   
 $1.29 \text{ gpd/sq.ft.} \times 50 \text{ sq.ft.} = 64.5 \text{ gpd}$   
 COMBINED AREA = 582.1

DESIGN AND CONSTRUCTION NOTES:  
 RESIDENCE: 4 BEDROOM REQUIRING A 1500 GALLON SEPTIC TANK.  
 SOIL TYPE: BROWN GRAVEL W/ SAND (GM).  
 GROUND WATER SEASONAL MAX: GREATER THAN 13 FEET.  
 DEPTH TO IMPERVIOUS SOIL: NOT APPLICABLE.  
 DESIGN PERCOLATION RATE: 15 minutes per inch (COMPENSATES FOR ROCK).  
 LEACH FIELD TYPE: SAND FILTER BED SYSTEM.  
 DESIGN:  $Q = \frac{V}{t}$  WHERE Q=APPLICATION RATE (gpd/sq.ft.), t=DESIGN PERCOLATION RATE (minutes/inch)  
 (BED SIZING WILL BE CONTROLLED BY PERCOLATION RATE)  
 $Q = \frac{5}{15} = 1.29 \text{ gpd/sq.ft.}$   
 FOR MAIN RESIDENCE  
 BED AREA:  $A = 150 \text{ sq. ft.}$   
 $1.29 \text{ gpd/sq.ft.} \times 150 \text{ sq.ft.} = 193.5 \text{ gpd}$   
 FOR FUTURE WORKSHOP  
 BED AREA:  $A = 50 \text{ sq. ft.}$   
 $1.29 \text{ gpd/sq.ft.} \times 50 \text{ sq.ft.} = 64.5 \text{ gpd}$   
 COMBINED AREA = 582.1

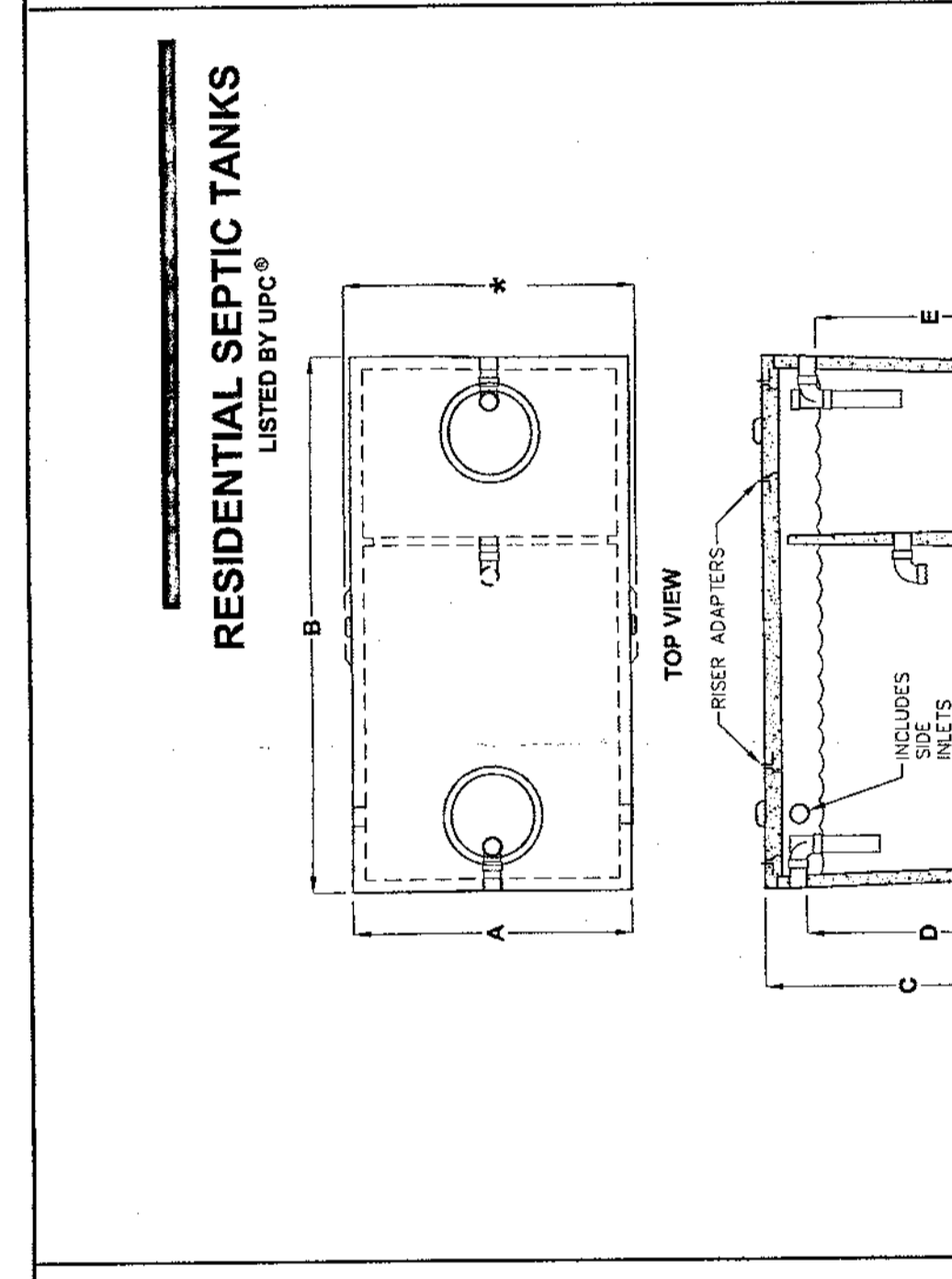

MODEL NUMBER	LIQUID CAPACITY (GALLONS)	DM A	DM B	DM C	DM D	DM E	MINIMUM ELEVATION	MINIMUM EXCAVATION
US-1000	1000	15'-1"	8'-2"	5'-8"	4'-10"	4'-7"	6'-10"	9'-2"
US-1200	1200	15'-3"	8'-6"	5'-8"	4'-10"	4'-7"	7'-6"	9'-6"
US-1500	1500	15'-3"	10'-8"	5'-8"	4'-10"	4'-7"	7'-4"	11'-3"
US-2000	2000	15'-11"	15'-11"	5'-8"	4'-10"	4'-7"	6'-8"	18'-11"
US-2500	2500	15'-11"	15'-11"	5'-8"	4'-10"	4'-7"	7'-5"	17'-10"
US-3000	3000	15'-5"	18'-10"	6'-5"	5'-7"	5'-4"	7'-8"	17'-10"

DESIGN LOAD: NON-TRAFFIC WITH 3" EARTH COVER MAXIMUM AT 800 PSF.  
 FOR COMPLETE DESIGN AND PRODUCT INFORMATION CONTACT JENSEN PRECAST.

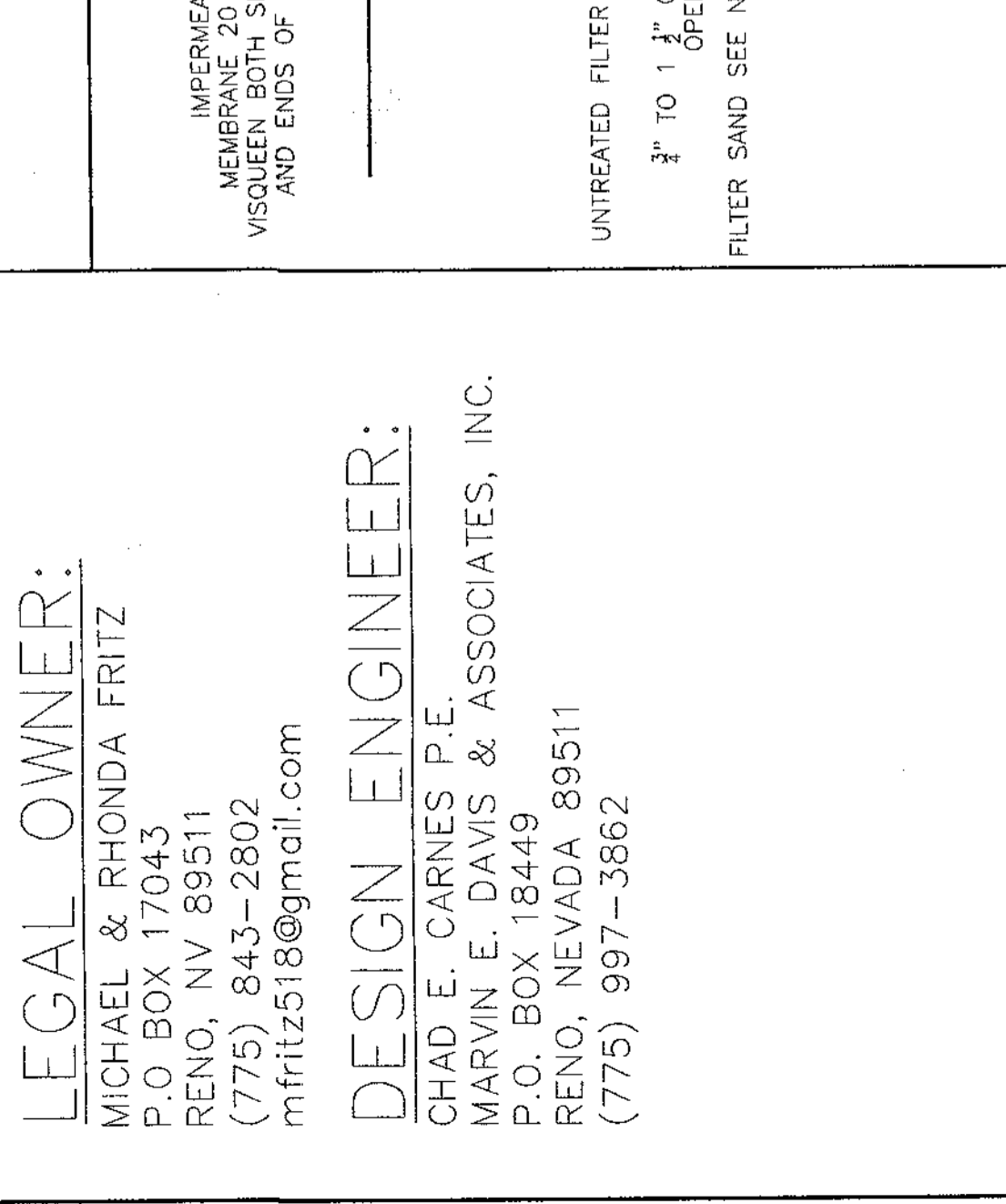
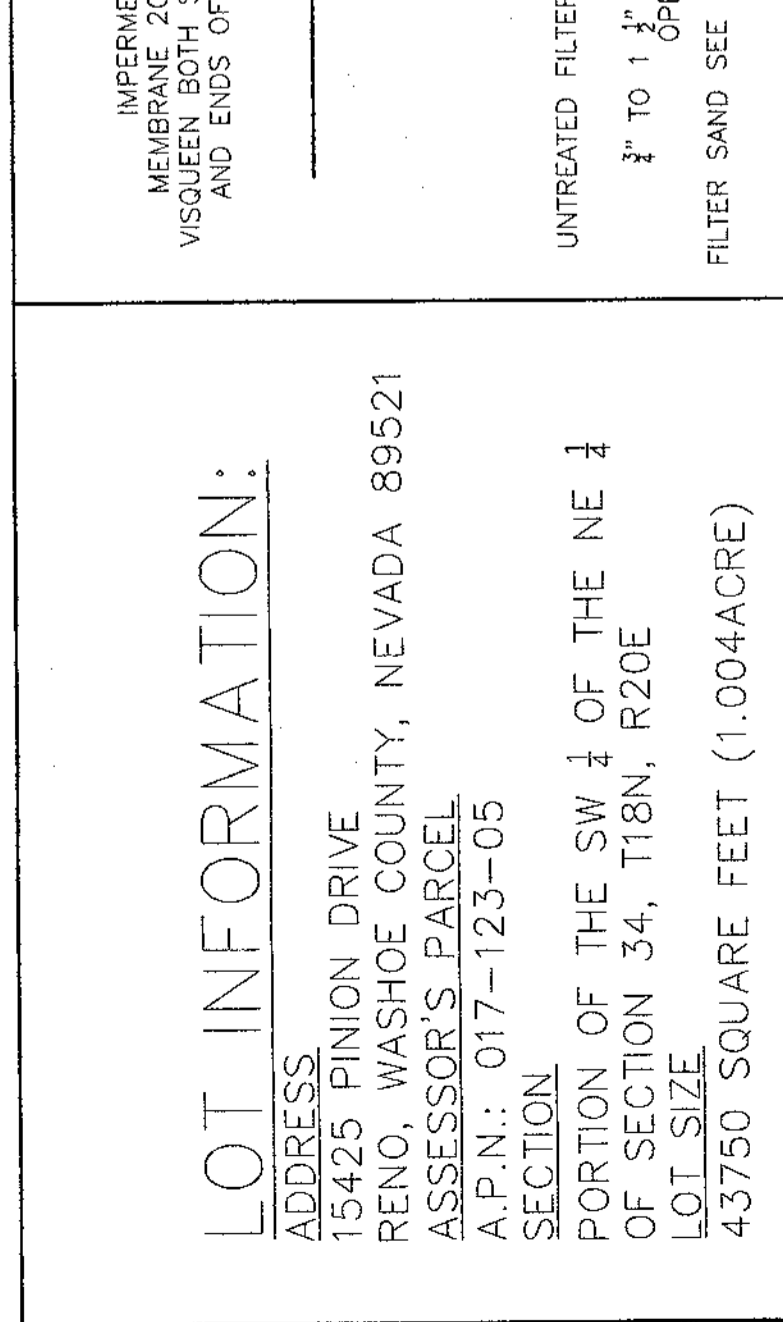
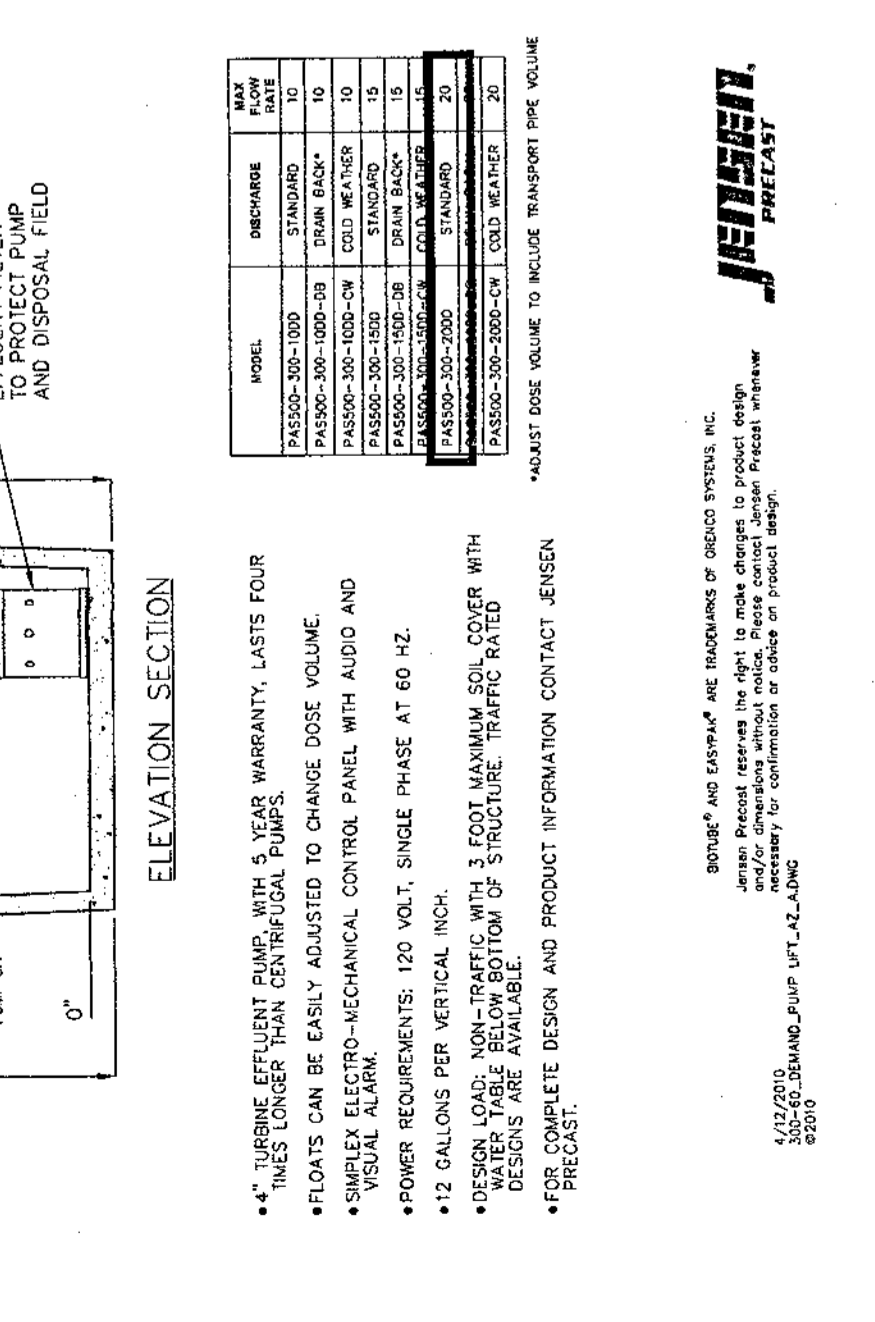
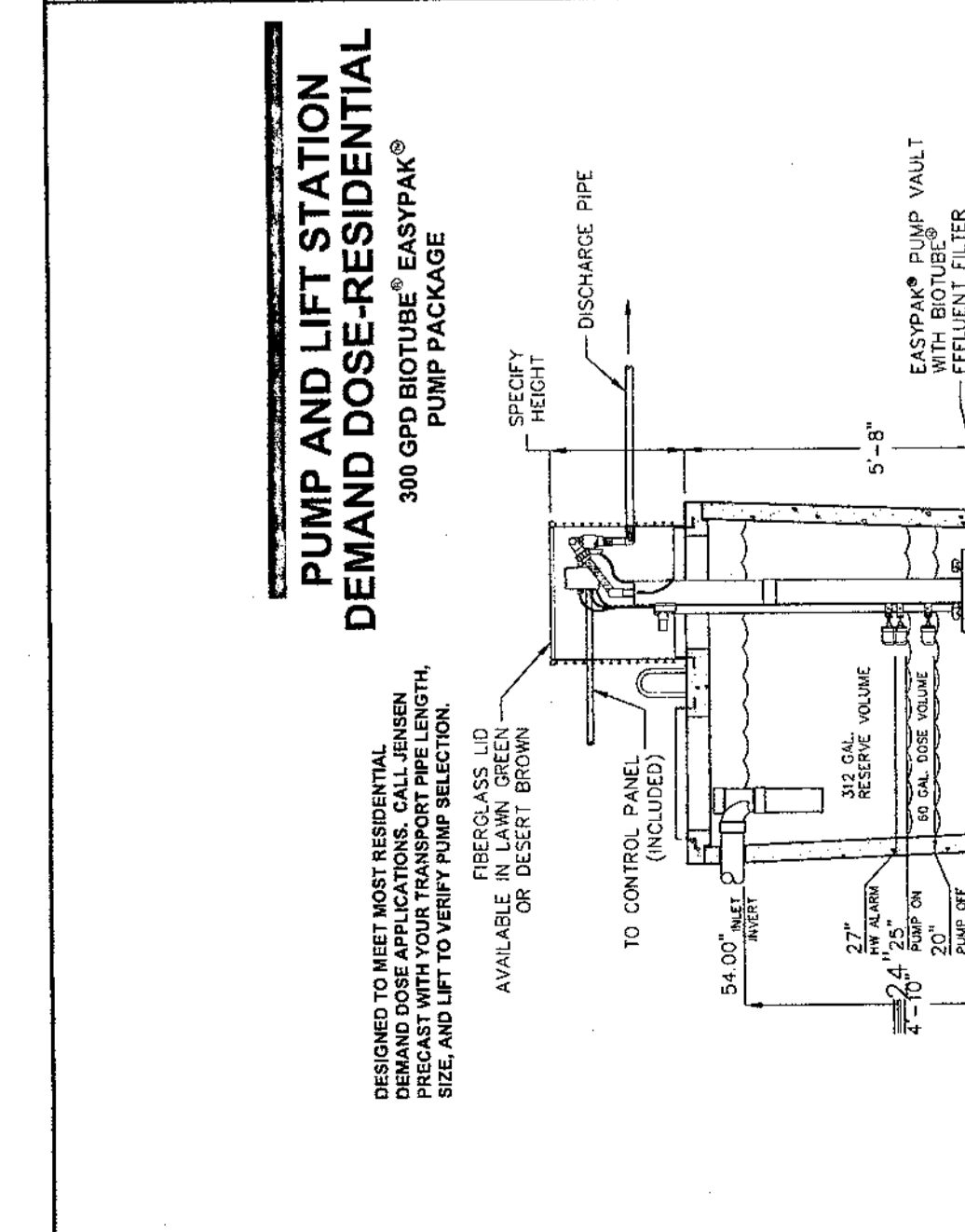
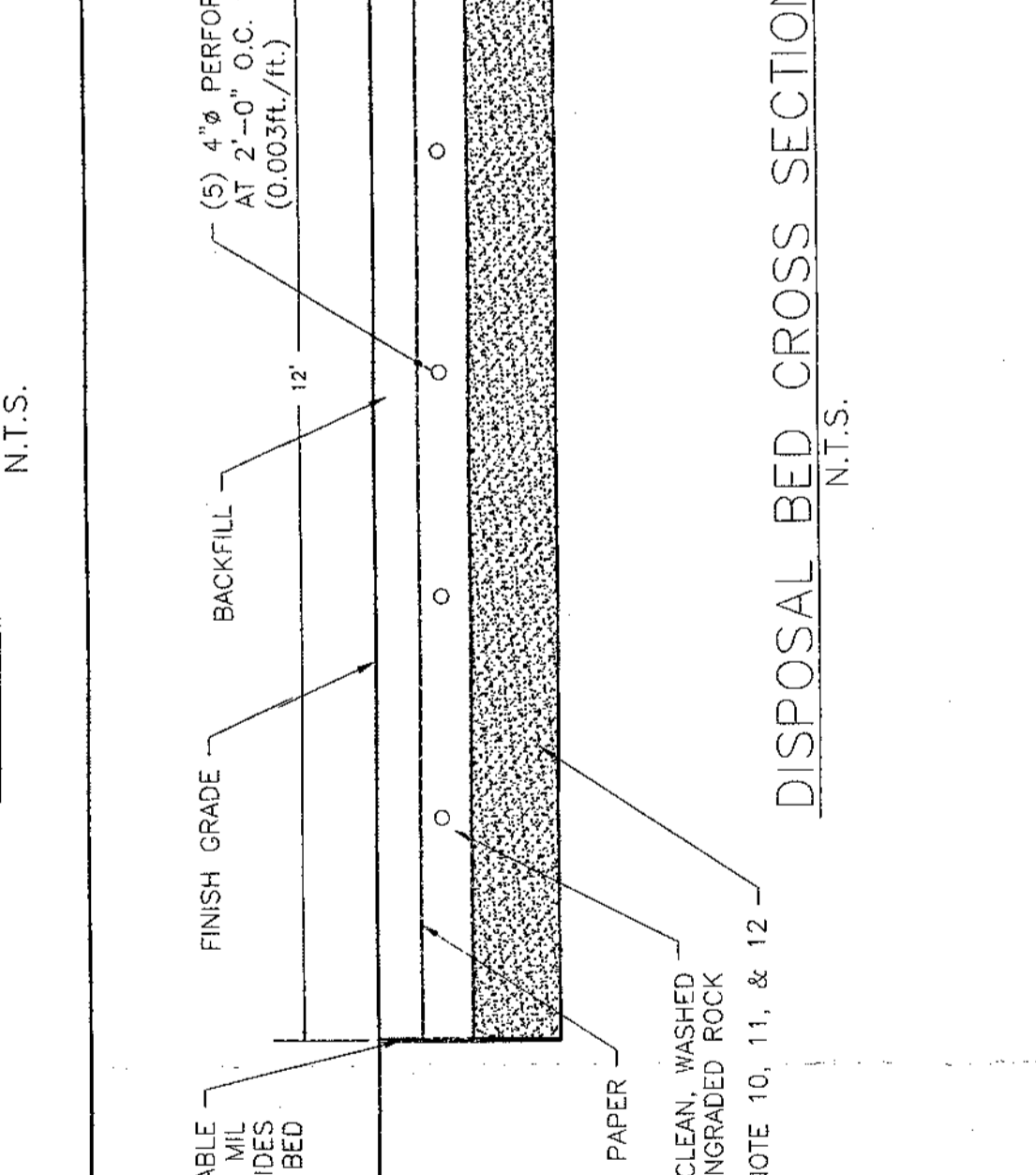
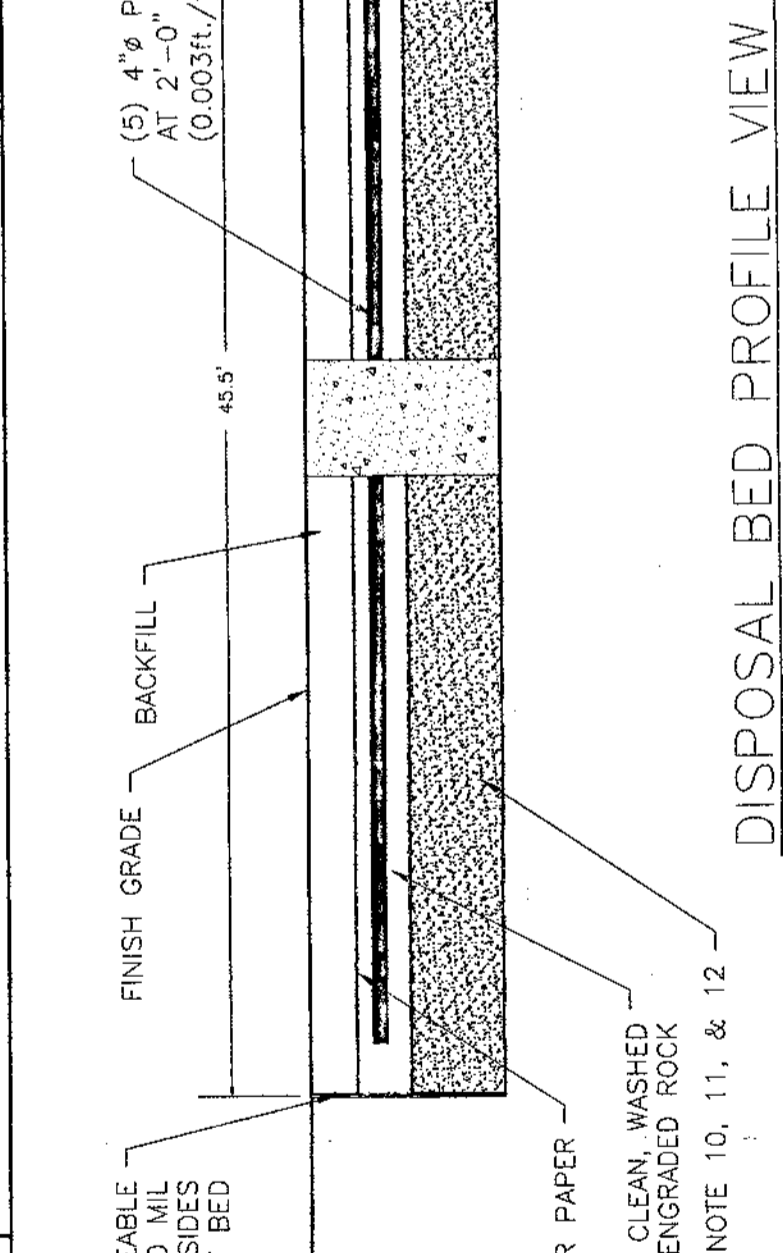
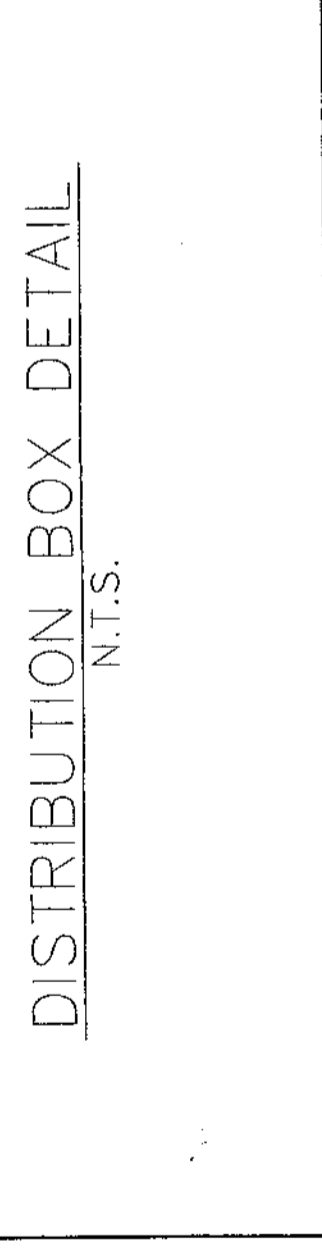
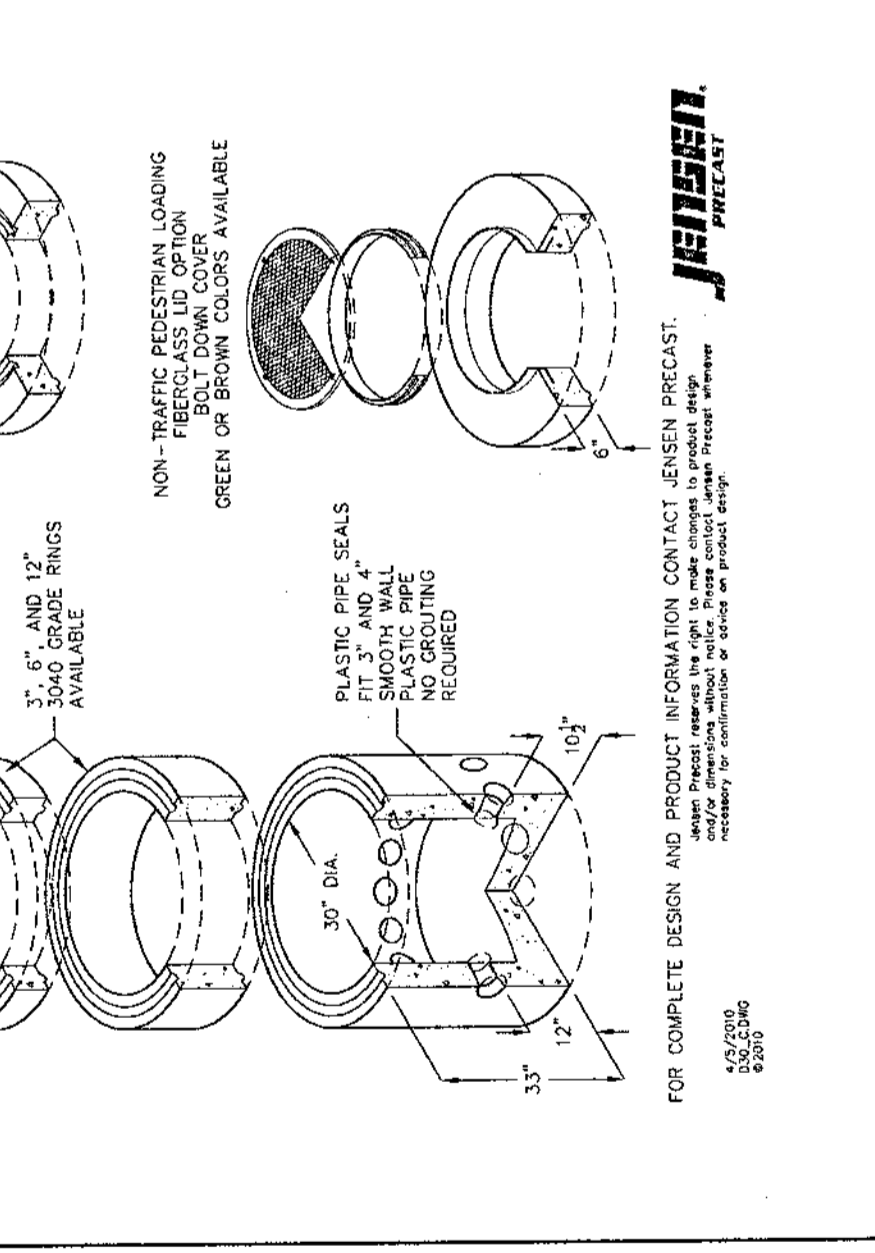
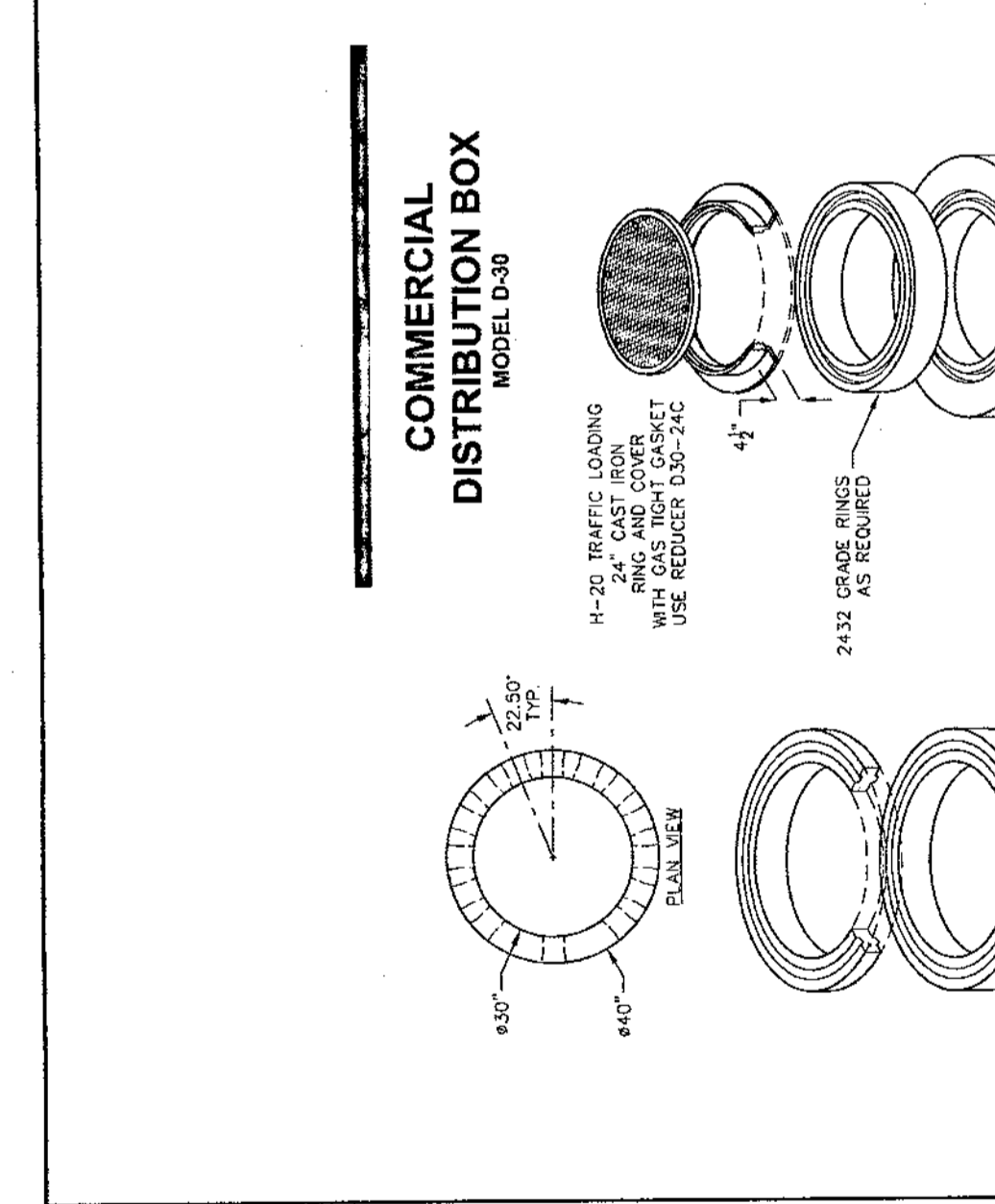
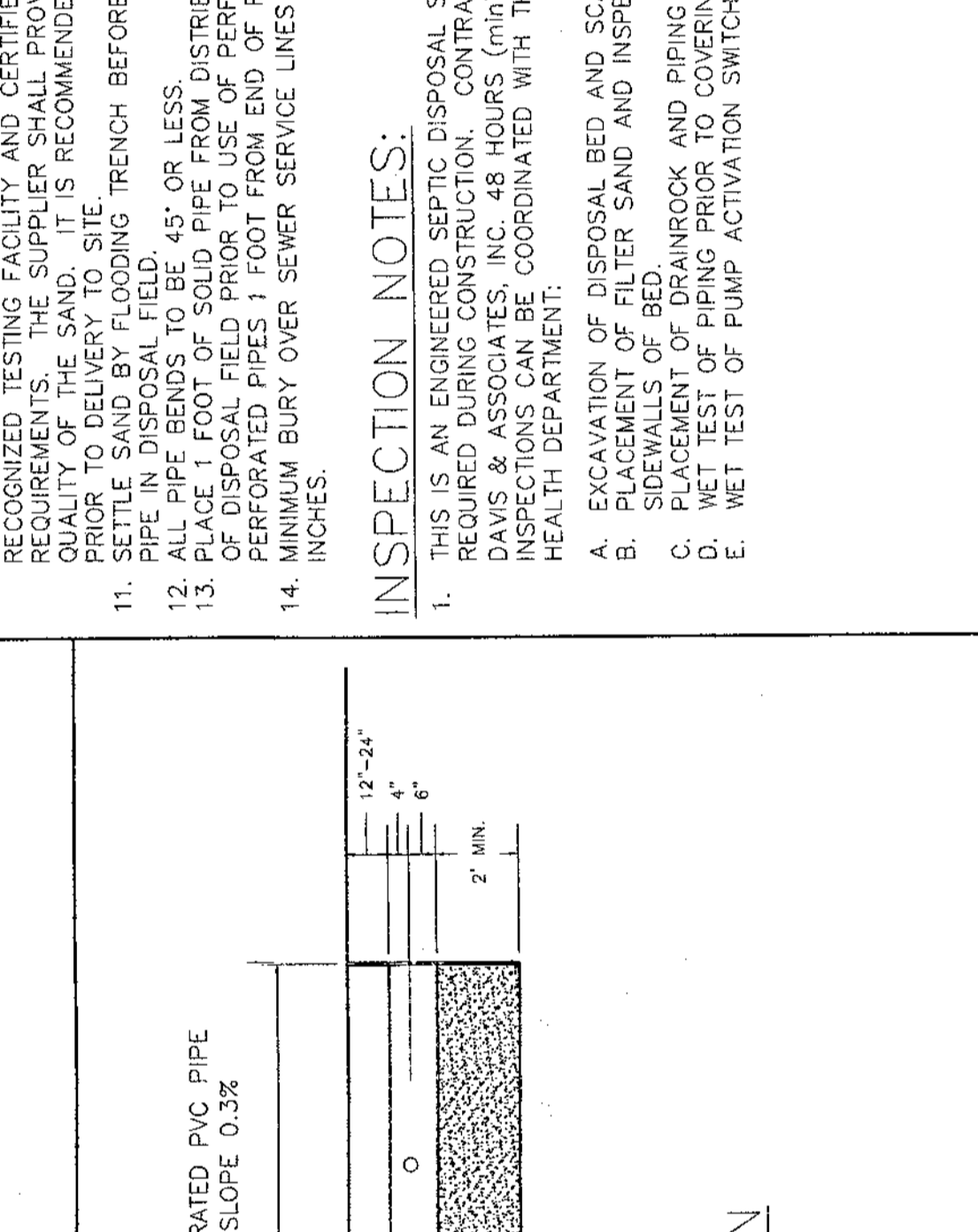
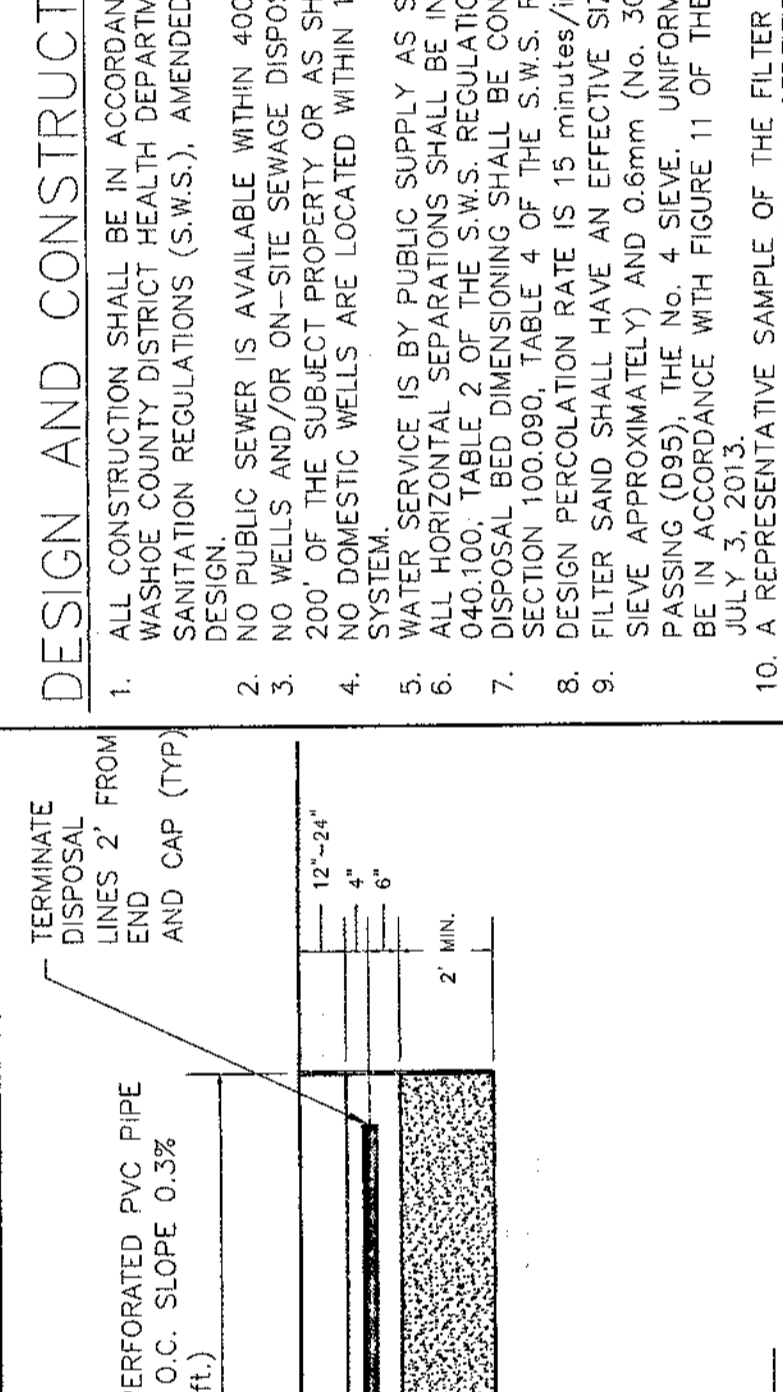
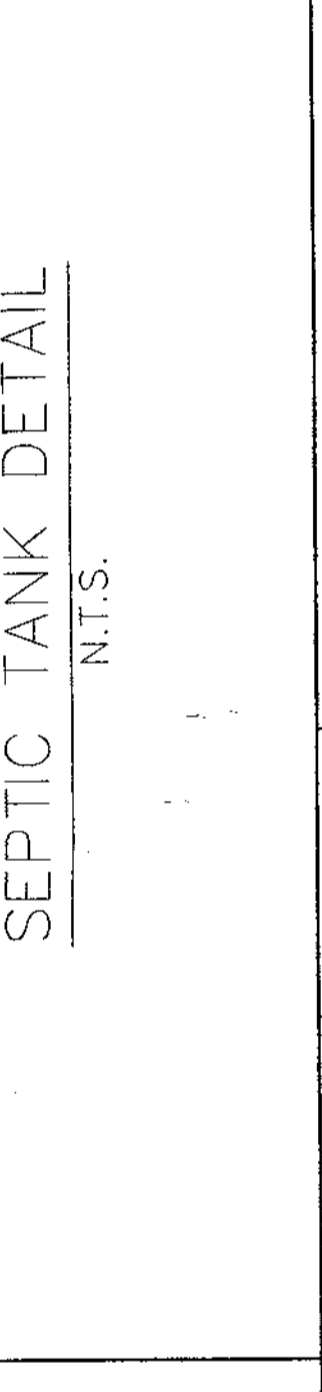

LOT INFORMATION:  
 ADDRESS: 15425 PINION DRIVE, RENO, WASHOE COUNTY, NEVADA 89521  
 ASSESSOR'S PARCEL: 017-123-05  
 SECTION: PORTION OF THE SW 1/4 OF THE NE 1/4 OF SECTION 34, T18N, R20E  
 LOT SIZE: 43750 SQUARE FEET (1.004 ACRE)

LEGAL OWNER:  
 MICHAEL & RHONDA FRITZ  
 P.O. BOX 17043  
 RENO, NV 89511  
 (775) 843-2802  
 mfriz518@gmail.com

DESIGN ENGINEER:  
 CHAD E. CARNES P.E.  
 MARVIN E. DAVIS & ASSOCIATES, INC.  
 P.O. BOX 18449  
 RENO, NEVADA 89511  
 (775) 997-3862

BY	App'D
REV.	DATE

**Marvin E. Davis & Associates, Inc.**  
 CONSULTING CIVIL ENGINEERS  
 P.O. Box 18449  
 Reno, Nevada 89511  
 TEL (775)853-9100  
 FAX (775)853-9199

**VARIANCE APPLICATION FOR:**  
**FRITZ RESIDENCE**  
**15425 PINION DRIVE**  
**APN: 017-123-05**  
**ON-SITE DISPOSAL PLAN**  
 WASHOE COUNTY  
 NEVADA

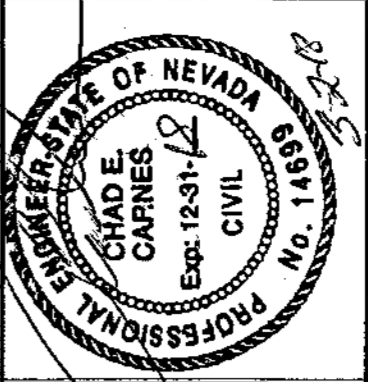

DATE: 03/02/18  
 JOB NUMBER: 17104.001  
 DESIGNED BY: CEC  
 DRAWN BY: CEC  
 CHECKED BY: CEC

**SHEET**  
**SD1**

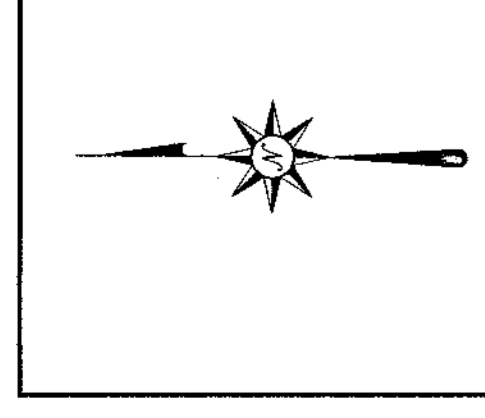
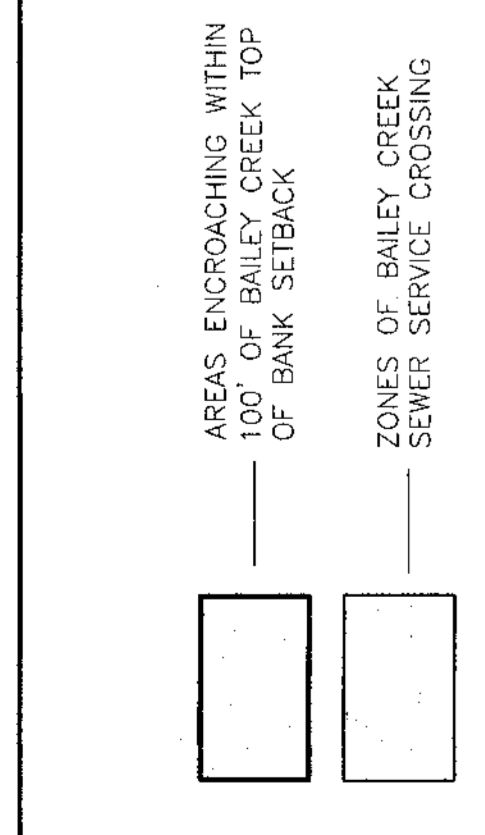
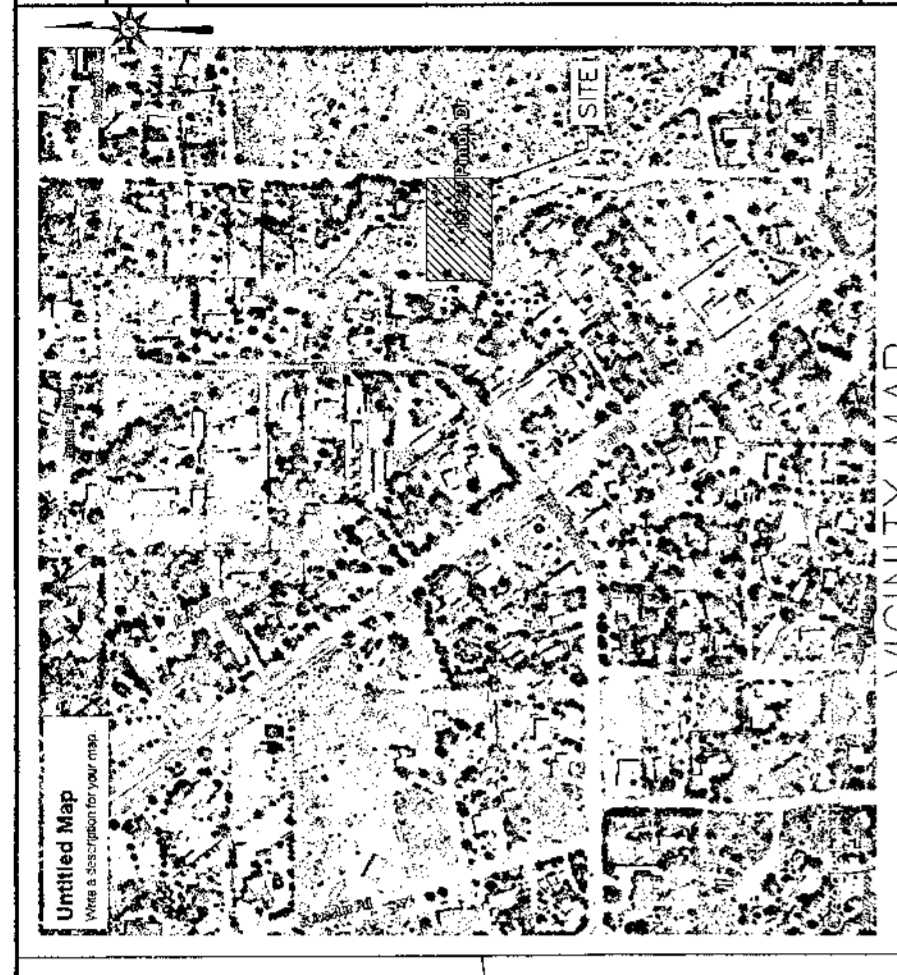
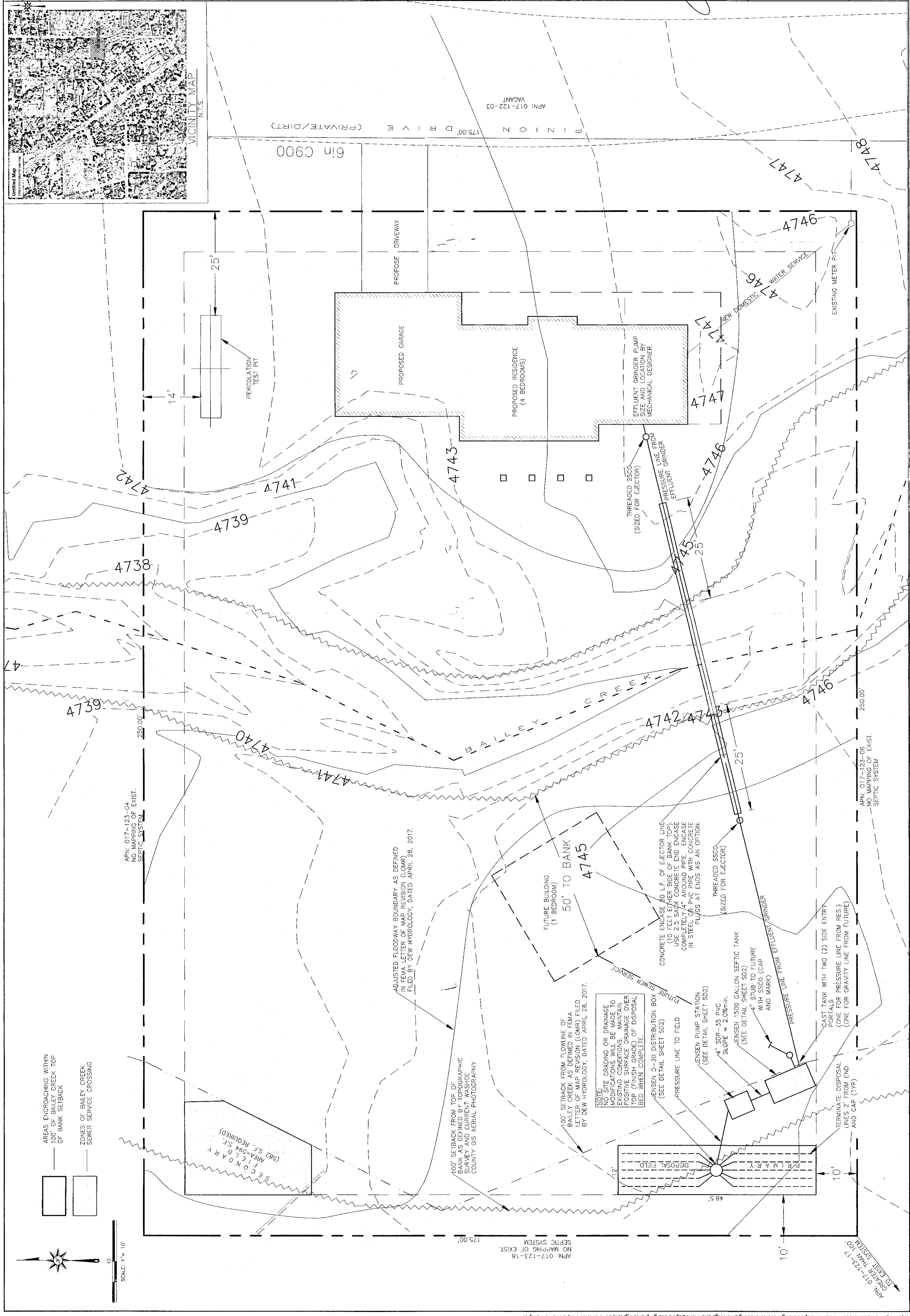

APN: 017-123-04  
 NO. MAPPING OF EXIST.  
 SEPTIC SYSTEM

ADJUSTED FLOODWAY BOUNDARY AS DEFINED  
 IN FEMA LETTER OF MAP REVISION (LOMR)  
 FILED BY DEW HYDROLOGY, DATED APRIL 28, 2017.

100' SETBACK FROM TOP OF  
 BAILEY CREEK AS DEFINED BY TOPOGRAPHIC  
 SURVEY AND CURRENT WASHOE  
 COUNTY GIS AERIAL PHOTOGRAPHY

100' SETBACK FROM FLOWLINE OF  
 BAILEY CREEK AS DEFINED IN FEMA  
 LETTER OF MAP REVISION (LOMR) FILED  
 BY DEW HYDROLOGY, DATED APRIL 28, 2017.

**NOTE:**  
 NO SITE GRADING OR DRAINAGE  
 MODIFICATIONS WILL BE MADE TO  
 EXISTING CONDITIONS. MAINTAIN  
 POSITIVE SURFACE DRAINAGE OVER  
 TOP (FINISH GRADE) OF DISPOSAL  
 BED WHEN COMPLETE.

CONCRETE ENCASE 60 L.F. OF EJECTOR LINE  
 (12 FEET EACH SIDE OF BANK TOP).  
 USE 2.5" SACK CONCRETE. END ENCASE  
 COMPLETELY 4" AROUND PIPE WITH CONCRETE  
 IN STEEL OR PVC PIPE WITH CONCRETE  
 PLUGS AT ENDS AS AN OPTION.

JENSEN PUMP STATION  
 (SEE DETAIL SHEET SD2)  
 4" SDR-35 PVC  
 SLOPE = 2.02%/min.

JENSEN 1500 GALLON SEPTIC TANK  
 (SEE DETAIL SHEET SD2)  
 4" STUB TO FUTURE  
 WITH SSCO (CAP  
 AND MARK)

CAST TANK WITH TWO (2) SIDE ENTRY  
 PORTALS  
 (ONE FOR PRESSURE LINE FROM RES.)  
 (ONE FOR GRAVITY LINE FROM FUTURE)

TERMINATE DISPOSAL  
 LINES 2' FROM END  
 AND CAP (TYP)

APN: 017-123-06  
 NO. MAPPING OF EXIST.  
 SEPTIC SYSTEM

APN: 017-123-17  
 TO EXIST. TANK 100'

APN 017-123-05



APN 017-123-05  
with floodway shown



## English, James

---

**From:** Kelly, David A  
**Sent:** Thursday, March 22, 2018 3:27 PM  
**To:** English, James  
**Subject:** FW: Parcel 017-123-05. Is this really a buildable lot?

This is the variance package. I have not responded to Ms. Armstrong.

### David Kelly, REHS

Environmental Health Specialist | Environmental Health | Washoe County Health District  
[dakelly@washoecounty.us](mailto:dakelly@washoecounty.us) | O: (775) 328-2630 | 1001 E. Ninth St., Bldg. B, Reno, NV 89512

WASHOE COUNTY  
HEALTH DISTRICT



ENHANCING QUALITY OF LIFE

Public Health

 Please consider the environment before printing this e-mail.

---

**From:** D. Armstrong [mailto:[deb.armstrong@yahoo.com](mailto:deb.armstrong@yahoo.com)]  
**Sent:** Thursday, March 22, 2018 3:11 PM  
**To:** Corbridge, Kimble; Kelly, David A  
**Subject:** Parcel 017-123-05. Is this really a buildable lot?

I understand that the owner of this property wants to run live sewage across the creek. I'm baffled about how that engineering will work. Thought you'd like to see the "creek" today... Are you sure this is a buildable lot? Maybe this guy needs to sue his realtor for selling him something that really isn't possible. ....

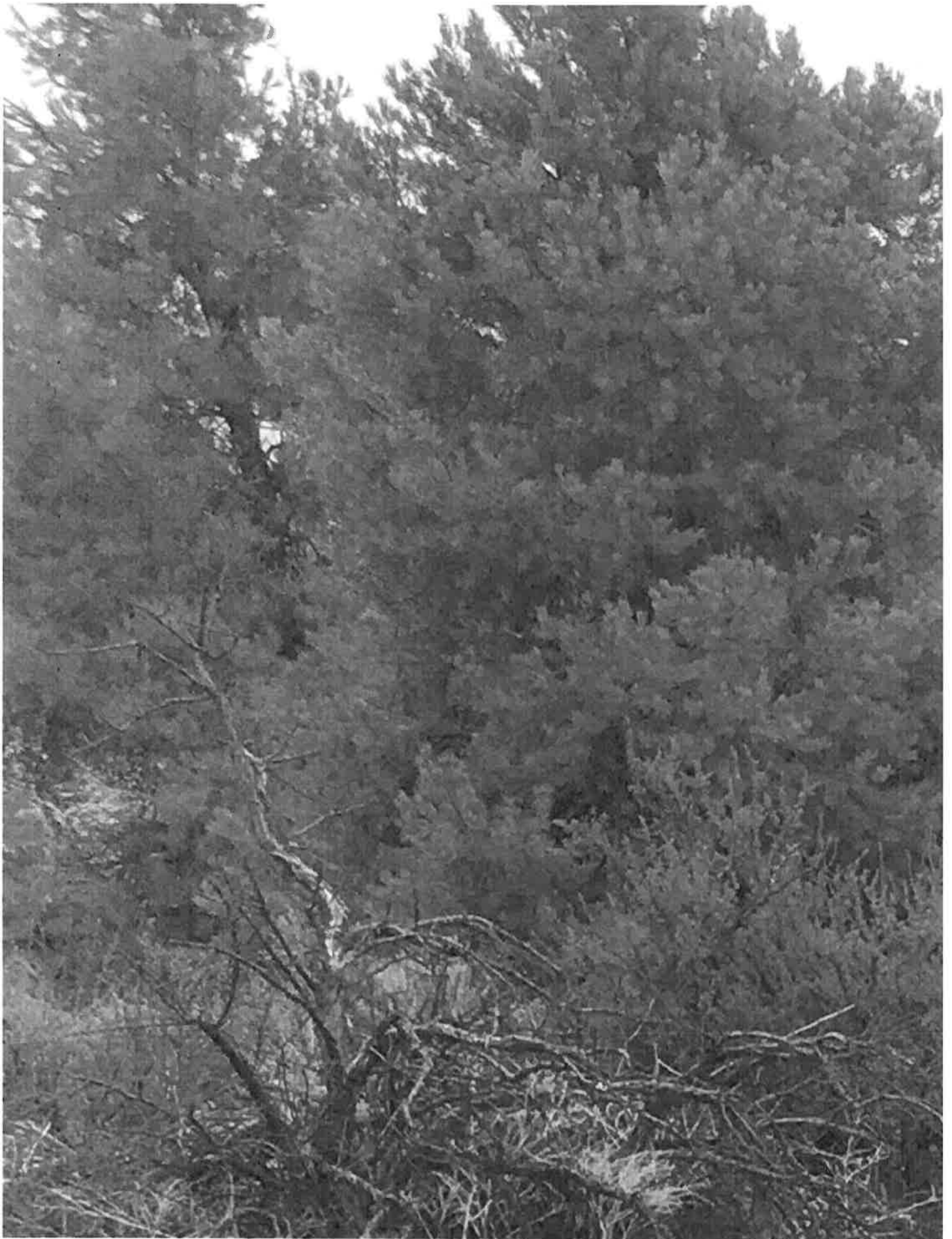











# Federal Emergency Management Agency

Washington, D.C. 20472

March 20, 2018

CERTIFIED MAIL  
RETURN RECEIPT REQUESTED

The Honorable Marsha Berkgigler  
Chair, Board of Commissioners  
Washoe County  
1001 East 9th Street  
Reno, NV 89512

IN REPLY REFER TO:

Case No.: 17-09-1858P  
Community Name: Washoe County, NV  
Community No.: 320019  
Effective Date of  
This Revision: **August 1, 2018**

Dear Ms. Berkgigler:

The Flood Insurance Study Report and Flood Insurance Rate Map for your community have been revised by this Letter of Map Revision (LOMR). Please use the enclosed annotated map panels revised by this LOMR for floodplain management purposes and for all flood insurance policies and renewals issued in your community.

Additional documents are enclosed which provide information regarding this LOMR. Please see the List of Enclosures below to determine which documents are included. Other attachments specific to this request may be included as referenced in the Determination Document. If you have any questions regarding floodplain management regulations for your community or the National Flood Insurance Program (NFIP) in general, please contact the Consultation Coordination Officer for your community. If you have any technical questions regarding this LOMR, please contact the Director, Mitigation Division of the Department of Homeland Security's Federal Emergency Management Agency (FEMA) in Oakland, California, at (510) 627-7175, or the FEMA Map Information eXchange (FMIX) toll free at 1-877-336-2627 (1-877-FEMA MAP). Additional information about the NFIP is available on our website at <http://www.fema.gov/business/nfip>.

Sincerely,

Patrick "Rick" F. Sacbibit, P.E., Branch Chief  
Engineering Services Branch  
Federal Insurance and Mitigation Administration

List of Enclosures:

Letter of Map Revision Determination Document  
Annotated Flood Insurance Rate Map  
Annotated Flood Insurance Study Report

cc: Mr. Kimble O. Corbridge, P.E., CFM  
Assistant Public Works Director  
Washoe County

Mr. David Westhoff, P.E.  
Principal Hydrologist  
DEW Hydrology



**Federal Emergency Management Agency**  
Washington, D.C. 20472

**LETTER OF MAP REVISION  
DETERMINATION DOCUMENT**

COMMUNITY AND REVISION INFORMATION		PROJECT DESCRIPTION	BASIS OF REQUEST
COMMUNITY	Washoe County Nevada (Unincorporated Areas)	CULVERT	FLOODWAY HYDRAULIC ANALYSIS UPDATED TOPOGRAPHIC DATA
	COMMUNITY NO.: 320019		
IDENTIFIER	Fritz Parcel	APPROXIMATE LATITUDE & LONGITUDE: 39.383, -119.720 SOURCE: USGS QUADRANGLE      DATUM: NAD 83	
ANNOTATED MAPPING ENCLOSURES		ANNOTATED STUDY ENCLOSURES	
TYPE: FIRM*      NO.: 32031C3263G      DATE: March 16, 2009 TYPE: FIRM*      NO.: 32031C3264G      DATE: March 16, 2009		DATE OF EFFECTIVE FLOOD INSURANCE STUDY REPORT: June 18, 2013 PROFILE: 04P FLOODWAY DATA TABLE: 7	

Enclosures reflect changes to flooding sources affected by this revision.  
\* FIRM - Flood Insurance Rate Map

**FLOODING SOURCE(S) & REVISED REACH(ES)**

Bailey Canyon Creek - From approximately 510 feet downstream of Kivett Lane to approximately 205 feet upstream of Pinion Drive

**SUMMARY OF REVISIONS**

Flooding Source	Effective Flooding	Revised Flooding	Increases	Decreases
Bailey Canyon Creek	Zone AE	Zone AE	YES	YES
	BFEs	BFEs	YES	YES
	Floodway	Floodway	NO	YES

\* BFEs - Base Flood Elevations

**DETERMINATION**

This document provides the determination from the Department of Homeland Security's Federal Emergency Management Agency (FEMA) regarding a request for a Letter of Map Revision (LOMR) for the area described above. Using the information submitted, we have determined that a revision to the flood hazards depicted in the Flood Insurance Study (FIS) report and/or National Flood Insurance Program (NFIP) map is warranted. This document revises the effective NFIP map, as indicated in the attached documentation. Please use the enclosed annotated map panels revised by this LOMR for floodplain management purposes and for all flood insurance policies and renewals in your community.

This determination is based on the flood data presently available. The enclosed documents provide additional information regarding this determination. If you have any questions about this document, please contact the FEMA Map Information eXchange toll free at 1-877-336-2627 (1-877-FEMA MAP) or by letter addressed to the LOMC Clearinghouse, 3601 Eisenhower Avenue, Suite 500, Alexandria, VA 22304-6426. Additional Information about the NFIP is available on our website at <http://www.fema.gov/nfip>.

Patrick "Rick" F. Sacbibit, P.E., Branch Chief  
Engineering Services Branch  
Federal Insurance and Mitigation Administration



Federal Emergency Management Agency  
Washington, D.C. 20472

**LETTER OF MAP REVISION  
DETERMINATION DOCUMENT (CONTINUED)**

**COMMUNITY INFORMATION**

**APPLICABLE NFIP REGULATIONS/COMMUNITY OBLIGATION**

We have made this determination pursuant to Section 206 of the Flood Disaster Protection Act of 1973 (P.L. 93-234) and in accordance with the National Flood Insurance Act of 1968, as amended (Title XIII of the Housing and Urban Development Act of 1968, P.L. 90-448), 42 U.S.C. 4001-4128, and 44 CFR Part 65. Pursuant to Section 1361 of the National Flood Insurance Act of 1968, as amended, communities participating in the NFIP are required to adopt and enforce floodplain management regulations that meet or exceed NFIP criteria. These criteria, including adoption of the FIS report and FIRM, and the modifications made by this LOMR, are the minimum requirements for continued NFIP participation and do not supersede more stringent State/Commonwealth or local requirements to which the regulations apply.

We provide the floodway designation to your community as a tool to regulate floodplain development. Therefore, the floodway revision we have described in this letter, while acceptable to us, must also be acceptable to your community and adopted by appropriate community action, as specified in Paragraph 60.3(d) of the NFIP regulations.

NFIP regulations Subparagraph 60.3(b)(7) requires communities to ensure that the flood-carrying capacity within the altered or relocated portion of any watercourse is maintained. This provision is incorporated into your community's existing floodplain management ordinances; therefore, responsibility for maintenance of the altered or relocated watercourse, including any related appurtenances such as bridges, culverts, and other drainage structures, rests with your community. We may request that your community submit a description and schedule of maintenance activities necessary to ensure this requirement.

**COMMUNITY REMINDERS**

We based this determination on the 1-percent-annual-chance flood discharges computed in the FIS for your community without considering subsequent changes in watershed characteristics that could increase flood discharges. Future development of projects upstream could cause increased flood discharges, which could cause increased flood hazards. A comprehensive restudy of your community's flood hazards would consider the cumulative effects of development on flood discharges subsequent to the publication of the FIS report for your community and could, therefore, establish greater flood hazards in this area.

Your community must regulate all proposed floodplain development and ensure that permits required by Federal and/or State/Commonwealth law have been obtained. State/Commonwealth or community officials, based on knowledge of local conditions and in the interest of safety, may set higher standards for construction or may limit development in floodplain areas. If your State/Commonwealth or community has adopted more restrictive or comprehensive floodplain management criteria, those criteria take precedence over the minimum NFIP requirements.

This determination is based on the flood data presently available. The enclosed documents provide additional information regarding this determination. If you have any questions about this document, please contact the FEMA Map Information eXchange toll free at 1-877-336-2627 (1-877-FEMA MAP) or by letter addressed to the LOMC Clearinghouse, 3601 Eisenhower Avenue, Suite 500, Alexandria, VA 22304-6426. Additional Information about the NFIP is available on our website at <http://www.fema.gov/nfip>.

Patrick "Rick" F. Sachbit, P.E., Branch Chief  
Engineering Services Branch  
Federal Insurance and Mitigation Administration



Federal Emergency Management Agency  
Washington, D.C. 20472

**LETTER OF MAP REVISION  
DETERMINATION DOCUMENT (CONTINUED)**

We will not print and distribute this LOMR to primary users, such as local insurance agents or mortgage lenders; instead, the community will serve as a repository for the new data. We encourage you to disseminate the information in this LOMR by preparing a news release for publication in your community's newspaper that describes the revision and explains how your community will provide the data and help interpret the NFIP maps. In that way, interested persons, such as property owners, insurance agents, and mortgage lenders, can benefit from the information.

We have designated a Consultation Coordination Officer (CCO) to assist your community. The CCO will be the primary liaison between your community and FEMA. For information regarding your CCO, please contact:

Mr. Jeffrey D. Lusk  
Director, Mitigation Division  
Federal Emergency Management Agency, Region IX  
1111 Broadway Street, Suite 1200  
Oakland, CA 94607-4052  
(510) 627-7175

**STATUS OF THE COMMUNITY NFIP MAPS**

We will not physically revise and republish the FIRM and FIS report for your community to reflect the modifications made by this LOMR at this time. When changes to the previously cited FIRM panel(s) and FIS report warrant physical revision and republication in the future, we will incorporate the modifications made by this LOMR at that time.

This determination is based on the flood data presently available. The enclosed documents provide additional information regarding this determination. If you have any questions about this document, please contact the FEMA Map Information eXchange toll free at 1-877-336-2627 (1-877-FEMA MAP) or by letter addressed to the LOMC Clearinghouse, 3601 Eisenhower Avenue, Suite 500, Alexandria, VA 22304-6426. Additional information about the NFIP is available on our website at <http://www.fema.gov/nfip>.

A handwritten signature in black ink, appearing to read "Rick F. Sacbibit".

Patrick "Rick" F. Sacbibit, P.E., Branch Chief  
Engineering Services Branch  
Federal Insurance and Mitigation Administration



# Federal Emergency Management Agency

Washington, D.C. 20472

## LETTER OF MAP REVISION DETERMINATION DOCUMENT (CONTINUED)

### PUBLIC NOTIFICATION OF REVISION

A notice of changes will be published in the *Federal Register*. This information also will be published in your local newspaper on or about the dates listed below, and through FEMA's Flood Hazard Mapping website at [https://www.floodmaps.fema.gov/thm/bfc\\_status/bfe\\_main.asp](https://www.floodmaps.fema.gov/thm/bfc_status/bfe_main.asp)

#### LOCAL NEWSPAPER

Name: *Reno Gazette-Journal*  
Date: March 27, 2018 and April 3, 2018

Within 90 days of the second publication in the local newspaper, any interested party may request that we reconsider this determination. Any request for reconsideration must be based on scientific or technical data. Therefore, this letter will be effective only after the 90-day appeal period has elapsed and we have resolved any appeals that we receive during this appeal period. Until this LOMR is effective, the revised flood hazard determination presented in this LOMR may be changed.

This determination is based on the flood data presently available. The enclosed documents provide additional information regarding this determination. If you have any questions about this document, please contact the FEMA Map Information eXchange toll free at 1-877-336-2627 (1-877-FEMA MAP) or by letter addressed to the LOMC Clearinghouse, 3601 Eisenhower Avenue, Suite 500, Alexandria, VA 22304-6426. Additional Information about the NFIP is available on our website at <http://www.fema.gov/nfip>.

A handwritten signature in black ink, appearing to read "Rick F. Sacbbit".

Patrick "Rick" F. Sacbbit, P.E., Branch Chief  
Engineering Services Branch  
Federal Insurance and Mitigation Administration



FLOODING SOURCE		FLOODWAY				BASE FLOOD WATER-SURFACE ELEVATION (FEET NAVD)			
CROSS SECTION	DISTANCE <sup>1</sup>	WIDTH (FEET)	SECTION AREA (SQUARE FEET)	MEAN VELOCITY (FEET PER SECOND)	REGULATORY	WITHOUT FLOODWAY	WITH FLOODWAY	INCREASE	
Bailey Canyon Creek									
A	385	63	127	8.9	4,561.5	4,561.5	4,561.5	0.0	
B	907	139	174	6.5	4,566.9	4,566.9	4,566.9	0.0	
C	1,889	425	382	6.1	4,583.3	4,583.3	4,583.3	0.0	
D	2,686	93	163	8.7	4,598.2	4,598.2	4,598.2	0.0	
E	4,790	93	153	7.4	4,626.9	4,626.9	4,626.9	0.0	
F	6,203	167	270	4.2	4,653.5	4,653.5	4,653.5	0.0	
G	6,895	47	124	9.9	4,671.1	4,671.1	4,671.1	0.0	
H	8,288	227	243	4.6	4,712.0	4,712.0	4,712.0	0.0	
I	9,761	144	177	6.4	4,746.7	4,746.7	4,746.7	0.0	
J	10,136	245	156	7.2	4,756.4	4,756.4	4,756.4	0.0	
Revised Data							REVISED TO		

<sup>1</sup>Feet above confluence with Steamboat Creek

REFLECT LOMR

EFFECTIVE: August 1, 2018

FEDERAL EMERGENCY MANAGEMENT AGENCY

WASHOE COUNTY, NV  
AND INCORPORATED AREAS

TABLE 7

FLOODWAY DATA

BAILEY CANYON CREEK

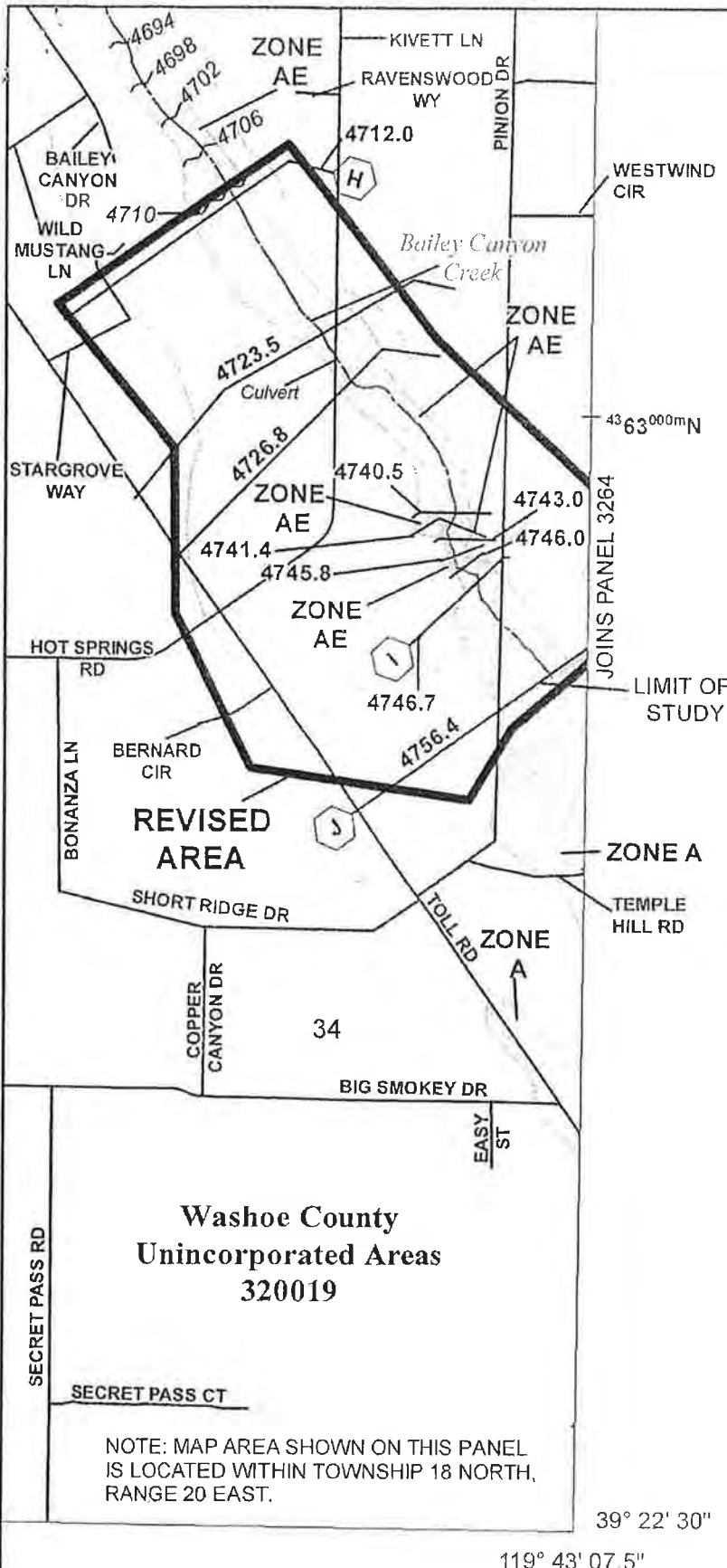

**Washoe County  
Unincorporated Areas  
320019**

SECRET PASS CT

NOTE: MAP AREA SHOWN ON THIS PANEL IS LOCATED WITHIN TOWNSHIP 18 NORTH, RANGE 20 EAST.

39° 22' 30"  
119° 43' 07.5"

**SPECIAL FLOOD HAZARD AREAS**

- Without Base Flood Elevation (BFE)  
*Zones A, V, A99*
- With BFE or Depth *Zones AE, AO, AH, VE, AP*
- Regulatory Floodway
- 0.2% Annual Chance Flood Hazard, Areas of 1% annual chance flood with average depth less than one foot or with drainage areas of less than one square mile *Zone X*
- Future Conditions 1% Annual Chance Flood Hazard *Zone X*

**OTHER AREAS OF FLOOD HAZARD**

- Area with Reduced Flood Risk due to Levee  
See Notes, *Zone X*

**SCALE**

Map Projection:  
NAD 1983 StatePlane Nevada West FIPS 2703 Feet  
Western Hemisphere, Vertical Datum: NAVD 88

1 inch = 500 feet      1:6,000

0 250 500 1,000 Feet  
0 75 150 300 Meters

**FEMA**  
National Flood Insurance Program

**NATIONAL FLOOD INSURANCE PROGRAM  
FLOOD INSURANCE RATE MAP**

**WASHOE COUNTY, NEVADA**  
And Incorporated Areas

**PANEL 3263 of 3475**

COMMUNITY	NUMBER	PANEL	SUFFIX
RENO, CITY OF	320020	3263	G
WASHOE COUNTY	320019	3263	G

**REVISED TO REFLECT LOMR  
EFFECTIVE: August 1, 2018**

REVISION NUMBER  
**1110**

MAP NUMBER  
32031C3263G

EFFECTIVE DATE  
MARCH 16, 2009

NOTE: MAP AREA SHOWN ON THIS PANEL IS LOCATED WITHIN TOWNSHIP 18 NORTH, RANGE 20 EAST.

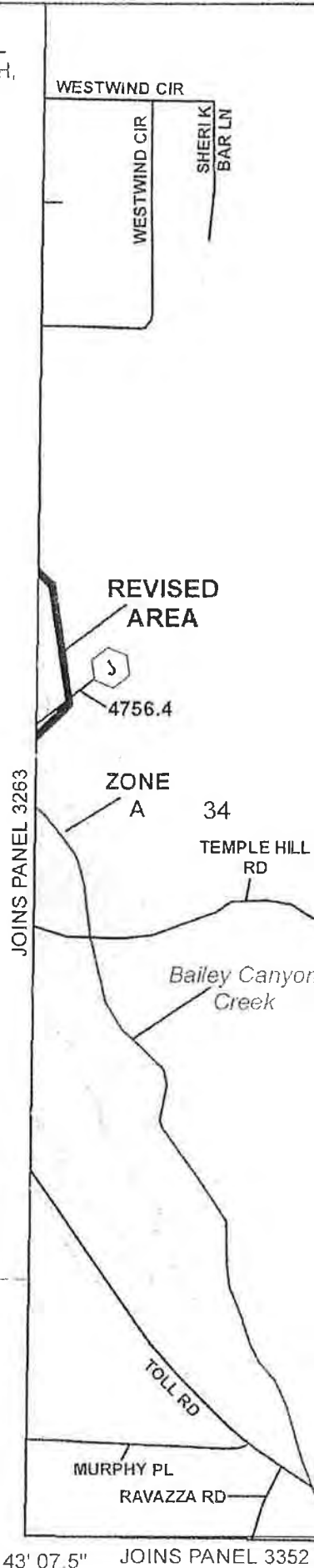

Washoe County  
Unincorporated Areas  
320019

**SPECIAL FLOOD HAZARD AREAS**

- Without Base Flood Elevation (BFE)  
Zone A, V, A99  
With BFE or Depth Zone AE, AO, AH, V1, AR
- Regulatory Floodway
- 0.2% Annual Chance Flood Hazard, Areas of 1% annual chance flood with average depth less than one foot or with drainage areas of less than one square mile Zone X
- Future Conditions 1% Annual Chance Flood Hazard Zone X
- Area with Reduced Flood Risk due to Levee See Notes. Zone X

**OTHER AREAS OF FLOOD HAZARD**

**SCALE**

Map Projection:  
NAD 83/93 StatePlane Nevada West FIPS 2703 Feet  
Western Hemisphere, Vertical Datum: NAVD 83

1 inch = 500 feet 1:6,000

0 250 500 1,000 Feet  
0 75 150 300 Meters

**FEMA**  
National Flood Insurance Program

NATIONAL FLOOD INSURANCE PROGRAM  
FLOOD INSURANCE RATE MAP  
WASHOE COUNTY, NEVADA  
And Incorporated Areas

PANEL **3264** OF **3475**

COMMUNITY WASHOE COUNTY NUMBER 320019 PANEL 3264 SUFFIX G

REVISED TO REFLECT LOMR EFFECTIVE: August 1, 2018

VERSION NUMBER 1.1.1.0  
MAP NUMBER 32031C3264G  
EFFECTIVE DATE MARCH 16, 2009

4,760  
4,750  
4,740  
4,730  
4,720  
4,710  
4,700

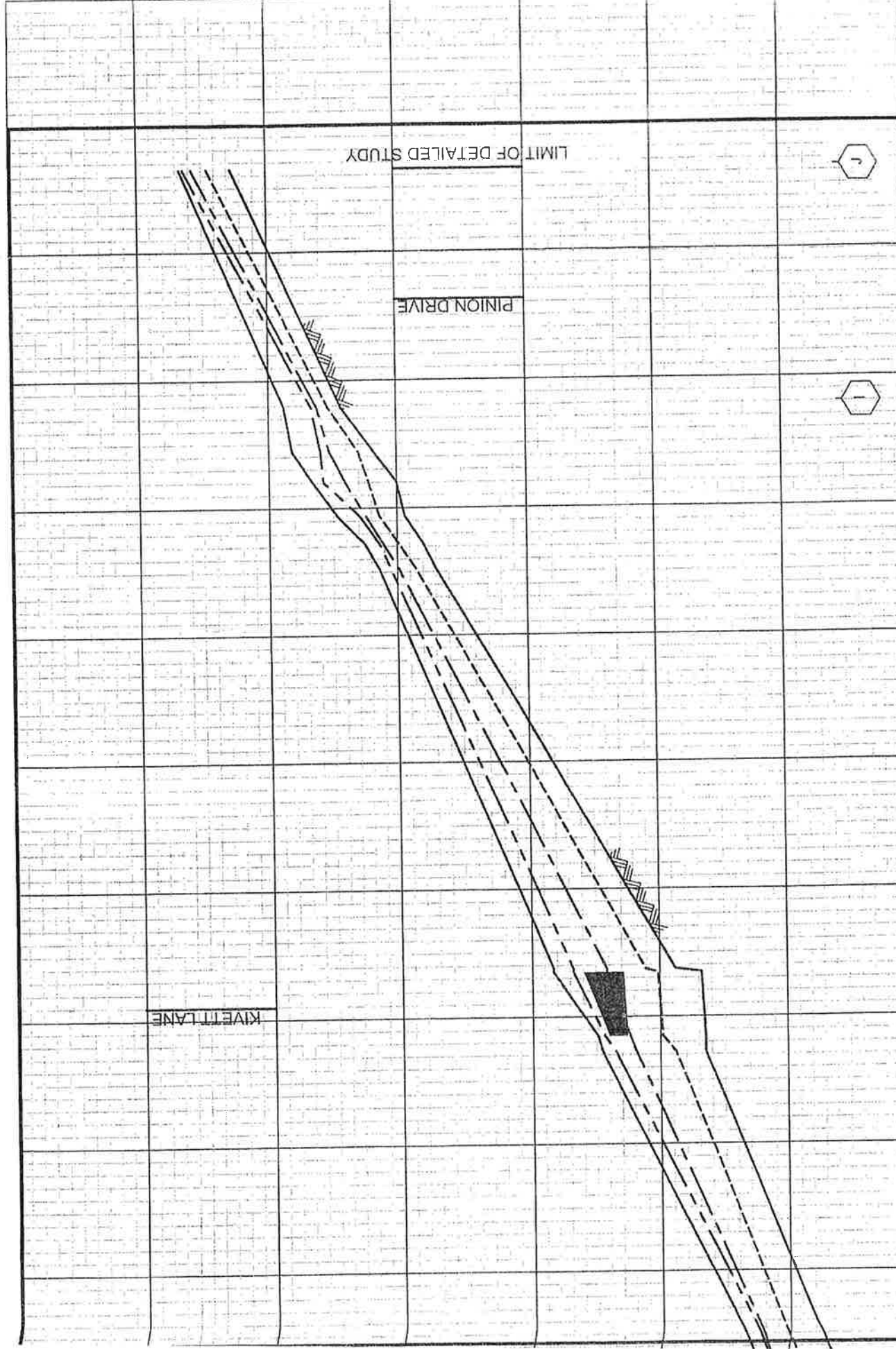

LEGEND

- 0.2% ANNUAL CHANCE FLOOD
- 1% ANNUAL CHANCE FLOOD

KIVETT LANE

PINION DRIVE

LIMIT OF DETAILED STUDY

**SEWAGE, WASTEWATER, AND SANITATION HEARING BOARD  
MEETING MINUTES**

**Members**

Ronald J. Anderson, P.E., Chair  
Matthew Buehler  
Vonnie Fundin  
Nick Vestbie, P.E.  
Matt Smith – Alternate  
Ray Pezonella, P.E - Alternate

**Monday, May 7, 2018**

**6:00 p.m.**

**Washoe County Administration Complex  
Health District South Conference Room  
1001 East Ninth Street  
Reno, NV**

---

**6:00 p.m.**

**1. \*Roll Call and Determination of Quorum**

Chair Anderson called the meeting to order at 6:04 p.m.

The following members and staff were present:

Members present: Ronald J. Anderson, P.E., Chair  
Matthew Buehler  
Vonnie Fundin  
Nick Vestbie, P.E.

Members absent: Matt Smith - Alternate  
Ray Pezonella, P.E - Alternate

**Ms. Rogers verified a quorum was present.**

**2. \*Pledge of Allegiance**

Those present pledged allegiance to the flag.

**3. \*Public Comment**

Chair Anderson thanked the newly appointed members of the Sewage, Wastewater and Sanitation (SWS) Board for offering to serve the community and welcomed those present at the meeting.

Chair Anderson requested a letter of thanks be sent to the two previous SWS Board Members for their service to the community. Mr. English agreed to do so.

**Chair Anderson closed the public comment period.**

**4. Approval of Agenda**

May 7, 2018

Mr. Buehler moved to accept the agenda for the May 7, 2018, Sewage, Wastewater and Sanitation Hearing Board meeting. Mr. Vestbie seconded the motion which was approved four in favor and none against.

## 5. Approval of Draft Minutes

June 5, 2017

Mr. Buehler moved to accept the minutes of the June 5, 2017 Sewage, Wastewater, & Sanitation Board meeting as written. Mr. Fundin seconded the motion which was approved four in favor and none against.

## 6. Public Hearing to determine whether or not to recommend approval to the District Board of Health for a variance for APN 017-123-05 owned by Mike Fritz for Section 040.080 and Table 2 "Watercourses" including Sub-Script (4) of the Regulations of the Washoe County District Board of Health Governing Sewage, Wastewater, and Sanitation.

Staff Representative: James English

Mr. Mike Fritz  
15425 Pinion Drive  
Reno, NV 89521  
Assessor's Parcel Number 017-123-05

### Chair Anderson opened the Public Hearing.

Mr. English stated that they were present regarding a variance application for Mr. Mike Fritz at 15425 Pinion Dr., explaining the variance is requested due to set-back issues on the parcel. He informed that Bailey Creek runs through the property and is the source of the set-back issues, specifically that the only suitable location for the septic system would potentially require a creek crossing. Also, he informed that Environmental Health Services (EHS) has always considered the one hundred foot set-back to be measured from the break in the bank of a watercourse when it is a named water source.

Mr. English informed that the applicant worked with an engineer to develop what they believe to be the best design possible to allow both a septic system and future repair field on the lot. He stated that the plan was included in their packets.

Mr. English informed that an EHS team had gone through the regulations to prepare a list of questions that the Board would need to address concerning this variance request, and that the team had answers prepared for those questions.

Mr. English stated that a test trench had been dug on the property and no ground water was present at a depth of thirteen feet which would allow for standard trenches if set-backs could easily be met. He informed EHS recommended the option of an engineered system or sand filter bed to be more protective of ground water.

Mr. English stated that the application was presented with plans for an at-grade sand filter bed which allows for an additional five feet more of protection between the system and ground water.

Mr. English stated that EHS staff believes that this is the most conservative and protective design for public health for the parcel, with the only possible issue in staff's opinion being the location of the sewer line crossing Bailey Creek and the potential for water contamination should the line fail in a flood situation.

Mr. English informed that EHS staff sees no other reasonable alternatives to this plan, other than to make this a raised filter bed, but noted that ground water is not the issue on this lot.

Information on the flood zone at the site was discussed.

Mr. Carnes informed that in their site visits they had not seen evidence of overbanking, and that photos of last year's flood event showed the creek to be running no more than a foot above normal flow.

Mr. Carnes stated there were two options on the plan, informing their original option would be to have the line encased in concrete.

Mr. Carnes informed that the creek bottom had not been eroded much by this last storm event and opined there isn't a risk with the concrete encased or sleeved design, noting the reinforcement would extend twenty-five feet past the bank line.

Mr. Vestbie asked if the conduit would be supported all the way across or in the middle. Mr. Carnes confirmed that it would.

Mr. Carnes informed that the flow grinder will be sized by the owner's mechanical designer and noted that it had not been purchased yet. He stated that the pressure line will be designed to drain back to the grinder pump and the size of the effluent grinder line will be based on the head loss for the unit he purchases. He informed that he would work with the owner and the mechanical designer on those decisions.

Chair Anderson opined that the design looked good, but needed clarification on the crossing detail and stated that a profile view of that section would have helped. He opined that there should be electrical conduit going across the creek in the same trench with the ejector line and have also it encased in concrete.

Mr. Carnes informed his design concept had the electrical in a sleeve encased in concrete in the event the electrical line had to be pulled in case of failure, and the sleeve with a protrusion plug at either end. He opined this design would have the safety of concrete encasement in a combined trench, but allow electrical repair if needed.

Mr. Buehler inquired if this design has been used before and how well do they work. Mr. Carnes stated that he had installed this design before and that others have as well, and he knows of no problems with them. Mr. Carnes stated that they do require annual maintenance which is included in the packet when the unit is purchased, and that this information will be covered with the owners.

Mr. Buehler inquired how the owner would know if the sewer line is compromised if it is encased in concrete, and would the concrete encasement hold the pressure of the line.

Mr. Carnes confirmed with Mr. Buehler that his inquiry was concerning the ejector line from the flow grinder to the septic line, and if it were to break, would there be an alarm to notify the owner. Mr. Carnes stated that the encasement would handle the pressure, and the encasement would be self-supported preventing movement of the line.

Mr. Fundin stated the system would be low pressure and Mr. Carnes agreed, and informed that it would be encased in HDPE pipe. He indicated that he would research if any sort of alarm is available for this application. Mr. Carnes informed that he had never seen a system fail of this design.

Mr. Carnes reiterated that the mechanical designer is directly involved in the specs for the ejector line so it functions with their unit with a high factor of safety, and informed that they have used this design in sensitive areas such as Lake Tahoe with the effluent station being installed on the beach and explained those projects.

Chair Anderson informed that this design is common practice.

Mr. Carnes informed that he has used Liberty pumps in similar designs and was impressed with their support and warranties.

Mr. Vestbie opined there would have to be some sort of strain criteria because of insufficient pressure, and that it could require a strain gauge. Mr. Carnes stated that he would research this request.

Mr. Buehler requested Mr. Carnes to detail the type of maintenance required on this system. Mr. Carnes informed that there would be an annual impedance check on the pumps and to assure the pit is cleaning itself, as well as the property owner will also perform a

simple telemetry check. Mr. Carnes informed that there is a warranty period and recommended replacement of the pumps, and informed that the new pumps have a relatively long life due to improved seal assemblies which preserves the bearings.

Mr. Buehler inquired if the life span on the pumps would be decades and Mr. Carnes confirmed that to be correct, stating that the key element to the pump lasting is for the head loss of the effluent line to be designed for the pumps to avoid strain on the pumps. He informed that they suggested a duplex pump as opposed to a singular and that will be what is purchased for the system.

The appropriate size of the tank in relation to the size of the dwelling was discussed. Mr. Vestbie stated that the design should be for a 1,500 gallon septic tank. Mr. Carnes directed attention to the portion of the plans that shows a 1,500 gallon tank is the size calculated in the plans.

Mr. Vestbie stated there has to be an individual tank for each structure on the plans. Mr. Kelley informed that the secondary structure is not intended to be a dwelling, but a structure with potentially one room and informed that their regulations allow for that system to be tied into the septic system providing the total number of bedrooms does not exceed six. Mr. Kelley explained that Planning designates whether it will be a structure or a dwelling according to their guidelines, and explained the parameters to the Board.

Mr. Vestbie inquired if the separate structure would require a new application and permit before it is built. Mr. Kelley confirmed that was correct, and informed that he had suggested the owner have it designed with the additional structure on the plan to assure it is done correctly. It was confirmed that the plans included the calculation for the number of bedrooms shown on the plan.

Chair Anderson inquired if Mr. Carnes had a contract for doing the inspection and testing of this system. Mr. Carnes confirmed that he would inspect the system that is included in the plans.

Mr. Carnes informed that they will be taking accurate field measurements to confirm correct placement of tanks in respect to the field and their orientation, grade, etc., to provide the finished bid, excavation, scarification, filter sand, testing of the filter sand, rock, flow test, etc., and that he would be doing these tests himself.

Chair Anderson requested there to be an as-built plan showing the profile as built. Mr. Carnes stated that there will be, and confirmed that Chair Anderson was referring to the ejector line, which was confirmed to be correct. Chair Anderson stated he wanted the as-built plan to show the electrical conduit in with the ejector line.

Chair Anderson requested the opinion of the Board for there to be geogrid fabric over the top of the bed to prevent the structure from scouring out in a flood event. He opined that it would be a nominal additional cost to the project. Mr. Vestbie agreed it to be a good suggestion, and Mr. Carnes agreed to add that to the design.

Chair Anderson informed those were his only design comments.

**Mr. Vestbie moved to approve to the District Board of Health for a variance for APN 017-123-05 owned by Mike Fritz for Section 040.080 and Table 2 “Watercourses” including Sub-Script (4) of the Regulations of the Washoe County District Board of Health Governing Sewage, Wastewater, and Sanitation as designed with the following conditions:**

- 1. Addition of the geogrid fabric over the filter bed,**
- 2. The electrical line sleeved in conduit, and**
- 3. Show/provide a cross section profile view of creek crossing to WCHD.**



**Mr. Fundin seconded the motion which was approved four in favor and none against.**

**6. \*Public Comment**

As there was no one wishing to speak, Chair Anderson closed the public comment period.

**7. Adjournment**

At 6:37 p.m., Chair Anderson adjourned the meeting.

---

Respectfully submitted,

---

James English, Environmental Health Specialist Supervisor  
Secretary to the Sewage, Wastewater and Sanitation Board

---

Laura Rogers, Administrative Secretary  
Recording Secretary

DD	NA	___
DHO	___	KD
DA	NA	___
Risk	NA	___

**STAFF REPORT**  
**BOARD MEETING DATE: May 24, 2018**

**TO:** District Board of Health  
**FROM:** Anna Heenan, Administrative Health Services Officer  
 328-2417, [aheenan@washoecounty.us](mailto:aheenan@washoecounty.us)  
**SUBJECT:** Acknowledge receipt of the Health Fund Financial Review for April, Fiscal Year 2018

**SUMMARY**

The ten months of fiscal year 2018, (FY18) ended with a cash balance of \$5,991,807. Total revenues of \$19,306,621 were 84.4% of budget and an increase of \$1,779,611 over April FY17. The expenditures totaled \$18,060,907 or 76.3% of budget and up \$865,116 compared to April FY17.

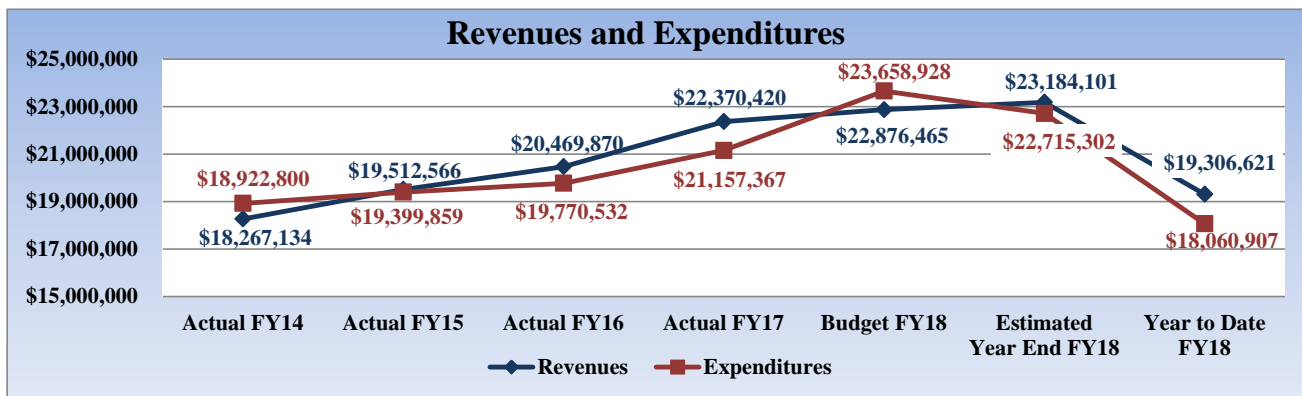

**District Health Strategic Objective supported by this item:** Financial Stability: Enable the Health District to make long-term commitments in areas that will positively impact the community’s health by growing reliable sources of income.

**PREVIOUS ACTION**

Fiscal Year 2018 Budget was adopted May 23, 2017.

**BACKGROUND**

**Review of Cash**

The available cash at the end of April, FY18, was \$5,991,807 which is enough cash to cover three months of expenditures. The encumbrances and other liability portion of the cash balance totals \$1.3 million; the portion of cash restricted as to use is approximately \$1.3 million (e.g. Air Quality and the Solid Waste Management programs restricted cash); leaving a balance of approximately \$3.4 million.

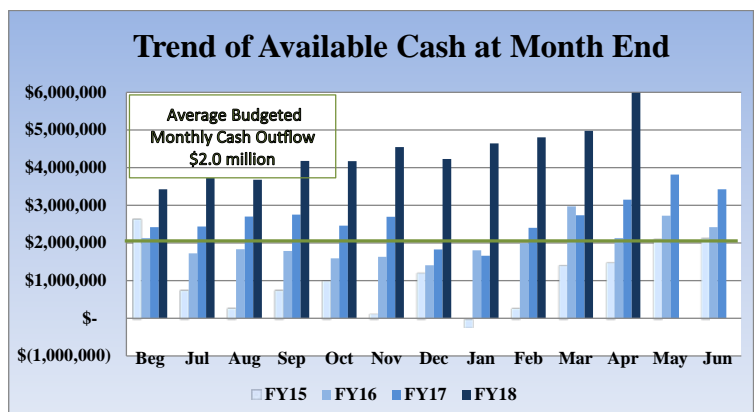

Note: January FY15 negative cash is due to no County General Fund support transferred to the Health Fund.





**Review of Revenues and Expenditures by Division**

**ODHO** has received grant funding of \$3,365 for workforce development initiatives and spent \$777,670 up \$85,694 over FY17 mainly due to: \$27,832 for the staff for the Community Health Needs Assessment and Public Service Interns; \$21,000 for the Public Health Accreditation; and, \$32,500 for the Truckee Meadows Healthy Communities project and matching funds for the Food Bank of Northern Nevada’s Arnold Foundation grant, Collaborating for Communities (C4C).

**AHS** has spent \$938,036 up \$6,251 or 0.7% compared to FY17 mainly due to \$7,659 paid out for accrued vacation time for an employee that left Health District employment.

**AQM** revenues were \$2,845,438 up \$446,499 with the largest year over year increase of \$118,151 in the air pollution permits and \$115,823 increase in the Woodstove Notice of Exemption fees. The Division spent \$2,385,704 up \$25,326 or 1.1% over FY17.

**CCHS** revenues were \$3,172,714 up \$386,014 over FY17 mainly due to additional \$219,220 in grant funding for Family Planning and Chronic Disease, \$61,401 in Medicaid reimbursements, and \$82,449 additional insurance reimbursements and spent \$6,213,013 or \$268,777 more than FY17 due to an increase in salaries and benefits costs and additional biologicals needed for the Immunization Program.

**EHS** revenues were \$3,464,237 up \$797,713 over FY17 with \$647,910 of the increase in licenses and permits, mainly in food service, pool and septic system permits, and \$262,289 in charges for services of which \$199,824 of the increase is in general/land development, and grants and restricted tire fees were down \$112,486. EHS spent \$5,682,748, an increase of \$513,390, over last year due to the \$531,061 increase in chemical costs for the Vector program.

**EPHP** revenues were \$1,355,320 down \$144,757 over last year mainly due to loss of grant funding and spent \$2,063,736 down \$34,322 over FY17 with the majority of that decrease in the operating supplies due to grant funding that ended in FY17.

Washoe County Health District Summary of Revenues and Expenditures Fiscal Year 2013/2014 through April Year to Date Fiscal Year 2017/2018 (FY18)									
	Actual Fiscal Year			Fiscal Year 2016/2017		Fiscal Year 2017/2018			
	2013/2014	2014/2015	2015/2016	Actual Year End (audited)	April Year to Date	Adjusted Budget	April Year to Date	Percent of Budget	FY18 Increase over FY17
<b>Revenues (all sources of funds)</b>									
ODHO	-	-	15,000	51,228	10,723	6,639	3,365	50.7%	-68.6%
AHS	87,930	151	-	-	-	-	-	-	-
AQM	2,491,036	2,427,471	2,520,452	2,979,720	2,398,939	3,197,645	2,845,438	89.0%	18.6%
CCHS	3,388,099	3,520,945	3,506,968	3,872,898	2,786,700	3,905,663	3,172,714	81.2%	13.9%
EHS	1,890,192	2,008,299	2,209,259	3,436,951	2,666,524	3,868,937	3,464,237	89.5%	29.9%
EPHP	1,805,986	1,555,508	2,141,334	2,027,242	1,500,077	1,845,890	1,355,320	73.4%	-9.6%
GF support	8,603,891	10,000,192	10,076,856	10,002,381	8,164,047	10,051,691	8,465,548	84.2%	3.7%
<b>Total Revenues</b>	<b>\$ 18,267,134</b>	<b>\$ 19,512,566</b>	<b>20,469,870</b>	<b>\$22,370,420</b>	<b>\$ 17,527,010</b>	<b>\$ 22,876,465</b>	<b>\$19,306,621</b>	<b>84.4%</b>	<b>10.2%</b>
<b>Expenditures (all uses of funds)</b>									
ODHO	-	481,886	594,672	904,268	691,976	1,163,286	777,670	66.9%	12.4%
AHS	1,336,740	1,096,568	996,021	1,119,366	931,785	1,156,241	938,036	81.1%	0.7%
AQM	2,524,702	2,587,196	2,670,636	2,856,957	2,360,378	3,439,932	2,385,704	69.4%	1.1%
CCHS	6,949,068	6,967,501	6,880,583	7,294,144	5,944,236	7,797,722	6,213,013	79.7%	4.5%
EHS	5,737,872	5,954,567	5,939,960	6,366,220	5,169,359	7,510,913	5,682,748	75.7%	9.9%
EPHP	2,374,417	2,312,142	2,688,659	2,616,411	2,098,058	2,590,833	2,063,736	79.7%	-1.6%
<b>Total Expenditures</b>	<b>\$ 18,922,800</b>	<b>\$ 19,399,859</b>	<b>19,770,532</b>	<b>\$21,157,367</b>	<b>\$ 17,195,792</b>	<b>\$ 23,658,928</b>	<b>\$18,060,907</b>	<b>76.3%</b>	<b>5.0%</b>
<b>Revenues (sources of funds) less Expenditures (uses of funds):</b>									
ODHO	-	(481,886)	(579,672)	(853,040)	(681,253)	(1,156,647)	(774,305)		
AHS	(1,248,810)	(1,096,417)	(996,021)	(1,119,366)	(931,785)	(1,156,241)	(938,036)		
AQM	(33,666)	(159,725)	(150,184)	122,763	38,561	(242,288)	459,734		
CCHS	(3,560,969)	(3,446,556)	(3,373,615)	(3,421,246)	(3,157,536)	(3,892,059)	(3,040,299)		
EHS	(3,847,680)	(3,946,268)	(3,730,701)	(2,929,270)	(2,502,835)	(3,641,976)	(2,218,511)		
EPHP	(568,431)	(756,634)	(547,325)	(589,168)	(597,981)	(744,943)	(708,416)		
GF Operating	8,603,891	10,000,192	10,076,856	10,002,381	8,164,047	10,051,691	8,465,548		
<b>Surplus (deficit)</b>	<b>\$ (655,666)</b>	<b>\$ 112,707</b>	<b>699,338</b>	<b>\$ 1,213,053</b>	<b>\$ 331,219</b>	<b>\$ (782,463)</b>	<b>\$ 1,245,714</b>		
<b>Fund Balance (FB)</b>	<b>\$ 2,155,799</b>	<b>\$ 2,268,506</b>	<b>\$ 2,967,844</b>	<b>\$ 4,180,897</b>		<b>\$ 3,398,434</b>			
<b>FB as a % of Expenditures</b>	<b>11%</b>	<b>12%</b>	<b>15%</b>	<b>20%</b>		<b>14%</b>			

Note: ODHO=Office of the District Health Officer, AHS=Administrative Health Services, AQM=Air Quality Management, CCHS=Community and Clinical Health Services, EHS=Environmental Health Services, EPHP=Epidemiology and Public Health Preparedness, GF=County General Fund

**FISCAL IMPACT**

No fiscal impact associated with the acknowledgement of this staff report.

**RECOMMENDATION**

Staff recommends that the District Board of Health acknowledge receipt of the Health Fund Financial Review for April, Fiscal Year 2018.

**POSSIBLE MOTION**

Move to acknowledge receipt of the Health Fund Financial Review for April, Fiscal Year 2018.

Attachment:  
Health District Fund financial system summary report



Period: 1 thru 10 2018  
 Accounts: GO-P-L P&L Accounts  
 Business Area: \*  
 Fund: 202  
 Fund Center: 000  
 Functional Area: 000  
 Health Fund  
 Default Washoe County  
 Standard Functional Area Hiera

Accounts	2018 Plan	2018 Actuals	Balance	Act%	2017 Plan	2017 Actual	Balance	Act%
460528 NESHAP-AQM	225,847-	172,176-	53,671-	76	153,862-	138,207-	15,655-	90
460529 Assessments-AQM	106,866-	97,924-	8,942-	92	81,614-	72,173-	9,441-	88
460530 Inspector Registr-AQ	6,750-	6,750-	6,750-		4,608-	1,656-	2,952-	36
460531 Dust Plan-Air Quality	334,771-	425,479-	90,708	127	257,784-	368,178-	110,394	143
460532 Plan Rvw Hotel/Motel		6,279-	6,279		2,530-	268-	2,262-	11
460533 Quick Start					251-	251-		
460534 Child Care Inspection	21,169-	17,245-	3,924-	81	14,904-	14,152-	752-	95
460535 Pub Accomod Inspectn	46,666-	33,887-	12,779-	73	33,060-	30,981-	2,080-	94
460570 Education Revenue		138,808-	58,720-	70	97,142-	67,115-	30,028-	69
* Charges for Services	2,553,979-	2,776,502-	222,523	109	1,991,371-	2,053,206-	61,835	103
481150 Interest-Non Pooled		7-	7			40-	40	
484000 Donations,Contributions					4,000-	4,000-		100
484050 Donation Fed Pgm Inc	16,050-	9,503-	6,547-	59	24,201-	12,829-	11,372-	53
484197 Non-Gov. Grants-Ind.	14,428-	12,945-	1,483-	90	11,367-	9,298-	2,069-	82
485100 Reimbursements	46,084-	32,716-	13,368-	71	42,576-	19,281-	23,295-	45
485300 Other Misc Govt Rev		203-	203		35,000-	2,020-	32,981-	6
* Miscellaneous	76,562-	55,374-	21,188-	72	117,144-	47,468-	69,676-	41
** Revenue	12,824,773-	10,841,073-	1,983,700-	85	11,622,973-	9,362,963-	2,260,010-	81
701110 Base Salaries	10,247,216	8,244,291	2,002,925	80	9,864,879	7,969,439	1,895,440	81
701120 Part Time	230,388	218,091	12,297	95	314,723	183,217	131,506	58
701130 Pooled Positions	405,054	355,976	49,078	88	475,463	306,983	168,480	65
701140 Holiday Work	4,319	1,512	2,807	35	4,319	1,667	2,652	39
701150 xcContractual Wages								
701199 Lab Cost Sav-Wages	164,408	79,914	84,494	49	165,730	85,172	80,558	51
701200 Incentive Longevity	68,241	60,528	7,713	89	80,479	70,890	9,589	88
701300 Overtime	300	331	31-	110	287	177	110	62
701403 Shift Differential	38,000	26,916	11,084	71	38,000	25,384	12,616	67
701406 Standby Pay	5,000	1,539	3,461	31	5,000	3,539	1,461	71
701408 Call Back								
701410 Detective Pay								
701412 Salary Adjustment	100,893		100,893		84,557		84,557	
701413 Vac Payoff Sick Term	84,041	12,336	71,705	15	84,423	160,577	76,154-	190
701414 Vacation Denied-Payoff		1,101	1,101-			3,744	3,744-	
701417 Comp Time		3,402	3,402-		0	14,130	14,130-	*0389
701419 Comp Time - Transfer						4	4-	
701500 Merit Awards								
* Salaries and Wages	11,347,860	9,005,937	2,341,923	79	11,117,860	8,824,923	2,292,937	79
705110 Group Insurance	1,634,991	1,295,590	339,400	79	1,755,795	1,349,209	406,586	77
705115 ER HSA Contribs	66,000	93,176	27,176-	141	529	69,268	68,739-	13098
705190 OPEB Contribution	1,305,189	1,087,657	217,531	83	1,181,460	984,550	196,910	83
705199 Lab Cost Sav-Benef								
705210 Retirement	2,979,795	2,398,913	580,882	81	2,907,355	2,313,570	593,785	80

Period: 1 thru 10 2018  
 Accounts: GO-P-L P&L Accounts  
 Business Area: \*  
 Fund: 202 Health Fund  
 Fund Center: 000 Default Washoe County  
 Functional Area: 000 Standard Functional Area Hiera

Accounts	2018 Plan	2018 Actuals	Balance	Act%	2017 Plan	2017 Actual	Balance	Act%
705215 Retirement Calculation								
705230 Medicare April 1986	147,351	123,733	23,618	84	143,403	121,219	22,184	85
705240 Insur Budgeted Incr	48,610		48,610					
705320 Workmens Comp	97,239	80,813	16,427	83	93,193	79,545	13,647	85
705330 Unemply Comp	10,224	9,946	279	97	13,751	10,077	3,675	73
705360 Benefit Adjustment	28,461		28,461		21,529	21,529		
* Employee Benefits	6,317,860	5,089,828	1,228,032	81	6,117,014	4,927,437	1,189,577	81
710100 Professional Services	460,662	156,444	304,218	34	655,630	99,980	555,649	15
710101 Lab Testing Services						4,410	4,410	
710105 Medical Services	9,121	4,132	4,989	45	9,971	4,999	4,972	50
710108 MD Consultants	58,936	36,120	22,816	61	61,210	43,382	17,828	71
710110 Contracted/Temp Svcs	53,610	61,891	8,281-	115	39,600	12,074	27,526	30
710119 Subrecipient Payments								
710155 Lobbying Services						300	300-	
710200 Service Contract	61,929	77,718	15,790-	125	91,731	52,059	39,672	57
710201 Laundry Services		1,508	1,508-					
710205 Repairs and Maintenance	13,645	12,534	1,111	92	14,843	8,815	6,028	59
710210 Software Maintenance	3,000	3,059	59-	102	12,319	2,942	9,378	24
710300 Operating Supplies	151,280	69,767	81,513	46	178,449	118,884	59,565	67
710302 Small Tools & Allow	1,435	51	1,384	4	1,435	1,266	169	88
710308 Animal Supplies	1,600	780	820	49	1,600	1,049	551	66
710312 Special Dept Expense		480	480-					
710319 Chemical Supplies	767,535	766,792	743	100	438,225	235,731	202,494	54
710325 Signs and Markers								
710334 Copy Machine Expense	26,066	15,215	10,852	58	35,875	16,842	19,033	47
710335 Copy Mach-Copies	4,044	5,774	1,730-	143	2,001	4,556	2,555-	228
710350 Office Supplies	36,398	25,760	10,638	71	42,667	32,612	10,055	76
710355 Books and Subscriptions	8,145	8,179	34-	100	15,690	6,681	9,009	43
710360 Postage	19,260	13,968	5,292	73	21,774	12,335	9,439	57
710361 Express and Courier		13	87	13	370	417	47-	113
710391 Fuel & Lube	125		125		125		125	
710400 Fmts to O Agencies	140,650	151,943	11,293-	108	31,500	50,176	18,676-	159
710412 Do Not Use								
710500 Other Expense	27,606	12,389	15,217	45	105,780	10,456	95,324	10
710502 Printing	29,043	9,098	19,945	31	26,573	8,848	17,725	33
710503 Licenses & Permits	8,345	4,913	3,432	59	9,245	4,593	4,652	50
710504 Registration		1,400	1,400-			504	504-	
710505 Rental Equipment		1,812	1,812-		1,800	1,800		100
710506 Dept Inaductible		300	300-			434	434-	
710507 Network and Data Lines	9,050	5,360	3,690	59	9,662	6,562	3,100	68
710508 Telephone Land Lines	35,611	29,797	5,814	84	36,606	28,974	7,632	79
710509 Seminars and Meetings	43,748	34,522	9,226	79	47,577	32,657	14,920	69
710512 Auto Expense	9,870	4,967	4,903	50	13,109	5,961	7,148	45



Period: 1 thru 10 2018  
 Accounts: GO-P-L P&L Accounts  
 Business Area: \*  
 Fund: 202 Health Fund  
 Fund Center: 000 Default Washoe County  
 Functional Area: 000 Standard Functional Area Hiera

Accounts	2018 Plan	2018 Actuals	Balance	Act%	2017 Plan	2017 Actual	Balance	Act%
710514 Regulatory Assessments	20,000	14,885	5,115	74	20,000	10,254	9,746	51
710519 Cellular Phone	14,341	11,382	2,959	79	14,833	11,172	3,661	75
710529 Dues	32,129	31,008	1,121	97	8,362	32,303	23,941	386
710535 Credit Card Fees	51,157	44,404	6,753	87	52,157	22,810	29,347	44
710546 Advertising	167,119	88,723	78,396	53	149,712	170,397	20,685	114
710551 Cash Discounts Lost		6	6			9	9	
710563 Recruitment		771	771					
710571 Safety Expense	57,891	25,468	32,423	44	55,000	50,548	4,452	92
710577 Uniforms & Special C	4,200	6,157	1,957	147	5,657	9,870	4,213	174
710585 Undesignated Budget	794,954		794,954		450,000		450,000	
710594 Insurance Premium	5,815	5,605	210	96	5,815	5,605	210	96
710600 LT Lease-Office Space	76,607	63,839	12,768	83	76,607	60,266	16,341	79
710620 LT Lease-Equipment								
710703 Biologicals	277,612	256,493	21,119	92	302,681	198,600	104,081	66
710714 Referral Services	6,780	5,424	1,356	80	6,780	6,780	6,780	
710721 Outpatient	114,985	62,062	52,923	54	108,555	60,351	48,204	56
710872 Food Purchases	2,744	896	1,848	33	2,994	1,220	1,774	41
711008 Combined Utilities	90,800	75,667	15,133	83	90,800	75,667	15,133	83
711010 Utilities								
711100 ESD Asset Management	40,091	35,280	4,811	88	47,382	38,325	9,057	81
711113 Equip Srv Replace	55,159	41,279	13,880	75	44,876	34,043	10,833	76
711114 Equip Srv O & M	64,486	58,024	6,462	90	66,315	45,756	20,558	69
711115 Equip Srv Motor Pool	5,000		5,000		5,000	3,874	1,126	77
711116 ESD Vehicle Lease								
711117 ESD Fuel Charge	27,852	23,530	4,322	84	34,167	20,447	13,720	60
711119 Prop & Liab Billings	82,007	68,339	13,668	83	82,007	65,590	16,417	80
711210 Travel	168,871	82,633	86,238	49	183,341	62,492	120,849	34
711213 Travel-Non Cnty Fers		1,944	1,944			2,148	2,148	
711300 Cash Over Short		22	22			42	42	
711399 ProCard in Process						41	41	
711400 Overhead - General Fund	1,520,621	1,267,184	253,437	83	1,700,797	1,417,331	283,466	83
711504 Equipment nonCapital	83,270	77,434	5,835	93	75,392	113,464	38,072	150
711508 Computers nonCapital	20,000	1,944	18,056	10				
711509 Comp Sftw nonCap	2,631	4,770	2,139	181				
* Services and Supplies	5,767,936	3,871,858	1,896,078	67	5,494,596	3,350,010	2,144,586	61
781004 Equipment Capital	100,000	70,025	29,975	70	40,472	35,340	5,132	87
781007 Vehicles Capital								
781009 Comp Sftw Capital	25,000	23,260	1,741	93	25,000		25,000	
* Capital Outlay	125,000	93,285	31,716	75	65,472	35,340	30,132	54
** Expenses	23,558,656	18,060,907	5,497,749	77	22,794,942	17,137,710	5,657,232	75
621001 Transfer From General	10,051,691	8,465,548	1,586,143	84	10,002,381	8,164,047	1,838,334	82
* Transfers In	10,051,691	8,465,548	1,586,143	84	10,002,381	8,164,047	1,838,334	82
812230 To Reg Permits-230	100,271	100,271	100,271		58,081	58,081		100

Period: 1 thru 10 2018 P&L Accounts Fund: 202 Health Fund  
 Accounts: GO-P-L Fund Center: 000 Default Washoe County  
 Business Area: \* Functional Area: 000 Standard Functional Area Hiera

Accounts	2018 Plan	2018 Actuals	Balance	Act%	2017 Plan	2017 Actual	Balance	Act%
814430 To Reg Permits Capit								
* Transfers Out	100,271		100,271		58,081	58,081		100
** Other Financing Src/Use	9,951,420-	8,465,548-	1,485,871-	85	9,944,300-	8,105,965-	1,838,334-	82
*** Total	782,463	1,245,714-	2,028,177	159-	1,227,669	331,219-	1,558,888	27-

# Making a Genuine Difference for Our Community



Healthy  Project<sup>SM</sup>

**Renown**<sup>®</sup>  
HEALTH

*Hometown  
Health* 

# Making a Genuine Difference for Our Community

## Alignment to 2015-2018 **CHIP** Initiatives

### Access to Healthcare and Social Services

Subsidized Care  
Community Health Services  
Pregnancy Center  
REMSA Nurse Hotline  
CHA Partnership  
Immunize Nevada Partnership  
Catholic Charities Partnership  
Stanford Health Partnership  
UberHealth Rides  
Community Support Groups

Child Health Institute  
Safe Car Seat Installation  
Addition of Hospital Beds  
Improved ER / Urgent Care Access  
Addition to Primary Care Access  
Improved Network Services Access  
Rural Telemedicine Access  
Interfaith Spiritual Center  
Provider/Care Team Recruitment

### Education

Health Professional Education  
Healthy Nevada  
Senior Caregiver Education  
Child Health Institute  
Save Your Skulls Program

### Behavioral Health

Girls on the Run Partnership  
Behavioral Health Screening  
Behavioral Health and Addiction Institute

### Food Security

Urban Roots Partnership  
Transitional Housing  
Child Health Institute  
Food Security Screening

# Making a Genuine Difference for Our Community

New **Community Benefit Partnerships** in Support of  
The 2018-2021 **Community Health Needs Assessment**

**\$1 Million Budgeted for Fiscal Year 2019  
in Partnerships and Programs**

Addressing **Asthma, Diabetes,  
Adolescent Suicide and Depression**

# Making a Genuine Difference for Our Community

The **Integrated, Not-for-Profit Health System** in Northern Nevada

## Community Benefit

*Providing Treatment and Promoting Health and Healing as a Response to Community Needs*

## Community Development

*Building Community Partnerships to Address Health and Healthcare Needs*

## Community Investment

*Reinvesting Income to Address Health and Healthcare Needs*



# Community Benefit

**\$120 Million** Spent in 2017 in  
Response to Community Needs

## Community Benefit

*Providing Treatment  
and Promoting  
Health and Healing  
as a Response to  
Community Needs*



# Community Benefit

Funded **\$101 Million** in **Free or Discounted Care**  
for the Underinsured in 2017





# Community Benefit

Funded \$8.1 Million in Free and Low-Cost  
Community Health Services in 2017



# Community Benefit

Including **\$2.7 Million** in **Patient Financial Assistance** in 2017



# Community Benefit

Including **\$1.8 Million** for **The Pregnancy Center**  
to Care for **1,552 Underinsured Mothers**



# Community Benefit

Including \$410,000 in Free Health Coaching



# Community Benefit

Including **\$393,000** to Provide **REMSA Nurse Hotline** Services

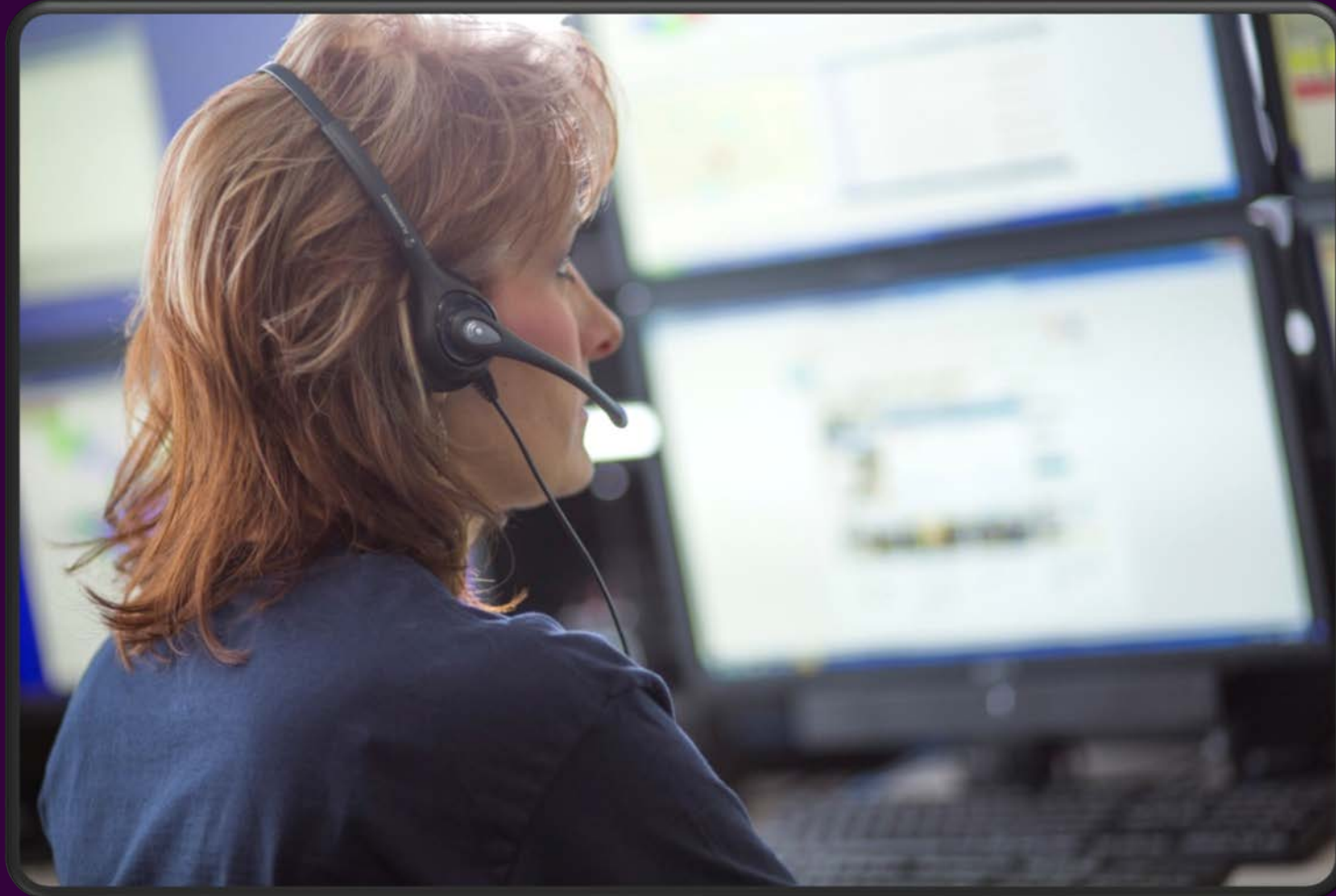

# Community Benefit

Including **\$375,000** to Provide a **Free Source** of **Reliable Health Information** to the Community

**BestMedicine**  
by Renown Health



Mental Illness: Myths,  
Facts, Where to Get  
Support

March 28, 2018



7 Foods to Boost Your  
Mood

March 9, 2018

# Community Benefit

Including **\$216,000** to Provide  
**Health and Wellness** Education Programs



# Community Benefit

Including **\$150,000** to Provide  
**Mental Health and Addiction** Screenings





# Community Benefit

Including **\$110,000** for the Safe Installation of **3,291 Car Seats**



# Community Benefit

Including **\$90,000** to Educate  
**5,500 Students** on Head Injury Prevention



# Community Benefit

Funded **\$5.5 Million** in **Education for Health Professionals**  
in the Community in 2017



# Community Benefit

Funded **\$3.1 Million** in **Research, Contributions,**  
and Other Services in 2017

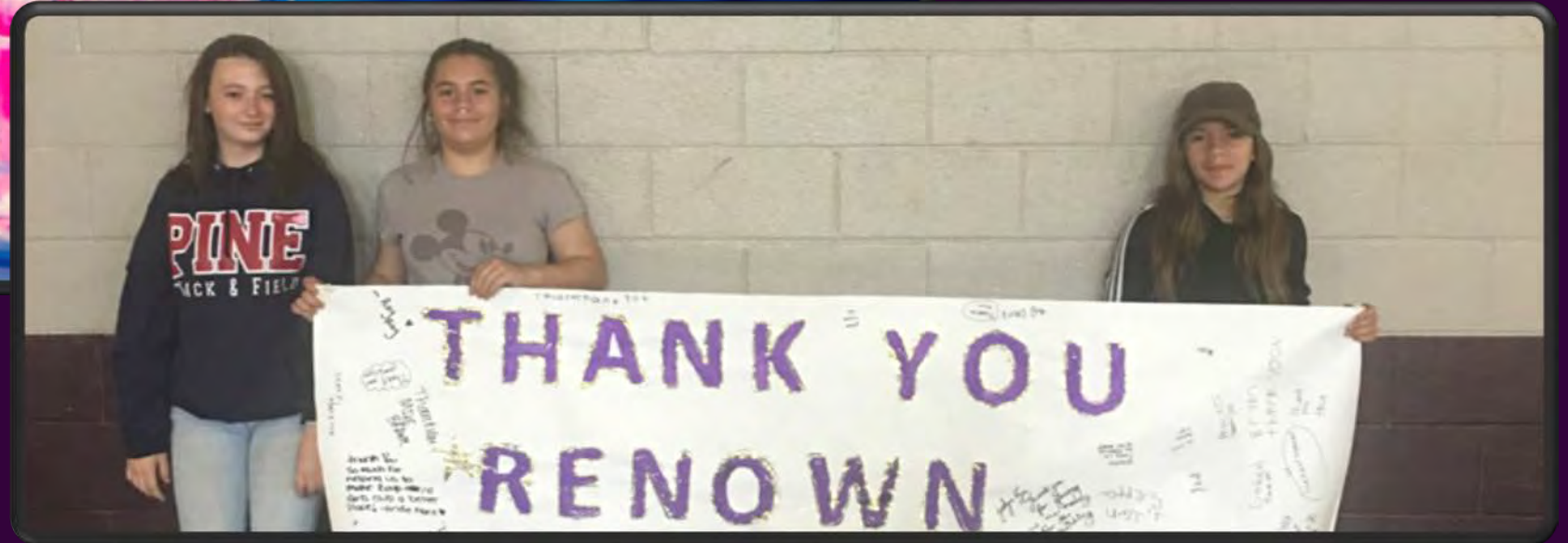

# Community Benefit

Including Providing Genetic Testing  
for **50,000 Northern Nevadans**



# Community Benefit

Including **1,724 Dental Visits** for Vulnerable Populations

COMMUNITY  
HEALTH  
ALLIANCE



# Community Benefit

Including Vaccinations for **3,967 Children**

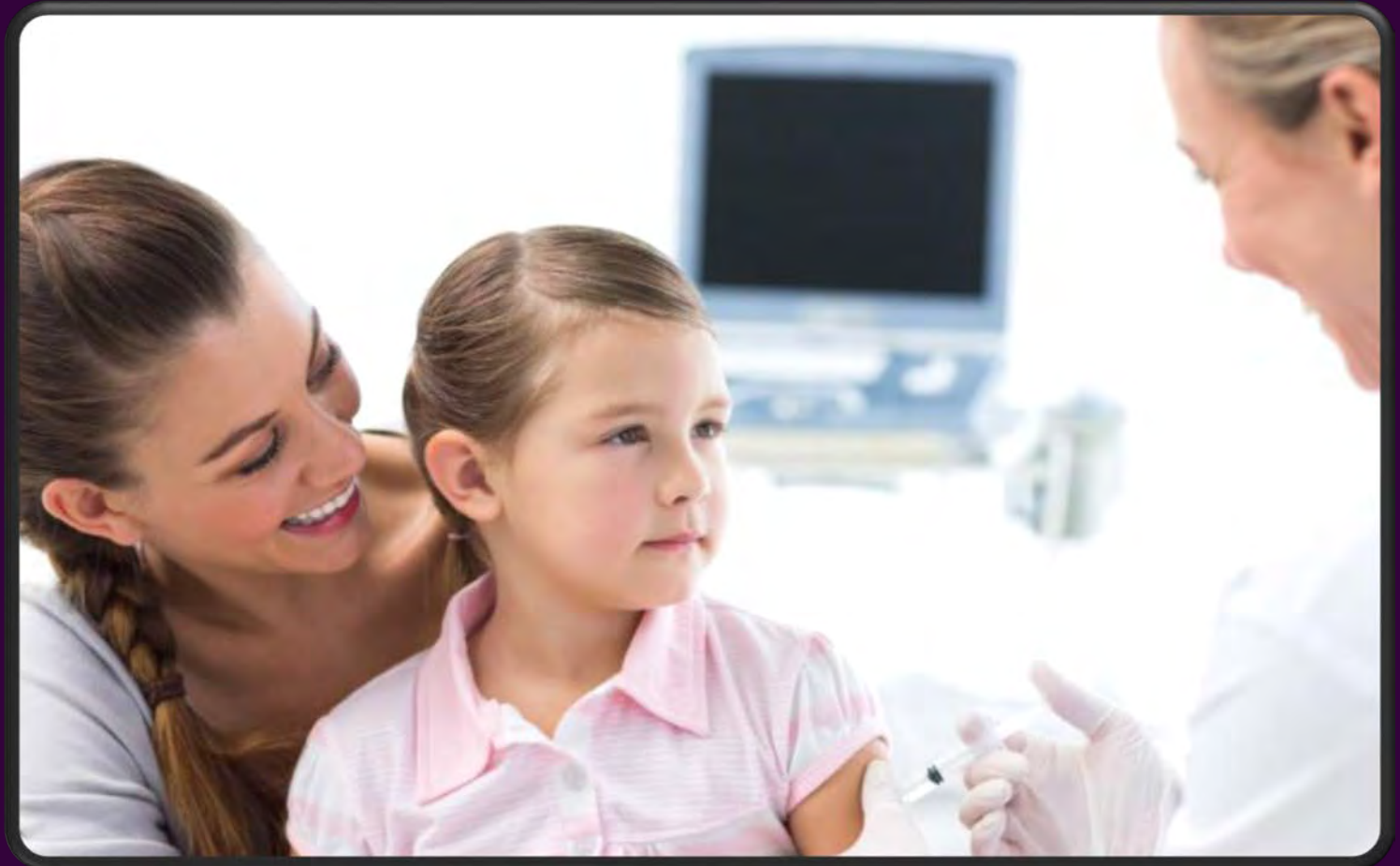

# Community Benefit

Including Mammography Services for **237 Women**

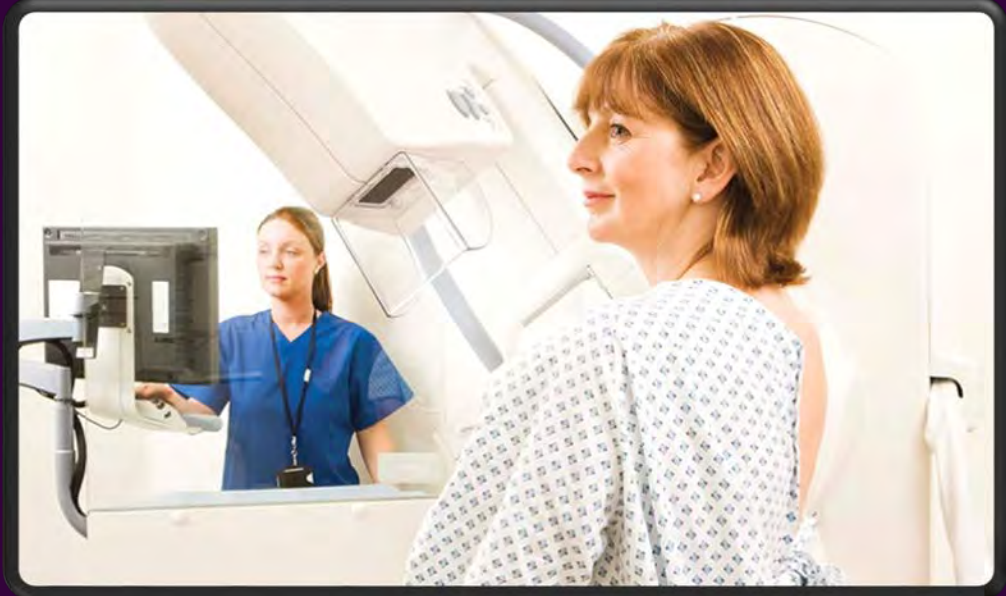

Renown Donates Quarter Million Dollars to New HOPES Community Wellness Center



# Community Benefit

Including **621 Vaccinations** for Seniors

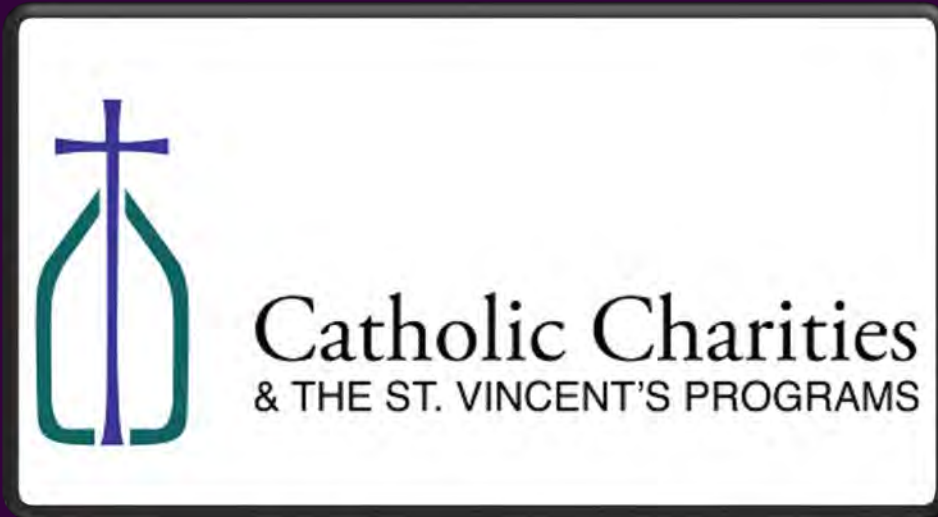

# Community Benefit

Including Health Education for **5,771 Students**  
and Donations of **380 Pounds of Food**



## What's Happening at the Urban Teaching Farm?



SINCE OCTOBER OF 2017, OUR YOUNG FARMERS HAVE GROWN AND HARVESTED  
**405 Pounds of Produce**



WHICH WE SEND TO PARTNERING PANTRIES OF THE FOOD BANK OF NORTHERN NEVADA



WHO HAVE SERVED **9,000** NORTHERN NEVADANS IN THE PRESCRIPTION  
PANTRY PROGRAM SINCE FALL 2017

# Community Benefit

Including Physical and Social Emotional Services for **971 Girls**



# Community Benefit

Including Free Services to Over **2,500 Families**



# Community Development

Partnered with **Community Organizations** to Provide Needed Services in the Community

## Community Development

*Building Community Partnerships to Address Health and Healthcare Needs*



# Community Development

Partnered with **Stanford Health** to Improve Access to Care



# Community Development

Began Partnerships to Provide Housing for Homeless Families  
Currently **9 Children** and **4 Adults**



# Community Development

Funded over **500 UberHealth Rides** To and From Medical Appointments from as far away as Lone Pine





# Community Development

Hosted **Community Support Groups** for MS, Alzheimer's, Stroke, Dementia, Cancer, Epilepsy, and more



# Community Development

Partnered to Educate and Support **Senior Caregivers**

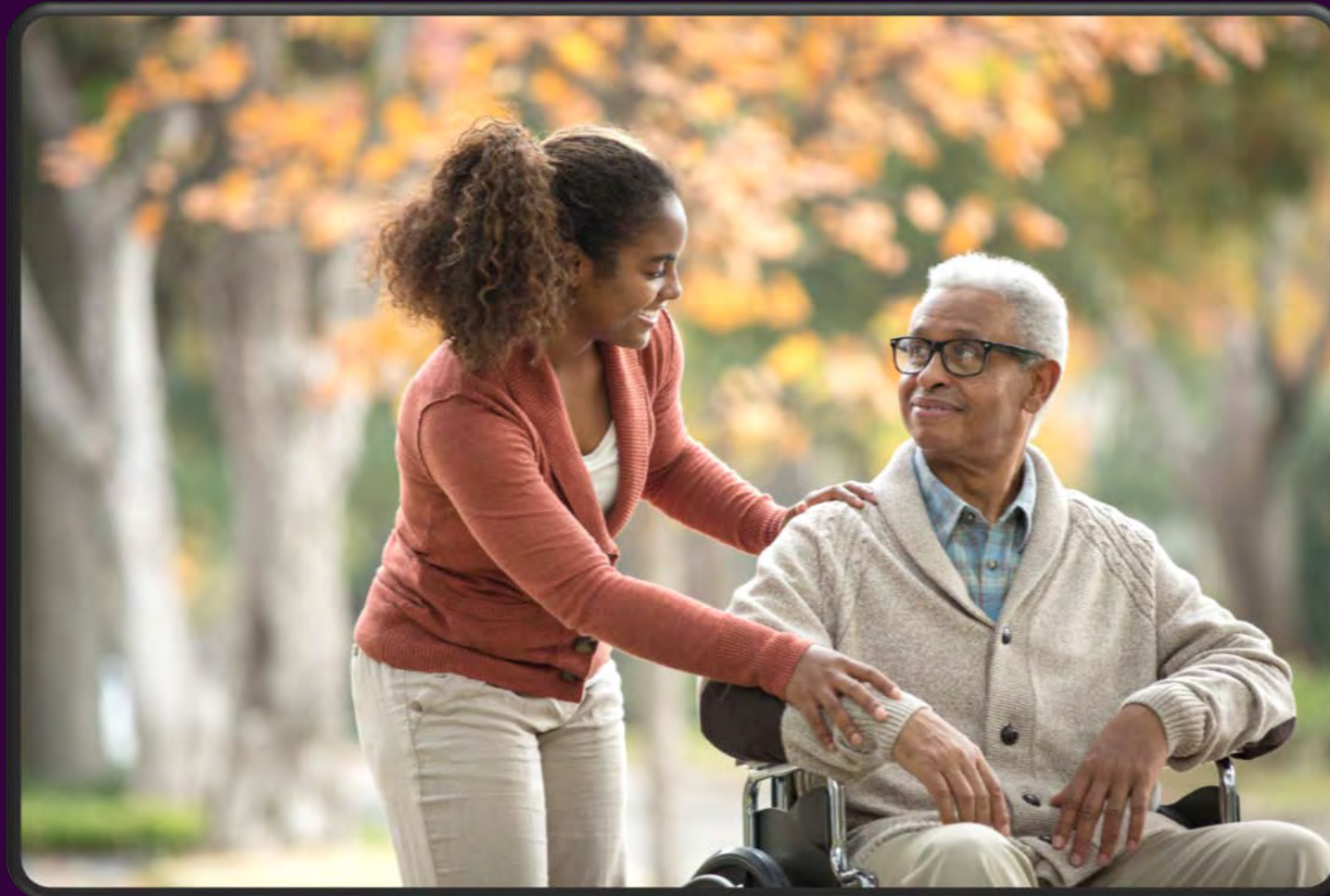

COMMUNITY  
FOUNDATION  
*of Western Nevada*

Washoe Caregivers

**AARP**

Real Possibilities

# Community Development

Built an Institute to Improve **Child Health** in the Community



# Community Development

Screened 12,100 Children for Food Insecurity  
Identified and Referred 211 to Community Food Programs



# Community Development

Built an Institute to Address  
**Behavioral Health and Addiction** in the Community



# Community Investment

Reinvested or Committed **\$210 Million** over 2 Years to  
Improve Access to Health and Healthcare Services



## Community Investment

*Reinvesting Income  
to Address Health  
and Healthcare  
Needs*

# Community Investment

\$20 Million Committed to Increase **Access to Hospital Beds**



# Community Investment

\$2.3 Million Committed to  
Increase Urgent and Emergency Care Access





# Community Investment

Invested \$11.5 Million to Open  
5 New Primary Care Locations in 2016



# Community Investment

Capital Committed for  
5 New Primary Care Locations in 2018 / 2019



# Community Investment

Improving Care with **\$1.6 Million** of Investments  
in **Laboratory Technology**



# Community Investment

Improving Care with **\$2.6 Million** of Investments  
in **Cardiac Technology**



# Community Investment

Improving Care with \$2 Million of Investments  
in Imaging Technology



# Community Investment

Improving Care with **\$7.9 Million** of Investments  
in **Surgical Technology**

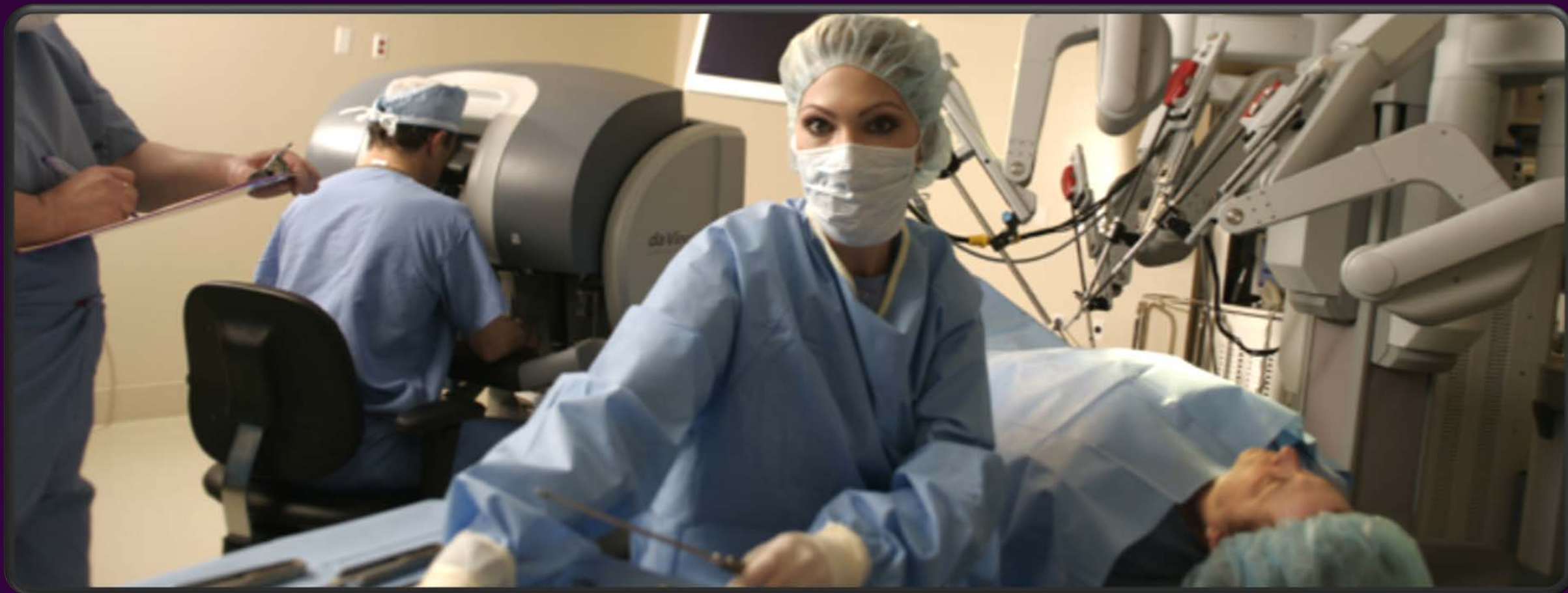

# Community Investment

Made Primary and Specialty Care Available in **Tonopah**



# Community Investment

Expanded Telemedicine to **Rural Communities**  
to Improve Access to Care



Fallon, Stateline, Battle Mountain, Gardnerville, Caliente, Winnemucca, Hawthorne, Elko, Lovelock,  
Fallon, Fernley, Tonopah, Yerington, Susanville, South Lake Tahoe, Portola, Alturas, Quincy, Chester and Lone Pine



# Community Investment

Supported Families with a New  
\$540,000 Interfaith Spiritual Center



# Community Investment

Recruited **175 New Providers** to Improve Access to Care



# Community Investment

Of the 175 - Recruited **22 Pediatric Providers** to  
Let Families Receive Great Care at Home



# Community Investment

Employing Over **7,000 Individuals** in the Community





Healthy  Project™

**Renown**<sup>®</sup>  
HEALTH

*Hometown  
Health* 

DD	CA	
DHO		AD
DA	LA	

**Staff Report**  
**Board Meeting Date: May 24, 2018**

**TO:** District Board of Health

**FROM:** Charlene Albee, Director, Air Quality Management Division  
(775) 784-7211, [calbee@washoecounty.us](mailto:calbee@washoecounty.us)

**SUBJECT:** Review, discussion and possible adoption of the Business Impact Statement regarding Proposed Revisions to the District Board of Health Regulations Governing Air Quality Management, Sections 020.040 (Civil Fines and Penalties) and 020.042 (Criminal Fines and Penalties) with a finding that the revised regulations do not impose a direct and significant economic burden on a business; nor do the revised regulations directly restrict the formation, operation or expansion of a business; and set a public hearing for possible adoption of the proposed revisions to the Regulations for June 28, 2018 at 1:00 pm.

---

**SUMMARY**

The Washoe County District Board of Health (Board) must adopt any changes to the District Board of Health Regulations Governing Air Quality Management (Regulations). Per Nevada Revised Statutes (NRS) 237, Business Impact Statements “must be considered by the governing body at its regular meeting next preceding any regular meeting held to adopt” the proposed revisions.

**District Health Strategic Objective supported by this item: #2 - Healthy Environment:** Create a healthier environment that allows people to safely enjoy everything Washoe County has to offer.

**PREVIOUS ACTION**

Section 020.040 (Civil Fines and Penalties) was last revised on November 16, 2006. That revision increased the fine amounts that shall be levied for minor violations of these regulations to the current levels.

Section 040.042 (Criminal Fines and Penalties) has not been revised since the original adoption on October 20, 1993.

**BACKGROUND**

The review of the fines levied for minor violations resulted from discussions occurring at the District Board of Health Strategic Plan Retreat in 2016. Board members expressed concern the fines were not adequate to provide the necessary incentive to ensure compliance with the regulations. The review of regulations establishing the fines schedule was incorporated as an initiative supporting the goals and objective of the Health District’s Fiscal Year (FY) 2017 Strategic Plan. Due to a staffing shortage in the enforcement section, the initiative was extended into the FY18 Strategic Plan.

During the review of the fine schedule, staff found the fine amounts were not adequate when compared to the costs associated with conducting business. An example is the cost of a water truck is approximately \$800 per day which is significantly more than the initial violation fine amount of \$250. The fine schedule was also compared to other air quality agencies in Nevada and the Western U.S. Clark County Department of Air Quality has a flat fine amount of \$2,000 for a violation of a regulations governing gasoline dispensing and indicated they are also reviewing their fine schedule.

The determination was made to revise the penalties for violations of Section 040.0030 (Dust Control) to not more than \$1000 for a first violation and set a range of not less than \$1000 to not more than \$2000 for a second violation. Additionally, the penalty for a second visible emissions violation was reduced from \$2500 to \$2000 to comply with NRS 445B.640 which sets the limit for a minor violation penalty. Revisions to Section 020.042 (Criminal Fines and Penalties) are also proposed to correct the NRS regulatory references.

On January 10, 2018, the U.S. Environmental Protection Agency (EPA) published a review of their penalties in the Federal Register (Vol. 83, No. 7) in compliance with the Federal Civil Penalties Inflation Adjustment Act of 1990 (Amended 2015). This act requires EPA to review penalties every 4 years to reflect inflation, maintain the deterrent effect of penalties, and promote compliance with the law. As a delegated agency, AQMD is not required to meet the same requirements as EPA but it is strongly encouraged. As previously noted, the penalties in Section 020.040 have not been reviewed and adjusted since 2006.

Presentations were provided to the Nevada Chapter of the Associated General Contractors (March 20, 2018) and the Builders Association of Northern Nevada (April 19, 2018) as an advance notice of the proposed action. No significant comments were received at either meeting. The industry representatives expressed an understanding of why the proposed revisions were needed and did not provide any objections.

Public notice for the revisions to these Regulations was published in the Reno Gazette-Journal on April 23, April 27, and May 1, 2018. The Notice of Proposed Action and the proposed revisions to the regulations were also made available in the "Public Notices" section of the AQMD website ([www.OurCleanAir.com](http://www.OurCleanAir.com)). Public workshops were held on May 2<sup>nd</sup> at noon and at 5:30 pm, to address any questions or concerns, no industry representatives or members of the general public attended either workshop. The published Notice of Proposed Action included instructions that written comments must be submitted to the AQMD by May 4<sup>th</sup>; no comments were received by close of business.

### **FISCAL IMPACT**

There are no fiscal impacts resulting from the Board adopting the Business Impact Statement for the revisions to the regulations as the revisions will not require any modifications to the existing administrative duties associated with the implementation of the program.

### **RECOMMENDATION**

Staff recommends the District Board of Health approve and adopt the Business Impact Statement for the proposed revisions to the District Board of Health Regulations Governing Air Quality Management, Section 020.040 (Civil Fines and Penalties) and 020.042 (Criminal Fines and Penalties), and set a public hearing for possible adoption of said revisions for June 28, 2018 at 1:00 pm.

### **POSSIBLE MOTION**

Should the Board agree with staff's recommendation, a possible motion would be:

"Move to approve and adopt the Business Impact Statement for the proposed revisions to the District Board of Health Regulations Governing Air Quality Management, Section 020.040 (Civil Fines and Penalties) and 020.042 (Criminal Fines and Penalties), with a finding that the proposed regulations will not impose a direct and significant economic burden on a business; nor does the proposed regulations directly restrict the formation, operation or expansion of a business. Further move to set a public hearing for possible adoption of the proposed regulations for June 28, 2018 at 1:00 pm.

The following business impact statement was prepared pursuant to NRS 237.090 to address the proposed impact of the revision to the DBOH Regulations Governing Air Quality Management, Section 020.040 Civil Fines and Penalties.

1. The following constitutes a description of the manner in which comment was solicited from affected businesses, a summary of their response and an explanation of the manner in which other interested persons may obtain a copy of the summary. (*List all trade association or owners and officers of businesses likely to be affected by the proposed rule that have been consulted*).

Presentations were provided to the Nevada Chapter of the Associated General Contractors (March 20, 2018) and the Builders Association of Northern Nevada (April 19, 2018) as an advance notice of the proposed action. No significant comments were received at either meeting. The industry representatives expressed an understanding of why the proposed revisions were needed and did not provide any objections. Notification of the public hearing to address the proposed regulation changes was published on April 23, April 27 and May 1, 2018, in the Reno Gazette Journal. The Notice of Proposed Action and copy of the proposed rule revisions were also posted on the Air Quality Management Division website at OurCleanAir.com. Two public workshops were held on May 2, 2018, at noon and at 5:30 pm. The notification also included a request to submit comments to the Air Quality Management Division by May 4, 2018. No one attended either workshop nor was any comments received by the deadline.

2. The estimated economic effect of the proposed rule on businesses, including, without limitation, both adverse and beneficial effects, and both direct and indirect effects:

Adverse effects: The regulation has no adverse effects on businesses operating in compliance with the regulations.

Beneficial effects: The regulation has no beneficial effect on businesses operating in compliance with the regulations.

Direct effects: Incentive to operate in compliance with the District Board of Health Regulations Governing Air Quality Management.

Indirect effects: Incentive to operate in compliance helps to avoid expenses resulting from corrective actions.

3. The following constitutes a description of the methods the local government considered to reduce the impact of the proposed rule on businesses and a statement regarding whether any, and if so, which of these methods were used: (*Include whether the following was considered: simplifying the proposed rule; establishing different standards of compliance for a business; and if applicable, modifying a fee or fine set forth in the rule so that business could pay a lower fee or fine*).

There should be no financial impact to business owners operating in compliance with the regulations.

4. The governing body estimates the annual cost to the local government for enforcement of the proposed rule is:

There is no increase in anticipated annual cost as the work is already being conducted.

5. The proposed rule provides for a new fee or increases an existing fee and the total annual amount expected to be collected is:

N/A. All fines collected are directed to the Washoe County School District.

6. The money generated by the new fee or increase in existing fee will be used by the local government to:

Implement environmental projects by the Washoe County School District.

7. The proposed rule includes provisions that duplicate or are more stringent than federal, state or local standards regulating the same activity. The following explains when such duplicative or more stringent provisions are necessary:

The proposed change is not duplicative, nor more stringent than existing federal, state or local standards.



8. The following constitutes an explanation of the reasons for the conclusions regarding the impact of the proposed rule on businesses:

*The proposed rule will have no impact on businesses operating in compliance with the regulations.*

To the best of my knowledge or belief, the information contained in this statement is prepared properly and is accurate.



---

Kevin Dick, District Health Officer

May 10, 2018

Date

**020.040 CIVIL FINES AND PENALTIES** (Amended 4/88, 10/20/93, 11/16/94; Revised 8/26/04, 11/16/06, [mm/dd/yy](#))

- A. Except as provided in **Subsections B and C**, a violation of any section of these regulations constitutes a major violation. Any violation of a permit condition shall be a major violation as specified in **Section 030.2175** of these regulations.
- B. Any person who commits a major violation of any section of these regulations, other than **Sections 020.050 and 020.055**, is guilty of a civil offense and may be required to pay an administrative fine of not more than \$10,000.00. Each day of violation constitutes a separate offense. The District Board of Health may establish a compliance schedule as a part of any civil finding either in lieu of, or in addition to, monetary penalties. Any fines assessed may be held in abeyance pending fulfillment of any compliance schedule.
- C. Any violation of **Sections 040.030, 040.035, 040.040(A), 040.050, 040.051, 040.055, 040.080, or 050.001** of these regulations constitutes a minor violation unless the violation occurs on more than two (2) occasions during a period of twelve (12) consecutive months. In that event, the third (3rd) and any subsequent violations constitute major violations.
- D. The following fines shall be levied for minor violations of these regulations:

	<b>First Violation</b>	<b>Second Violation</b>
<b>Section 040.030</b> (Dust Control)		
A. Violation of Dust Permit Condition(s)	<del>not less than 100</del> Not more than <del>250</del> <u>1000</u>	not less than <del>250</del> <u>1000</u> not more than <del>750</del> <u>2000</u>
B. Visual Emission Violation	<del>not less than 500</del> not more than 1000	not less than 1000 not more than <del>2500</del> <u>2000</u>
<b>Section 040.035</b> (Open Fires)	not more than 500	not less than 500 not more than 1000
<b>Subsection A of Section 040.040</b> (Fire Training)	not more than 500	not less than 500 not more than 1000
<b>Section 040.050</b> (Incinerator Emission)	not more than 1000	not less than 1000 not more than 2000
<b>Section 040.051</b> (Certified Woodstoves)	not more than 500	not less than 500 not more than 1000
<b>Section 040.055</b> (Odors)	not more than 1000	not less than 1000 not more than 2000
<b>Section 040.080</b> (Gasoline Transfer)	not more than 1000	not less than 1000 not more than 2000

Section 040.200  
(Diesel Idling)

not more than 500

not less than 500  
not more than 1000

Section 050.001  
(Emergency Episode)

not more than 1000

not less than 1000  
not more than 2000

E. Administrative fines shall be levied by appropriate action of the District Board of Health and recorded in its official minutes. The evidence or information on which the District Board of Health bases its action may include any one or more of the following:

1. The recommendation of the Control Officer based on any Notice of Violation served on any person in accordance with these regulations, if that person has not appeared or requested a hearing before the Hearing Board.
2. The recommendation of the Hearing Board, based on its findings in connection with any appeal or other matter referred to the Board in accordance with these regulations.
3. Evidence presented before the District Board of Health by any person, public official, or representative of the District Board of Health or District Health Department, provided the person charged with violating any of these regulations has received reasonable notice (at least twenty (20) days in advance) of the hearing at which such evidence is to be presented and is provided an opportunity to present evidence in his defense at the hearing.

F. Unless the Board of Health bases its decision on the recommendations and/or findings of the Control Officer or the Hearing Board as set forth in **Paragraphs 1 and 2 of Subsection E**, the Board shall base its decision as to whether a violation of these regulations has occurred on the evidence presented before the Board pursuant to **Paragraph 3** of that subsection. Irrelevant, immaterial or unduly repetitious evidence shall be excluded. Documentary evidence may be received in the form of authenticated copies or excerpts if the original is not readily available and, on request, parties shall be given an opportunity to compare the copy with the original. Each party may call and examine witnesses, introduce exhibits, cross-examine opposing witnesses on any matter relevant to the issues even though such matter was not covered in the direct examination, impeach any witness regardless of which party first was called to testify and rebut the evidence against him. The Board of Health may take notice of judicially cognizable facts and/or recognized technical or scientific facts within the Board's specialized knowledge. All decisions of the Board of Health respecting administrative fines shall be in writing or notice of the Board's decision shall be forwarded to the aggrieved party at his last known mailing address.

G. ~~If any person served with a Notice of Violation in accordance with these regulations is charged with committing a minor violation, he may voluntarily waive his right to appear before the Hearing Board and remit to the District Health Department within ten (10) days after service of the Notice of Violation an amount in accordance with the minimum prescribed for such violation set forth in Subsection D by cashier's check, certified check or money order made payable to the Washoe County District Health Department.~~ All ~~other~~ fines shall be levied by formal action of the District Board of Health. The Control Officer may suspend, deny or revoke any or all permits of a person who has failed to pay any fine that has been levied by the District Board of Health.

H. In those cases where it is determined by the District Board of Health that a violation of the Regulations has occurred, the Board at its discretion may choose to waive the fine for a first violation, levy any fine

providing it does not exceed the appropriate range limitation, require use of other mitigation methods or schedules of compliance and in emergency situations, require a Stop Work Order to be issued and/or any other combination of remedies to bring about compliance with the Regulations.

- I. All administrative fines collected by the District Board of Health pursuant to this section shall be deposited in the school district fund of Washoe County.
- J. All monetary fines assessed pursuant to violations of **Sections 030.105 or 030.107** for improper asbestos containing material removal, shall be for an amount greater than the estimated savings obtained by the illegal removal.

#### 020.042 CRIMINAL FINES AND PENALTIES (Adopted 10/20/93)

A. Any person who knowingly:

- 1. makes any false statement, representation or certification;
- 2. falsifies, tampers with, renders inaccurate or fails to install any required monitoring device or method;
- 3. alters, conceals, fails to file or maintain any required document;
- 4. fails to pay any fee;
- 5. violates any applicable requirement; or
- 6. violates the terms or conditions of any permit.

as required under NRS ~~445.401~~445B.100 to ~~445.526~~445B.450, inclusive, or NRS ~~445.546~~445B.470 to ~~445.601~~445B.640, inclusive or any regulations adopted pursuant to those provisions shall pay a fine of not more than \$10,000.

B. Each day of violation of the provisions of subsection A constitutes a separate offense.



**REMSA**

**FRANCHISE COMPLIANCE  
REPORT**

**APRIL 2018**



**REMSA Accounts Receivable Summary  
Fiscal 2018**

Month	#Patients	Total Billed	Average Bill	YTD Average	Average Collected
July	3986	\$4,530,081.40	\$1,136.50	\$1,136.50	\$409.14
August	4101	\$4,669,433.60	\$1,138.61	\$1,137.57	\$409.52
September	4059	\$4,631,774.80	\$1,141.11	\$1,138.75	\$409.95
October	3812	\$4,346,731.00	\$1,140.28	\$1,139.12	\$410.08
November	4026	\$4,580,696.00	\$1,137.78	\$1,138.85	\$409.98
December	4428	\$5,139,837.20	\$1,160.76	\$1,142.82	\$411.42
January	4239	\$4,948,942.20	\$1,167.48	\$1,146.47	\$412.73
February	3844	\$4,582,675.00	\$1,192.16	\$1,151.87	\$414.67
March	4157	\$4,953,807.00	\$1,191.68	\$1,156.39	\$404.74
<b>Totals</b>	<b>36652</b>	<b>\$42,383,978</b>	<b>\$1,156.39</b>		

Allowed ground average bill: 1/1/18 3% increase  
\$ 1,196.07  
 Monthly average collection rate: \$1,161.23  
 36.0%  
 Monthly average collection rate rev 3.1.18: 35%

**Fiscal Year 2017-2018**

<b>COMPLIANCE</b>			
Month	Priority 1 System - Wide Avg. Response Time	Priority 1 Zone A	Priority 1 Zones B,C,D
Jul-17	5 Minutes 43 Seconds	93%	91%
Aug-17	5 Minutes 38 Seconds	93%	93%
Sep-17	5 Minutes 43 Seconds	92%	97%
Oct-17	5 Minutes 45 Seconds	92%	92%
Nov-17	5 Minutes 38 Seconds	92%	96%
Dec-17	5 Minutes 52 Seconds	91%	93%
Jan-18	5 Minutes 39 Seconds	93%	95%
Feb-18	5 Minutes 48 Seconds	92%	96%
Mar-18	5 Minutes 53 Seconds	91%	93%
Apr-18	5 Minutes 41 Seconds	93%	96%



**Year to Date: July 2017 thru April 2018**

Priority 1 System - Wide Avg. Response Time	Priority 1 Zone A	Priority 1 Zones B, C, D
5 Minutes 44 Seconds	92%	94%

**Year to Date: July 2017 through April 2018**

AVERAGE RESPONSE TIMES BY ENTITY				
Month/Year	Priority	Reno	Sparks	Washoe County
Jul-17	P-1	4:56	5:49	7:48
	P-2	5:06	6:08	8:23
Aug-17	P-1	4:55	5:48	8:09
	P-2	5:03	6:03	7:59
Sep-17	P-1	5:01	5:45	8:06
	P-2	5:21	6:25	6:06
Oct-17	P-1	5:09	5:53	8:05
	P-2	5:22	6:14	8:01
Nov-17	P-1	5:09	5:39	7:34
	P-2	5:13	6:49	8:05
Dec-17	P-1	5:02	6:01	8:30
	P-2	5:23	6:02	8:38
Jan-18	P-1	5:03	5:47	7:56
	P-2	5:06	5:59	7:28
Feb-18	P-1	5:07	5:52	8:03
	P-2	5:24	6:27	8:14
Mar-18	P-1	5:13	6:15	8:06
	P-2	5:32	6:11	8:20
Apr-18	P-1	5:08	5:49	7:52
	P-2	5:07	6:00	8:00

**Year to Date: July 2017 through April 2018**

Priority	Reno	Sparks	Washoe County
P-1	5:06	5:52	8:01
P2	5:15	6:13	8:13



**REMSA OCU INCIDENT DETAIL REPORT  
PERIOD: 01/01/2018 THRU 04/30/2018**

CORRECTIONS REQUESTED					
Zone	Clock Start	Clock Stop	Unit	Response Time Original	Response Time Correct
Zone A	4/6/2018 13:17	4/6/2018 13:22	1C40	0:00:00	0:05:08
Zone A	4/7/2018 16:23	4/7/2018 16:27	1W03	0:03:36	0:03:36
Zone A	4/7/2018 18:07	4/7/2018 18:11	4/7/2018	0:23:08	0:04:02
Zone A	4/10/2018 8:20	4/10/2018 8:21	1C30	-00:01:03	0:00:44
Zone A	4/11/2018 13:18	4/11/2018 13:21	1C19	0:02:28	0:02:28
Zone A	4/11/2018 16:28	4/11/2018 16:32	1C38	-00:00:28	0:04:14
Zone A	4/13/2018 15:40	4/13/2018 15:43	1W03	0:00:00	0:02:43
Zone A	4/14/2018 18:26	4/14/2018 18:28	1C14	-00:03:31	0:01:37
Zone A	4/17/2018 15:19	4/17/2018 15:20	1C41	-00:01:00	0:00:58
Zone A	4/17/2018 22:40	4/17/2018 22:45	1C07	0:04:58	0:04:58
Zone A	4/20/2018 17:10	4/20/2018 17:12	1C06	-00:00:32	0:01:37
Zone A	4/20/2018 23:26	4/20/2018 23:26	1C44	-00:00:09	0:00:16
Zone A	4/21/2018 22:09	4/21/2018 22:18	1C35	0:08:35	0:08:35
Zone A	4/24/2018 19:14	4/24/2018 19:15	1C31	-00:00:11	0:00:23
Zone A	4/25/2018 17:28	4/25/2018 17:29	1C08	-00:00:02	0:01:59
Zone A	4/26/2018 19:45	4/26/2018 19:51	1C07	0:07:43	0:06:19
Zone A	4/26/2018 20:45	4/26/2018 20:49	1C07	0:05:04	0:04:29
Zone A	4/26/2018 22:27	4/26/2018 22:33	1C07	0:07:25	0:06:25
Zone A	4/26/2018 23:48	4/26/2018 23:56	1C07	0:07:48	0:07:40
Zone A	4/27/2018 19:47	4/27/2018 19:51	1C24	-00:02:12	0:03:52
Zone A	4/28/2018 12:26	4/28/2018 12:31	1C31	0:05:12	0:05:12
Zone A	4/29/2018 15:35	4/29/2018 15:37	1C29	-00:00:07	0:02:20

UPGRADE REQUESTED						
Response Area	Zone	Clock Start	Clock Stop	Unit	Threshold	Response Time.
<b>None</b>						

EXEMPTIONS REQUESTED					
Incident Date	Approval	Exemption Reason	Zone	Response Time	Overage
04-2018	None	None	None	None	None





## GROUND AMBULANCE OPERATIONS REPORT APRIL 2018

### 1. Overall Statics

- a) Total number of system responses: 6040
- b) Total number of responses in which no transports resulted: 2265
- c) Total number of System Transports (including transports to out of county): 3775

### 2. Call Classification

- a) Cardiopulmonary Arrests: 1.1 %
- b) Medical: 50.6%
- c) Obstetrics (OB): 0.5%
- d) Psychiatric/Behavioral: 8.9%
- e) Transfers: 9.5%
- f) Trauma – MVA: 6.1%
- g) Trauma – Non MVA: 20.3%
- h) Unknown: %

### 3. Medical Director's Report

- a) The Clinical Director or designee reviewed:
  - 100% of cardiopulmonary arrests
  - 100% of pediatric patients (transport and non-transport)
  - 100% of advanced airways (excluding cardio pulmonary arrests)
  - 100% of STEMI alerts or STEMI rhythms
  - 100% of deliveries and neonatal resuscitation
  - 100% Advanced Airway Success rates for nasal/oral intubation and King Airway placement for adult and pediatric patients.

**Total number of ALS Calls: 2008**

**Total number of above calls receiving QA Reviews: 422**

**Percentage of charts reviewed from the above transports: 21%**



## REMSA EDUCATION APRIL 2018 MONTHLY COURSE AND STUDENT REPORT

Discipline	Total Classes	Total Students	REMSA Classes	REMSA Students	Site Classes	Site Students
ACLS	4	32	3	29	1	3
ACLS EP	0	0	0	0	0	0
ACLS EP I	0	0	0	0	0	0
ACLS I	8	1	8	1	0	0
ACLS P	1	1	1	1	0	0
ACLS R	22	80	8	41	14	39
ACLS S	10	37	1	1	9	36
AEMT	0	0	0	0		
BLS	70	429	12	80	58	349
BLS I	2	9	1	1	1	8
BLS R	34	207	25	158	9	49
BLS S	15	26	0	0	15	26
B-CON	2	9	2	9	0	0
CE	2	42	2	42	0	0
EMAPCT	0	0	0	0	0	0
EMPACT I	0	0	0	0	0	0
EMR	0	0	0	0		
EMR R	0	0	0	0		
EMS I	0	0	0	0		
EMT	1	19	1	19		
EMT R	0	0	0	0		
FF CPR	11	38	1	3	10	35
FF CPR FA	0	0	0	0	0	0
FF FA	0	0	0	0	0	0
HS BBP	0	0	2	37	0	0
HS CPR	26	184	7	64	19	120
HS CPR FA	67	527	8	88	59	439
HS CPR FA S	0	0	0	0	0	0
HS CPR PFA	3	18	0	0	3	18
HS PFA S	0	0	0	0	0	0
HS CPR S	2	2	0	0	2	2
HS FA	11	29	2	2	9	27
HS FA S	0	0	0	0	0	0
HS K-12 CPR AED	26	217	0	0	26	217
HS K-12 CPR, AED, FA	8	47	0	0	8	47
HS PFA	0	0	0	0	0	0
HS Primeros Auxilios, RCP y DEA	1	5	1	5	0	0
HS Spanish RCP y DEA	0	0	0	0	0	0
ITLS	0	0	0	0	0	0
ITLS A	0	0	0	0	0	0
ITLS I	0	0	0	0	0	0
ITLS P	0	0	0	0	0	0
ITLS R	0	0	0	0	0	0
ITLS S	0	0	0	0	0	0



**REMSA EDUCATION  
APRIL 2018 MONTHLY COURSE AND STUDENT REPORT  
CONTINUED**

Discipline	Total Classes	Total Students	REMSA Classes	REMSA Students	Site Classes	Site Students
Kid Care	1	9	1	9	0	0
PALS	4	13	2	11	2	2
PALS I	0	0	0	0	0	0
PALS R	12	64	6	42	6	22
PALS S	4	10	1	1	3	9
PHTLS	1	6	1	6	0	0
PHTLS R	0	0	0	0	0	0
PM	1	15	1	15		
PM R	0	0	0	0		
<b>Classes w/CPR</b>		<b>CPR Students</b>		<b>REMSA CPR Classes</b>		<b>REMSA CPR Students</b>
266		1718		56		408



### COMMUNITY OUTREACH APRIL 2018

Point of Impact		
04/01/18	Child car seat checkpoint hosted by Champion Chevrolet; 5 cars and 8 seats inspected.	10 Volunteers; 3 Staff
04/28/18	Child car seat checkpoint hosted by Immunize Nevada and Safe Kids Washoe County at Meadowood Mall; 7 cars and 9 seats inspected.	9 Volunteers; 2 Staff
April 2018	Twelve office installation appointments; 13 cars and 20 seats inspected.	
Cribs for Kids/Community		
04/06/18	C4K taught the Train-the Trainer Class at Nevada Health Centers WIC in Las Vegas Nevada.	60 Participants
04/10/18	C4K participated in Safe Kids Coalition Meeting.	
04/11/18	C4K had a site visit with Division of Public and Behavioral Health at REMSA. Included REMSA's Coordinator, Education Manager, and CFO to be present.	
04/12/18	C4K attended Northern Nevada Maternal Child Health Coalition meeting.	
04/12/18	Called in Northern Nevada Vision Zero meeting for pedestrian safety.	
04/14/18	Attended checkpoint hosted by Champion Chevrolet as a technician.	
04/19/18	Attended 20 <sup>th</sup> Annual Silver Syringe Awards through Immunize Nevada with Education Manager.	
04/20/18	C4K held a booth at the Health & Community Social put on by B.R.A.I.N Nevada.	25 Participants
04/23/18	C4K held booth in Gardnerville in their County Community Center for the Community Baby Showered through Immunize Nevada.	50 Participants, donated 2 safe sleep kits
04/25/18	C4K participated in Webinar by National Institute for Children's Health Quality (NICHQ) on Improving infant safe sleep strategies for helping families adopt safe sleep habit.	
04/28/18	C4K held booth at Meadow wood Mall at their Community Baby Showered through Immunize Nevada.	200 Participants, donated 2 safe sleep kits



REMSA

Reno, NV  
Client 7299



1515 Center Street  
Lansing, Mi 48096  
1 (877) 583-3100  
service@EMSSurveyTeam.com  
www.EMSSurveyTeam.com

## EMS System Report

April 1, 2018 to April 30, 2018

Your Score

**94.18**

Number of Your Patients in this Report

**150**

Number of Patients in this Report

**7,143**

Number of Transport Services in All EMS DB

**146**





## Executive Summary

This report contains data from **150 REMSA** patients who returned a questionnaire between **04/01/2018** and **04/30/2018**.

The overall mean score for the standard questions was **94.18**; this is a difference of **1.55** points from the overall EMS database score of **92.63**.

The current score of **94.18** is a change of **-0.26** points from last period's score of **94.44**. This was the **36th** highest overall score for all companies in the database.

You are ranked **11th** for comparably sized companies in the system.

**86.66%** of responses to standard questions had a rating of Very Good, the highest rating. **97.05%** of all responses were positive.

### 5 Highest Scores

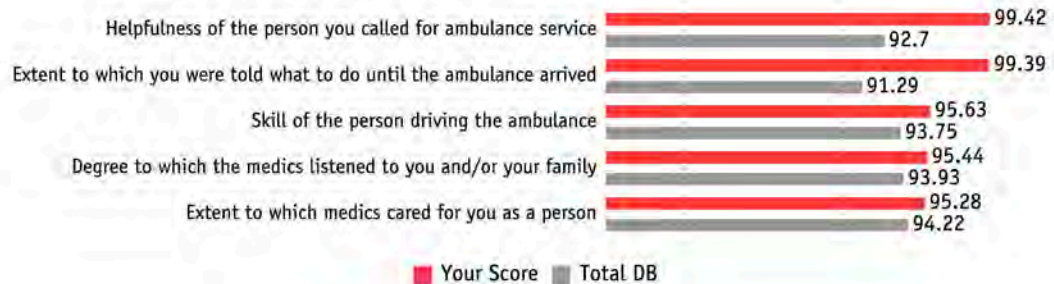

### 5 Lowest Scores



REMSA  
**April 1, 2018 to April 30, 2018**



**Demographics** — This section provides demographic information about the patients who responded to the survey for the current and the previous periods. The information comes from the data you submitted. Compare this demographic data to your eligible population. Generally, the demographic profile will approximate your service population.

	Last Period				This Period			
	Total	Male	Female	Other	Total	Male	Female	Other
Under 18	4	3	1	0	5	3	2	0
18 to 30	14	8	6	0	19	12	7	0
31 to 44	17	9	8	0	12	5	7	0
45 to 54	12	2	10	0	22	13	9	0
55 to 64	25	12	13	0	33	14	19	0
65 and older	78	39	39	0	59	22	37	0
<b>Total</b>	<b>150</b>	<b>73</b>	<b>77</b>	<b>0</b>	<b>150</b>	<b>69</b>	<b>81</b>	<b>0</b>

**Age Ranges**

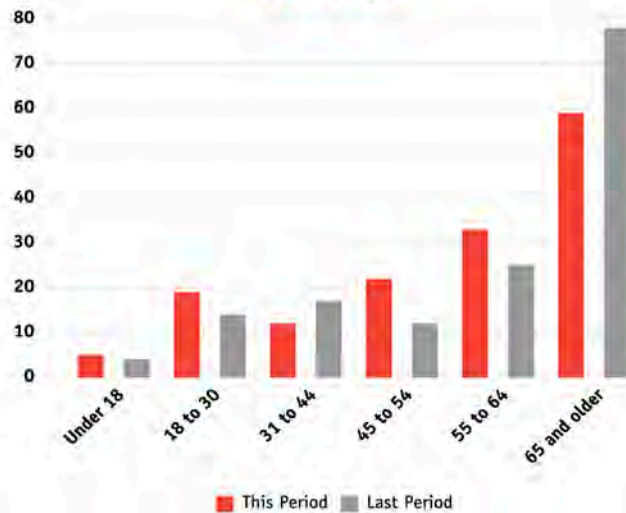

**Gender**

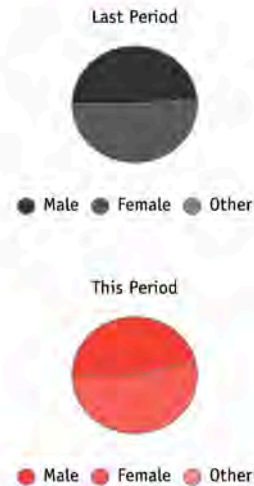

REMSA  
**April 1, 2018 to April 30, 2018**



**Monthly Breakdown**

Below are the monthly responses that have been received for your service. It details the individual score for each question as well as the overall company score for that month.

	Apr 2017	May 2017	Jun 2017	Jul 2017	Aug 2017	Sep 2017	Oct 2017	Nov 2017	Dec 2017	Jan 2018	Feb 2018	Mar 2018	Apr 2018
Helpfulness of the person you called for ambulance service	95.45	96.59	91.69	95.21	95.21	93.13	90.58	93.13	97.56	93.55	90.95	92.53	99.42
Extent to which you were told what to do until the ambulance	94.26	94.77	92.10	91.48	96.02	89.89	92.33	94.59	95.65	93.77	90.52	92.97	99.39
Extent to which the ambulance arrived in a timely manner	95.39	92.40	93.40	92.01	95.01	95.44	92.37	92.87	95.84	95.36	92.30	95.11	93.55
Cleanliness of the ambulance	98.13	95.17	97.11	96.04	96.57	99.09	96.82	96.12	98.26	96.49	93.00	96.01	94.53
Skill of the person driving the ambulance	96.23	96.01	95.42	95.49	96.40	96.44	96.82	95.26	96.96	96.12	93.93	95.43	95.63
Care shown by the medics who arrived with the ambulance	98.08	94.47	94.74	95.12	93.90	96.19	93.68	95.49	95.45	95.78	92.94	95.59	94.37
Degree to which the medics took your problem seriously	98.19	93.99	95.88	94.73	94.70	95.90	93.59	95.21	95.93	95.61	91.99	93.97	94.85
Degree to which the medics listened to you and/or your family	97.78	94.31	93.63	93.77	94.52	96.88	94.22	94.75	96.11	95.60	92.11	94.80	95.44
Extent to which the medics kept you informed about your	95.45	91.96	92.92	91.76	92.33	92.75	92.56	93.81	94.98	94.69	91.33	94.04	94.26
Extent to which medics included you in the treatment decisions	95.36	93.77	92.86	92.01	93.16	91.71	93.93	91.47	96.68	93.34	89.66	93.44	92.69
Degree to which the medics relieved your pain or discomfort	94.74	87.89	87.94	87.43	92.54	90.17	86.22	92.90	91.13	91.12	89.07	90.92	90.45
Medics' concern for your privacy	97.44	94.31	95.39	97.16	96.00	96.73	94.72	93.45	95.85	94.40	92.26	95.53	94.51
Extent to which medics cared for you as a person	98.18	94.29	95.74	95.40	95.20	96.95	94.54	94.51	96.41	95.85	92.30	94.24	95.28
Professionalism of the staff in our ambulance service billing	92.86	90.00	95.00	81.25	93.18	96.43	100.00	87.50	97.22	96.88	94.44	100.00	94.57
Willingness of the staff in our billing office to address your	96.43	90.00	87.50	84.50	87.50	100.00	98.08	87.50	96.88	96.43	93.75	100.00	95.24
How well did our staff work together to care for you	98.54	94.99	96.22	96.25	95.72	96.68	95.92	95.98	97.79	96.46	93.02	95.22	94.78
Extent to which the services received were worth the fees	92.29	90.72	78.61	87.92	88.24	83.63	85.47	89.39	91.20	91.67	84.95	89.98	85.38
Overall rating of the care provided by our Emergency Medical	98.20	95.52	94.78	94.94	94.54	95.94	94.97	94.82	97.66	96.10	92.23	94.55	93.82
Likelihood of recommending this ambulance service to others	97.60	95.79	94.93	93.55	96.46	97.34	96.87	95.29	97.68	96.78	93.44	95.47	94.92
Your Master Score	96.91	94.00	94.07	93.80	94.57	95.33	93.86	94.19	96.02	95.12	91.82	94.44	94.18
Your Total Responses	150	150	150	144	150	150	150	150	150	150	150	150	150





Monthly tracking of Overall Survey Score

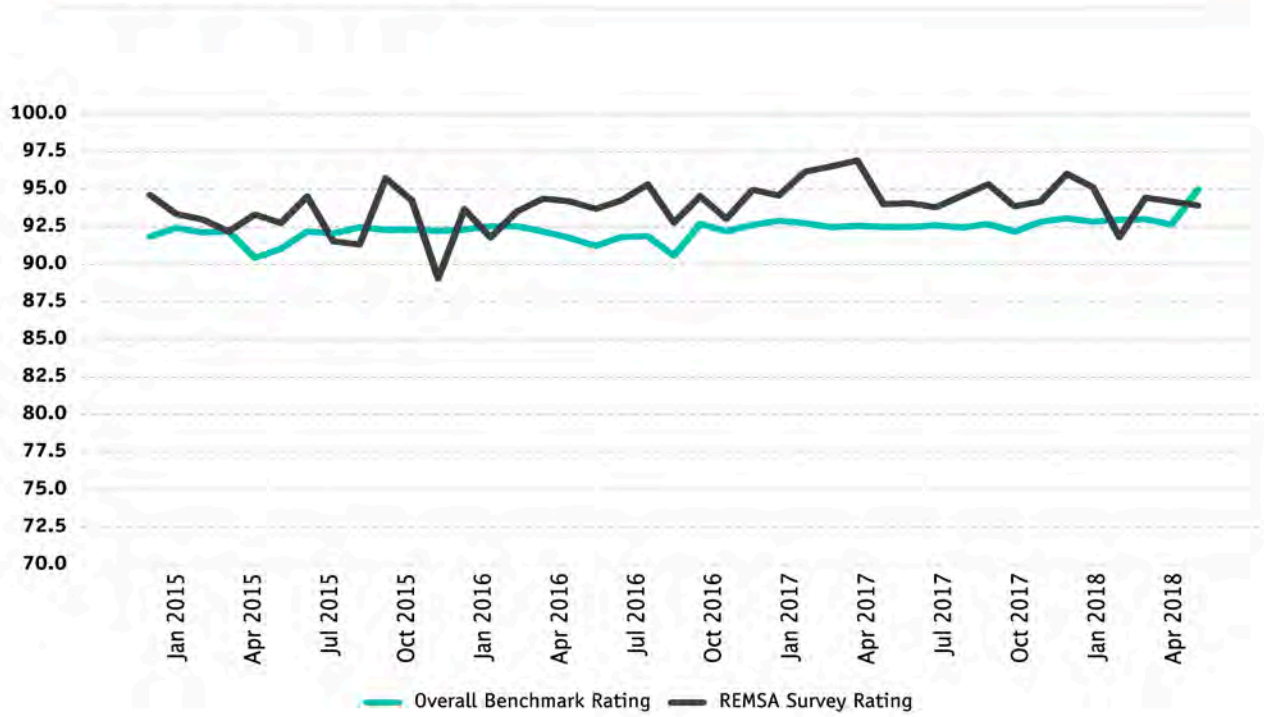



REMSA GROUND AMBULANCE APRIL 2018 CUSTOMER REPORT						
#	Date of Service	What Did We Do Well?	What Can We Do To Serve You Better	Description / Comments	Assigned to	Results After Follow Up
1	02/08/2018	"everything was wonderful, they did a really great job with my wife."				
2	02/08/2018	"they got here fast, were very caring, and seemed to know what they were doing. couldn't have asked for anything better"				
3	02/08/2018	"they here fast. it was a serious problem, and they really did well to manage my pain very well. I have a high pain tolerance, so it was very nice to know they knew what they were doing. they then got me to the hospital very quickly."				
4	02/10/2018	"they were truly great all around"				
5	02/11/2018	"yup all 5's for REMSA they're great!"				
6	02/13/2018	"Service was perfect."				
7	02/13/2018		"Yes. Medics need to appear more caring. They didn't talk or speak to me and show more compassionate. it's interesting how the health care system isn't very helpful or caring. Bring back humanity."		Assigned 5.4.18 #5623	5/5/18 I need to get the pts phone number, I will have the crew complete an occurrence report ASAP
8	02/14/2018	"I have always had good service with you guys."	"They didn't listen to me when I said to go to the back door. They should have listened. better communication with dispatch and medic."			
9	02/14/2018	"everything is great they get all 5's from me"				
10	02/14/2018	"yeah, they were great!"				
11	02/15/2018	"they were very caring"				
12	02/17/2018	"This experience really showed me and my family that REMSA actually cares about the patient. They helped my family and I through a difficult time. Compassionate"				
13	02/17/2018	"Taking care of me"	"Have them practice finding a vein"			
14	02/17/2018	"They just checked my vitals"				
15	02/16/2018		"They did fine"			
16	02/16/2018	"they got there in a timely manner, and took very good care of me. they also treated my with respect"				



REMSA GROUND AMBULANCE APRIL 2018 CUSTOMER REPORT						
#	Date of Service	What Did We Do Well?	What Can We Do To Serve You Better	Description / Comments	Assigned to	Results After Follow Up
17	02/16/2018	"I was not doing well at all that day, and they really took care of me."				
18	02/16/2018	"everything was done well, timely, explained what was going on the whole time. they were fantastic"				
19	02/16/2018	"they were really great both times! give them the highest markings!!"				
20	02/18/2018	"they got here quick, and were very caring"				
21	02/18/2018	"The medics were great!"				
22	02/18/2018	"Everything was fine."				
23	02/20/2018	"The two female medics were very awesome! They did just great"	"Called me when I was still in the hospital to set up payment arrangements. I feel that is disrespectful as I was still sick. But that's the only thing that I have to complain about."			
24	02/20/2018	"They treated me right and treated my family well also. They are all so great!"				
25	02/20/2018	"These people were so nice they were so nice to me."				
26	02/21/2018	"concerned about my pain level and did me very well. They cared."	"I have no complaints."			
27	02/21/2018	"air ride shocks like in moving trucks"				
28	02/21/2018		"Verbally abusive things said to Jordan @775- 335-7561 that were very discomforting and inappropriate"		Reassigned to Stacie due to incomplete follow up 5.4.18 #5572	5/5/18 1407, I left a message for PT to call about this complaint and give him my desk phone number. I will have the crew complete an occurrence report ASAP
29	02/21/2018	"The ambulance service was great! I'd give them a ten if I could. the hospital is another story. I was kick out."				
30	02/21/2018	"everything was good"				
31	03/01/2018	"they got here fast! when I asked to put my dog in the bathroom they helped put him in the bathroom. they did everything that was expected and more."				



REMSA GROUND AMBULANCE APRIL 2018 CUSTOMER REPORT						
#	Date of Service	What Did We Do Well?	What Can We Do To Serve You Better	Description / Comments	Assigned to	Results After Follow Up
32	03/01/2018	"they did everything well, they got here fast, and did everything they were supposed to"				
33	03/01/2018	"they did everything well"				
34	03/02/2018	"They got here quick, were very caring, and professional. They really did a great job."				
35	03/02/2018	"Mike and Ally were the medics names. Mike identified that I was in need of medical attention right away. Mike kept me reassured the entire time. They were on their A game. I am grateful."				
36	03/02/2018	"They did exactly what they needed during the snow storm."				
37	03/02/2018	"They did what they could."	"spilled coffee on the rug. More in negative feed back"		Assigned 4/24/18 #5605	Refer to #37 Results After Follow Up
38	03/02/2018	"everything"				
39	03/03/2018	"everything! they had great care and got here quick"				
40	03/02/2018	"they were quick, professional, and attended to my needs."				
41	03/03/2018	"it was all alright"				
42	03/03/2018	"Everything was good, they got me to the hospital, so yeah I give them a five."				
43	03/03/2018		"They kept trying to put an IV in me, when I kept telling them I am a hard stick, and would rather just go to the hospital. When they finally did get the IV in, it was in my foot, the medicine they were trying to give me I couldn't have. to a certain extent they need to listen to the patient!"		Assigned 5.4.18 #5625	Refer to # 43 Results After Follow Up
44	03/03/2018	"They have been to my house more than once, so when they do come out they already know what I can have and what I cannot have"	"Since they have been out to my house a couple times, they act like it's not a big deal. When it is a big deal, it is my life that is on the line. A couple of times they have asked me if I really want to go in. and those times I have been emitted to the hospital. I would like to be treated better."		Assigned 5.4.18 #4973	Refer to #44 Results After Follow UP
45	03/03/2018	"they were very quick"	"more comfortable beds"			
46	03/02/2018	"they did 1st aid very well"				
47	03/03/2018	"they were awesome"				
48	03/03/2018	"They did everything amazing, just amazing! I'd give them tens if I could"				



REMSA GROUND AMBULANCE APRIL 2018 CUSTOMER REPORT						
#	Date of Service	What Did We Do Well?	What Can We Do To Serve You Better	Description / Comments	Assigned to	Results After Follow Up
49	03/03/2018	"they were real quick. I told them I wasn't going to go to the hospital, but ended up changing my mind. they stayed the whole time while I made up my mind. that was really nice of	"they were a little dismissive in the ambulance and I wasn't really told what was going on"		Assigned 5.5.18 #5627	Phone call placed to patient, message left 5/7/2018 0915
50	03/04/2018	"they did their job"				
51	03/04/2018	"they paid attention to me very strongly"				
52	03/04/2018	"overall it was all exceptional"				
53	03/04/2018	"REMSA always does a good job for me."				
54	03/04/2018	"Very professional yet personable."				
55	03/04/2018	"They were asking me questions and answering my needs, they were really good to me."				
56	03/04/2018	"just everything, you guys actually care which is nice"				
57	03/05/2018	"I was in a lot of pain, but they got me and took care of me"				
58	03/05/2018	"everything was fine, they treated me very nice."				
59	03/05/2018	"they handled everything very well, and were very fast they were honestly excellent"				
60	03/05/2018	"I had asked the dispatch to not use sirens or be loud for privacy sake and they were very awesome about that. I really appreciated that!"	"Thank you very much for your services. I really appreciate your help!"			
61	03/06/2018		"Medics need more listening skills and better listen to patient about their pain level. They need to display sympathy and compassion."		Assigned 5.5.18 #5628	Refer to #61 Results After Follow Up
62	03/07/2018	"not a lot"	"be prompt, have the right things, and the right medicine."			
63	03/07/2018	"the care"				
64	03/07/2018		"I have had REMSA come out a couple times, and I know my problems. Overall they do a good job, I just wish they would listen to me more, so we can get things going faster"			
65	03/08/2018	"5"				
66	03/08/2018	"They treated me like someone special. I really appreciate that, thank you."				
67	03/15/2018	"""Thank you for the medics coming to me"""				
68	03/15/2018	"My son is non verbal and medics communicated very well to me."				



REMSA GROUND AMBULANCE APRIL 2018 CUSTOMER REPORT						
#	Date of Service	What Did We Do Well?	What Can We Do To Serve You Better	Description / Comments	Assigned to	Results After Follow Up
69	03/15/2018		"The experience was horrible. I was suicidal and the medics were rude, condescending and very judgmental."		Assigned 5.5.18 #5629	A message was left at the patient's listed telephone number on 5/7/2018 at 0945
70	03/15/2018	"Automotive system hung up three times."			Assigned 5.5.18 #5630	5/7/18 No answer, message left. We do not have an "automated" system. Will attempt to contact the complainant to clarify.
71	03/15/2018	"The skill level of care was very good."	"The male medic did not seem as concerned/didn't have the care level of the female medic. The female medic was more concerned with my care and well being, she seemed more understanding."			
72	03/16/2018	"They gave me the option to go with them or not. They also talked to me and calmed me down."	"Have water available."			
73	03/16/2018	"Their knowledge and professionalism when responding in the middle of the night during a snowstorm was remarkable."	"More comfortable gurney."			
74	03/16/2018	"They got there fast and did what they needed to do to get me to the hospital."				
75	03/16/2018	"everything was wonderful, couldn't have asked for better service"				
76	03/16/2018	"just everything"				
77	03/16/2018	"They were really great, couldn't have asked for better serve"				
78	03/17/2018	"just everything, they were great with the care they provided"				
79	03/16/2018	"overall they were fine"				
80	03/16/2018	"they were great, couldn't have asked for a better service"				
81	03/17/2018	"I mean everything they did was great, ya know"				
82	03/27/2018	"The medics were awesome."				
83	03/27/2018	"They were the best."				
84	03/27/2018	"I was treated very nicely by the medics and have nothing to complain about."				



REMSA GROUND AMBULANCE APRIL 2018 CUSTOMER REPORT						
#	Date of Service	What Did We Do Well?	What Can We Do To Serve You Better	Description / Comments	Assigned to	Results After Follow Up
<b>RESULTS AFTER FOLLOW UP</b>						
37	3/2/2018	After speaking to the patient I learned the missing meds and liner were from previous calls that we transported her. I explained that we would have most certainly taken the medications and prosthetic liner into the hospital with her upon arrival at the hospital. She said she has spoken to the hospital on numerous occasions and they have told her they don't have the items, and refer her to REMSA. As to the comment about the four ambulances and four fire trucks, the patient stated that it seemed like there were that many but she could not swear to it told the patient I will look back at her other charts in order to gain information regarding her missing property. I told her I will call her back with any new information.				
43	3/3/2018	5/5/18 1327, I spoke with the pt, he was unhappy with the crew as he told them he was a hard stick. Ptsaid they would not leave until they had a IV, they put one in his right foot and the hospital could not use it. I apologized the Pt and told him I would follow up with the crew, he thanked me for calling him. I will have the crew complete an occurrence report ASAP				
44	3/3/2018	5/5/18 1425, I called the pt, she told me she just talked to the lady for the survey and did not know when the date was and she was not really complaining. I asked if there were any problems with the REMSA crews and she told me no. I thanked her.				
61	3/6/2018	Telephone message left with patient 5/7/2018 0930 .A second call was placed to the patient's telephone at 1621 on 5/7/2018, but the voicemail box was full and I was unable to leave a message.				



# April 2018 Public Relations + Digital Media Highlights Report

District Board of Health

## PUBLIC RELATIONS

### Donate Life Month

REMSA and Donor Network West partnered to kick-off National Donate Life month in recognition of organ and tissue donation. Part of the celebration included recognizing Kyle Cobb, AEMT for his work on a call in 2011. The patient, a three-day-old infant, became the state's youngest organ donor. The patient's mother met Kyle for the first time since the day of the call. She thanked him for his efforts and presented him with a painting commemorating her daughter's organ donation and Kyle's role in her care.

Stories ran on KOLO, KTVN, KRNV, RGJ and on Donor Network West's social media and website.

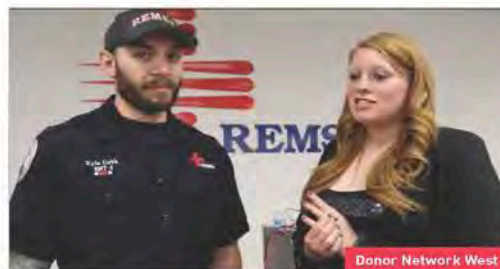

KRNV ran the story but did not post a link online.





## April 2018 Public Relations + Digital Media Highlights Report

*District Board of Health*

### PUBLIC RELATIONS

#### Amphetamine-Related Deaths in Nevada

Adam Heinz, Director of the Clinical Communications Center, provided an interview to KOL0 regarding the rise of amphetamine-related deaths in Nevada.





# April 2018 Public Relations + Digital Media Highlights Report

District Board of Health

## PUBLIC RELATIONS

### Telecommunications Week

National Telecommunications Week was celebrated with feature videos on Facebook that shared why telecommunications specialists are passionate about their work and what callers should expect when they dial 9-1-1 for a medical emergency. In addition, KTVN aired a feature story segment with interviews from Adam Heinz and Kenny Kitts.



# April 2018 Public Relations + Digital Media Highlights Report

District Board of Health

## PUBLIC RELATIONS

### Telecommunications Week (Continued)

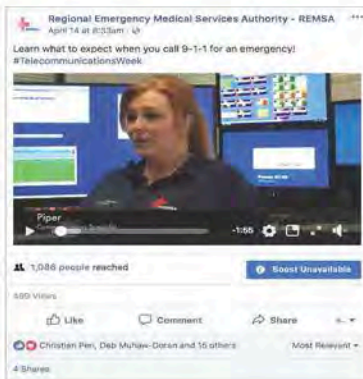

### Emergency Services

Dean Dow is quoted in the article, "Uber to the ER?," in *Governing* magazine. The article addresses the need to educate people on when to use and when not to use 9-1-1, as well as giving people alternate numbers for non-emergency situations.





# April 2018 Public Relations + Digital Media Highlights Report

District Board of Health

## PUBLIC RELATIONS

### Congratulations Jeff Pierce, ECN of the Year

Jeff Pierce, RN, Nurse Navigator, joined REMSA's Nurse Health Line team in 2016. His vast clinical experience, professionalism, collaboration, and commitment to recommending a safe and appropriate level of care to callers using the Nurse Health Line, earned him a nomination from his colleague, Debra Aschenbrenner, RN. Debra had this to say in Jeff's nomination form: "Jeff always shows concern for the caller. He conducts calls in a consistent, calm and supportive manner. Jeff is a leader on our team, demonstrates a commitment to the standards of our program and represents the Nurse Health Line to our callers in the best possible manner. Jeff shows, every day, his compassion for the caller in need."

Jeff was honored at this year's Navigator conference with the Bill Boehly Award for Emergency Communication Nurse of the Year.

Congratulations, Jeff! Every day, your contributions support our organization's mission - contributing to the health of the communities we serve through compassion, innovation and patient-centered care.

EMS1 and International Fire Buyer covered the awards.

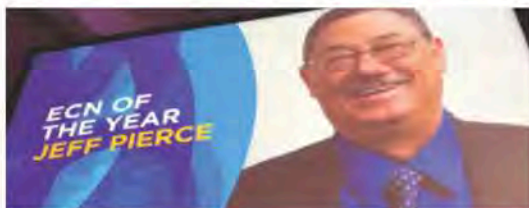



# April 2018 Public Relations + Digital Media Highlights Report

District Board of Health

## PUBLIC RELATIONS

### Point of Impact

The April Free Car Seat Checkpoint was posted on several calendar listings.

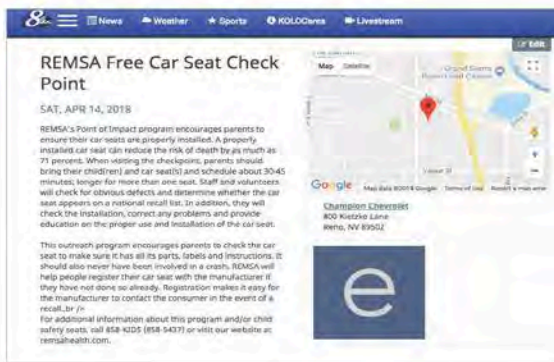



# April 2018 Public Relations + Digital Media Highlights Report

District Board of Health

---

## SOCIAL MEDIA HIGHLIGHTS

---

### REMSA Social Media

Social media performance this month was the best to date, and we are incredibly thrilled with the ongoing results this effort is bringing. In particular, the video content developed and posted by REMSA has had outstanding performance, with each post's reach in the thousands. Social media engagement is such an important element of a public relations program, and we plan to continue the momentum with engaging content and new ways of telling the REMSA story through these social channels while exploring new opportunities.

### Facebook

- **Likes to-date:** 2,333
- **Followers to-date:** 2,255
- **April posts:** 32
- **April post comments:** 200
- **April post shares:** 126
- **April post reactions:** 1.73k

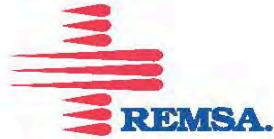

# April 2018 Public Relations + Digital Media Highlights Report

District Board of Health

## SOCIAL MEDIA HIGHLIGHTS

### Top Posts By Reach

#### 1. REMSA Telecommunications

- 2,967 people reached
- 1,523 video views
- 256 reactions, comments and shares

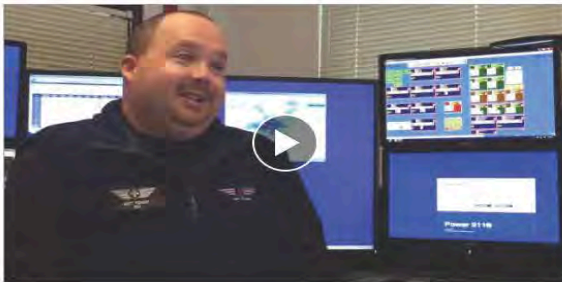

**Regional Emergency Medical Services Authority - REMSA: REMSA Telecommunications**

Hear from Christine, Matt and Piper about why they love working in telecommunications at REMSA. #TelecommunicationsWeek

1:14 · Uploaded on 04/11/2018 · View Permalink

#### 2. Reno Aces Opening Night

- 2,379 people reached
- 1,161 video views
- 160 reactions, comments and shares

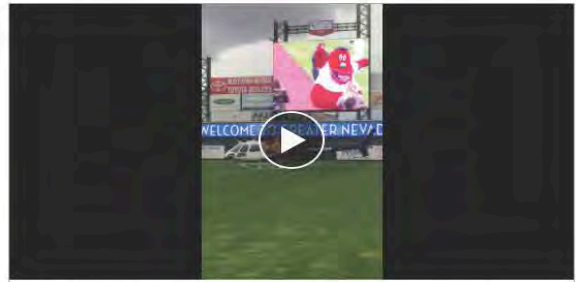

**Regional Emergency Medical Services Authority - REMSA**

Opening night for Reno Aces. REMSA / Care Flight is proud to fly in Archie to the Greater Nevada Field

1:32 · Uploaded on 04/05/2018 · View Permalink

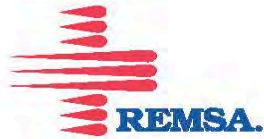

# April 2018 Public Relations + Digital Media Highlights Report

District Board of Health

## SOCIAL MEDIA HIGHLIGHTS

### LinkedIn

- **Followers to-date:** 917
- **Posts:** 6
- **Impressions:** 2,465
- **Clicks:** 87
- **Social Actions:** 53

### Top Post By Impressions

 **REMSA**  
2w

Thank you **KTVN Channel 2 News** for visiting REMSA last week to celebrate Telecommunications Week.



**REMSA Recognizes Dispatchers During Telecommunications Week**  
ktnv.com

12 Likes

 Like  Comment

Organic Reach: 677 Impressions Show stats 

### April Website Referral Sessions from Social Media

Website referral sessions from social media have increased 578.43% year over year. Increase in sessions in April can be attributed to Facebook, LinkedIn and YouTube.





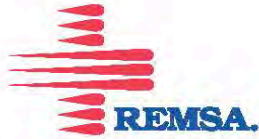

# April 2018 Public Relations + Digital Media Highlights Report

District Board of Health

## GOOGLE ANALYTICS

### REMSA Google Analytics

We use Google Analytics to measure the various ways visitors come to the website. The best way we can measure how public relations is driving people to the REMSA website is to evaluate referral and direct traffic. Referral traffic is Google's method of reporting visits that came to your site from sources outside of its search engine, i.e. a partner website, news website, etc. Direct traffic are users who directly type your URL or visit through a bookmarked mechanism. Direct traffic can be related to brand awareness, as well.

Direct traffic year over year in the month of April increased by 1%. The bounce rate which determines how many people visited the website without any interactions decreased by 40% and the average number of pages viewed increased by 41%.

#### Overall Site Sessions in April (Year over Year Comparison)

Overall, the new website is performing great in all areas in Google Analytics:

- **Sessions:** 27% decrease year over year
- **Users:** 9% increase year over year
- **Pageviews:** 7% decrease year over year
- **Pages / Session:** 27% increase year over year
- **Avg. Session Duration:** 8% decrease year over year
- **Bounce Rate:** 19% decrease year over year

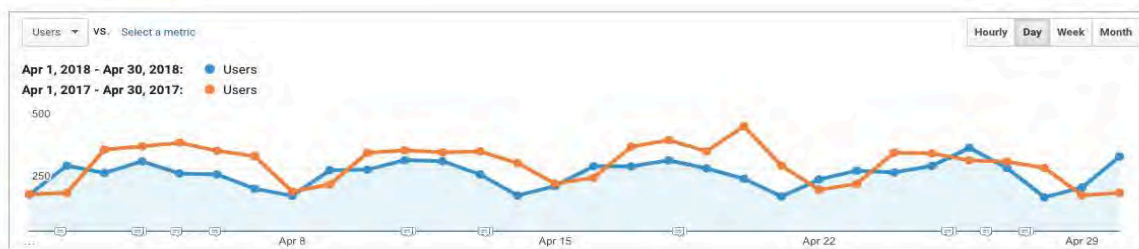

# April 2018 Public Relations + Digital Media Highlights Report

District Board of Health

GOOGLE ANALYTICS

## Referral Traffic:

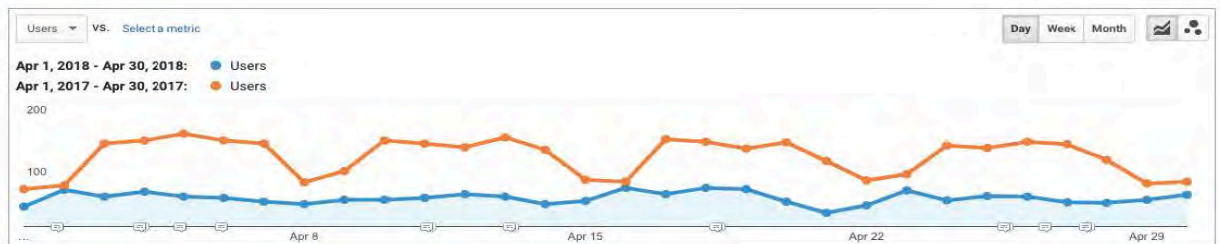

## Direct Traffic:





**REMSA 2017-18 PENALTY FUND RECONCILIATION AS MARCH 31, 2018**

**2017-18 Penalty Fund dollars accrued by month**

<u>Month</u>	<u>Amount</u>
July 2017	\$6,510.60
August 2017	6,275.80
September 2017	9,269.04
October 2017	7,060.72
November 2017	6,271.88
December 2017	8,733.88
January 2018	7,279.84
February 2018	8,018.44
March 2018	8,407.16
April 2018	
May 2018	
June 2018	
<b>Total accrued as of 3/31/2018</b>	<b><u>\$67,827.36</u></b>

**2017-18 Penalty Fund dollars encumbered by month**

<u>Program</u>	<u>Amount</u>	<u>Description</u>	<u>Submitted</u>
Child Safety	\$5,965.00	500 First Aid Kits for children's league sports	January-18

**Total encumbered as of 3/31/2018** **\$5,965.00**

**Penalty Fund Balance at 3/31/2018** **\$61,862.36**



## **REMSA INQUIRIES**

**APRIL 2018**

No inquiries for April 2018

**AIR QUALITY MANAGEMENT  
DIVISION DIRECTOR STAFF REPORT  
BOARD MEETING DATE: May 24, 2018**

**DATE:** May 11, 2018  
**TO:** District Board of Health  
**FROM:** Charlene Albee, Director  
775-784-7211, calbee@washoecounty.us  
**SUBJECT:** Program Update, Divisional Update, Program Reports

---

**1. Program Update**

- a. EPA Publishes Initial Designations for the 2015 Ozone National Ambient Air Quality Standard

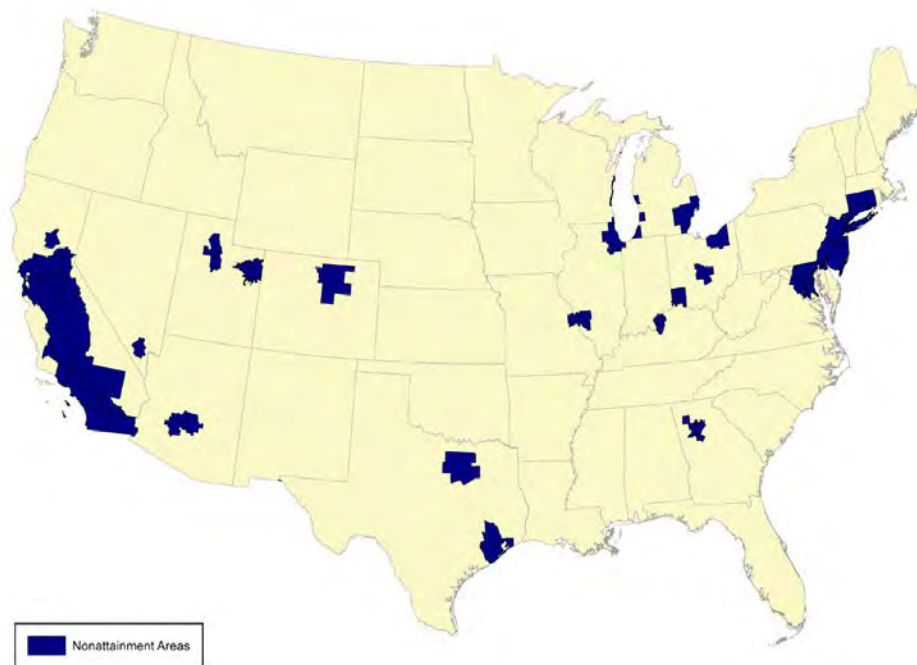

On May 1<sup>st</sup>, the U.S. Environmental Protection Agency (EPA) published the initial 2015 Ozone National Ambient Air Quality Standards (NAAQS) designations for a majority of the remaining areas of the country that were not previously designated in November

2017. The only exception is eight counties in the San Antonio, Texas area which will be designated in July 2018. As identified on the map, the only area in Nevada to be designated nonattainment is a portion of Clark County which has been classified as marginal, meaning the design value is from 0.71 parts per million (ppm) and up to but not including 0.081 ppm. As previously reported, the attainment designation for Washoe County was made possible with EPA's concurrence on the Ozone Wildfire Exceptional Events Demonstrations submitted for 2015 and 2016. The ozone design value for Washoe County is currently at 0.070 ppm which equals the 2015 ozone NAAQS.

With the publication of the official attainment designations, AQM staff will now be challenged with increasing the focus on the



implementation of the Ozone Advance Program Path Forward in order to maintain the designation. Each of the goals and associated strategies included in the Path Forward will be critically important as the community continues to grow. Whether addressing near-term goals with an emphasis on behavior and technology or long-term goals encouraging improvements in land use patterns, AQM staff will be reaching out to everyone in the community to do their part to help ***Keep it Clean.***

Charlene Albee, Director  
Air Quality Management Division

## 2. Divisional Update

- a. Below are two charts detailing the most recent ambient air monitoring data. The first chart indicates the highest AQI by pollutant and includes the highest AQI from the previous three years in the data table for comparison. The second chart indicates the number of days by AQI category and includes the previous year to date for comparison.

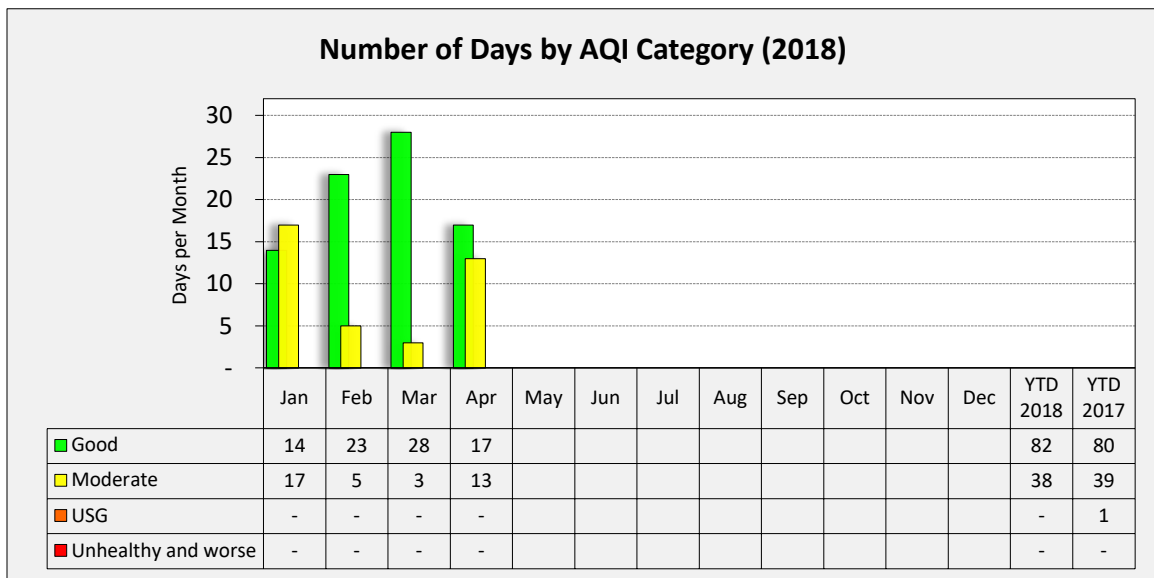
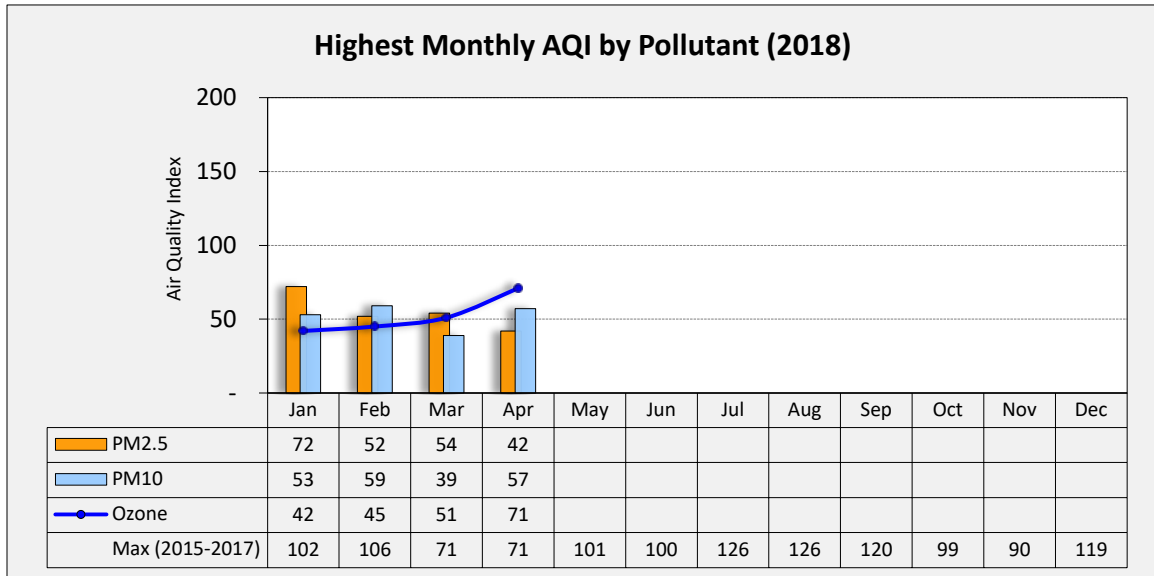

Please note the ambient air monitoring data are neither fully verified nor validated and should be considered PRELIMINARY. As such, the data should not be used to formulate or support regulation, guidance, or any other governmental or public decision. For a daily depiction of the most recent ambient air monitoring data, visit [OurCleanAir.com](http://OurCleanAir.com).

### 3. Program Reports

#### a. Monitoring and Planning

April Air Quality: There were no exceedances of any National Ambient Air Quality Standard (NAAQS) during the month of April.

Educating and Empowering Local Leaders: The success of Ozone Advance relies on voluntary programs to improve air quality. The built environment determines our transportation choices, vehicle miles traveled (VMT), and ozone levels. Ever since the DBOH adopted a resolution in 2016 supporting Ozone Advance, AQM has been educating and empowering our local leaders to include public health in the decisions that shape our built environment. It began with top-down support through resolutions supporting Ozone Advance adopted by the City of Reno, City of Sparks, Board of County Commissioners, Regional Transportation Commission, and Regional Planning Governing Board. AQM has also been highlighting the relationship between the resolutions with Ozone Advance goals, strategies, and priorities.

The key region-wide plans supporting Ozone Advance are the: 1) Regional Plan, and 2) Regional Transportation Plan. These plans guide our land use patterns which impacts our VMT and urban heat island. Incorporating Ozone Advance goals into these plans also provides our local jurisdictions the tools and ability to ensure future development will maintain our healthy community. The following figure illustrates how top-down support leads to great projects and programs.

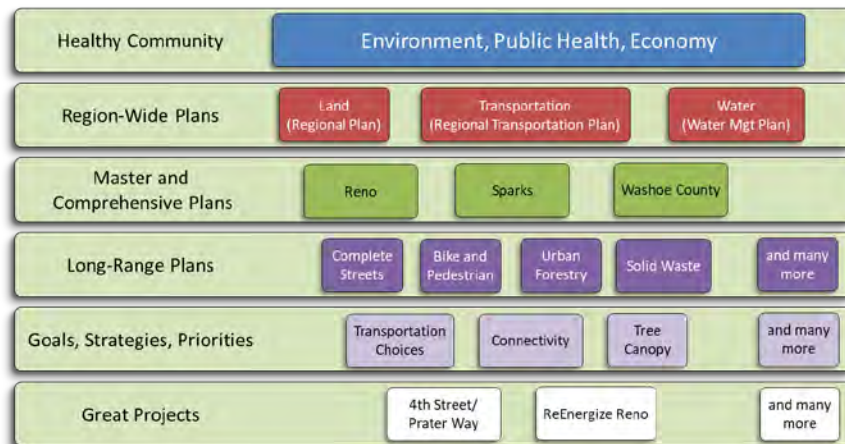

Daniel K. Inouye  
Chief, Monitoring and Planning



b. Permitting and Enforcement

Permitting staff reviewed forty (40) sets of plans submitted to the Reno, Sparks or Washoe County Building Departments to assure the activities complied with Air Quality requirements.

- Enforcement staff has successfully recruited a new Air Quality Trainee, Brittney Osborn, who will start with AQMD on May 29th. She is currently supervising inmate crews for the Nevada Division of Forestry.

Enforcement staff conducted thirty-four (34) stationary source inspections, fourteen (14) gasoline stations and seven (7) initial compliance inspections in April 2018. Staff was also assigned oversight of five (5) new asbestos-related projects and six (6) new demolition projects. There were also twelve (12) new construction/dust projects to monitor; additionally twenty-two (22) construction site inspections were documented. Each asbestos abatement, demolition notification and construction project is monitored regularly until such time as each project is complete and the permit is closed. During the month enforcement staff also responded to sixteen (16) complaints.

Type of Permit	2018		2017	
	April	YTD	April	Annual Total
<b>Renewal of Existing Air Permits</b>	92	364	88	1055
<b>New Authorities to Construct</b>	5	22	8	60
<b>Dust Control Permits</b>	11 (142 acres)	66 (1151 acres)	16 (141 acres)	173 (2653 acres)
<b>Wood Stove (WS) Certificates</b>	28	129	20	474
<b>WS Dealers Affidavit of Sale</b>	2 (2 replacements)	44 (29 replacements)	5 (4 replacements)	54 (40 replacements)
<b>WS Notice of Exemptions</b>	719 (13 stoves removed)	2632 (31 stoves removed)	490 (7 stoves removed)	9722 (88 stoves removed)
<b>Asbestos Assessments</b>	84	379	104	1029
<b>Asbestos Demo and Removal (NESHAP)</b>	25	93	16	241

COMPLAINTS	2018		2017	
	April	YTD	April	Annual Total
<b>Asbestos</b>	1	4	2	13
<b>Burning</b>	0	1	0	10
<b>Construction Dust</b>	7	13	3	42
<b>Dust Control Permit</b>	0	0	0	2
<b>General Dust</b>	4	14	5	54
<b>Diesel Idling</b>	1	5	0	0
<b>Odor</b>	3	13	0	15
<b>Spray Painting</b>	0	1	2	11
<b>Permit to Operate</b>	0	3	0	3
<b>Woodstove</b>	0	3	0	7
<b>TOTAL</b>	<b>16</b>	<b>57</b>	<b>12</b>	<b>157</b>
NOV's	April	YTD	April	Annual Total
<b>Warnings</b>	3	4	0	10
<b>Citations</b>	0	0	1	7
<b>TOTAL</b>	<b>3</b>	<b>4</b>	<b>1</b>	<b>17</b>

\*Discrepancies in totals between monthly reports can occur due to data entry delays.

Mike Wolf  
 Chief, Permitting and Enforcement

DD_SK	_____	_____
DHO	_____	_____

**Community and Clinical Health Services  
Director Staff Report  
Board Meeting Date: May 24, 2018**

**DATE:** May 7, 2018  
**TO:** District Board of Health  
**FROM:** Steve Kutz, RN, MPH  
775-328-6159; skutz@washoecounty.us  
**SUBJECT:** **Program Report** – Teen Pregnancy Prevention Month; Divisional Update –Client Satisfaction Survey Results; Nevada Childhood Lead Poisoning Prevention Program; Data & Metrics; Program Reports

---

**1. Program Report – May is National Teen Pregnancy Prevention Month**



According to The National Campaign to Prevent Teen and Unintended Pregnancy there has been a steep decline in the teen pregnancy rate in the United States since 1991. The United States has experienced a 67% decline in the teen birth rate since 1991. Likewise, Nevada has also seen a significant decrease in both the teen pregnancy and teen birth rate. From 1991 to 2016 the teen birth rate in Nevada declined by 68% and the teen pregnancy rate from 1998 to 2013 declined 66%. Following the state and national trend, Washoe County has also experienced a drop in the teen birth rate.

**Fig. 8 Teen Birth Rate Females 15-19 years, Washoe County, Nevada, & the United States, 2009-2016**

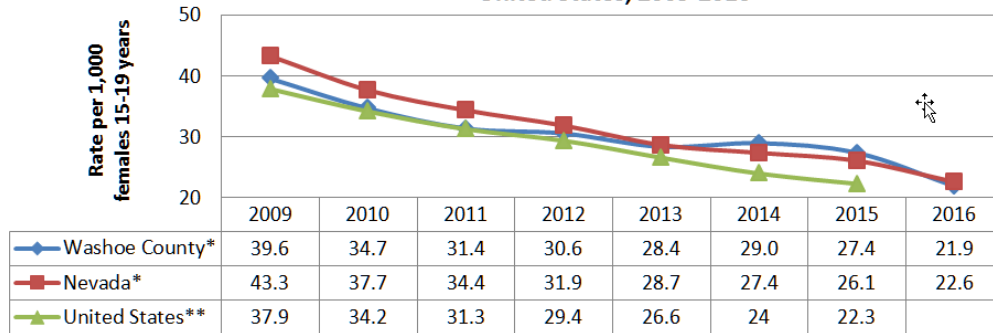

This downward trend in the teen pregnancy rate leaves a positive impact on the teens themselves as well as the communities they live in. The National Campaign to Prevent Teen and Unintended Pregnancy states preventing teen pregnancy reduces poverty, improves a teens lifelong income, increases the graduation rate, improves health and child welfare, supports responsible fatherhood, and reduces other risky behavior. Additionally, in 2015 it is estimated that the state of Nevada saved \$29 million due to the falling teen birth rate.

The reasons for the drop in the teen pregnancy rates are multifactorial and include increased access to sexual health information, increased access to contraception, and less risky sexual behavior by teens. According to the 2015 Nevada High School Youth Risk Behavior Report (YRBS) 40.1 % of those surveyed had ever had sex and 27% of those surveyed were sexually active (sexual activity in the 3 months prior to survey). This compares to 2013 when 43.8% reported ever having sex and 29.2% who were sexually active. Increased access to birth control is also reflected in the YRBS survey. In 2015 87.6% of teens surveyed reported use of some form of contraception at their last sexual encounter. This is an increase from 2013 when 84% of teens surveyed reported the use of some form of contraception at their last sexual encounter.

While the teen birth rate continues to decrease, there are still areas for improvement to ensure the trend continues in both the teen birth and teen pregnancy rate. As of 2015 (latest year for which data is available), Nevada ranks 37 out of 50 states for the teen birth rate and 41 out of 50 states for the teen pregnancy rate. In Nevada, the majority of teen births are to older teens (18-19 year olds). However, the repeat teen birth rate in Nevada remains an area for improvement. It is estimated that 17% of the teen births were to teens who already had a child. Access to confidential services for sexual and reproductive health for teens also remains a barrier and an area for improvement. Confidentiality concerns are a significant issue to teens with 1 in 5 teens aged 15-17 reporting that they would not seek sexual and reproductive health care because of

concerns that their parents may find out. In one survey, only 22% of teens aged 15-17 years old with confidentiality concerns had received contraceptive services in the prior year.

CCHS, specifically the Family Planning Clinic, Teen Health Mall, and Sexual Health Program, continues to strive to provide teens with education and access to confidential services to promote sexual and reproductive health. The Community Needs Assessment highlighted the need for more outreach in the high risk zip codes. As part of that outreach the Family Planning Clinic currently advertises in the school newspapers at Hug High School and Wooster High School. In collaboration with the Sexuality, Health, and Responsibility Education (SHARE) program, students at Wooster High School are given presentations regarding birth control, pregnancy options, and sexual health. In February 2018, the Family Planning program developed an Epi-News regarding long acting reversible contraceptives (LARCs). One of the goals of this issue was to dispel the myth that LARCs are not appropriate for teens and educate local providers about the safety and efficacy of LARCs when used in the teen population.

As a federally funded family planning clinic the provision of confidential services is key to the continued decline in the teen pregnancy rate. Although services are confidential, family involvement is always encouraged. It is estimated that the teen pregnancy rate would have been 73% higher without federally funded family planning programs. Although we focus on Teen Pregnancy Prevention in May, CCHS works to prevent teen pregnancy all year long.

## 2. Divisional Update

- a. **Client Satisfaction Survey Results 2018** – In February 2018 CCHS conducted its annual “Client Satisfaction Survey”, with 384 completed surveys across six programs. Detailed in the summary chart below, both 2017 and 2018 results were overwhelmingly positive with the majority of clients ranking CCHS clinical services “good” or “great”, as has been the case over the past few years. Changes from 2017 to 2018 include an increase in satisfaction for ease of getting care, front desk staff, and the facility; slight decreases were noted in the areas of wait time, staff/provider, and confidentiality. Additional client comments on the survey were overall positive, speaking mostly to the quality of staff and ease of access to our location.

CCHS Client Satisfaction Survey Results - 2018 Compiled		2017 Results n= 245	2018 Results n= 384
Category & Question		Good/Great %	Good/Great %
<b>Ease of Getting Care</b>			
Scheduling an appointment		92%	95%
Time between making an appointment and being seen		90%	95%
Convenience of clinic hours		93%	91%
Convenience of clinic location		93%	93%
<b>TOTAL Overall Satisfaction</b>		<b>92%</b>	<b>94%</b>
<b>Wait time</b>			
Time in waiting room		89%	90%
Time in exam room		94%	91%
Height/weight and nutrition education (WIC only)		93%	83%
Receive benefits and next appt. paperwork (WIC only)		92%	92%
<b>TOTAL Overall Satisfaction</b>		<b>92%</b>	<b>89%</b>
<b>Front Desk Staff</b>			
Courtesy of staff		94%	96%
Clearly request documents needed at check in		89%	97%
Answers your questions		95%	97%
<b>TOTAL Overall Satisfaction</b>		<b>93%</b>	<b>97%</b>
<b>Staff/Provider</b>			
Courtesy of clinic staff		97%	97%
Clinic staff listens to you		97%	98%
Clinic staff takes enough time with you		97%	97%
Clinic staff clearly answers your questions		97%	97%
Helped you to find a birth control method that works well for you (MCH, FP, TB, and Sexual Health only)		n/a	93%
<b>TOTAL Overall Satisfaction</b>		<b>97%</b>	<b>96%</b>
<b>Payment</b>			
What you pay		79%	84%
Explanation of charges		82%	86%
<b>TOTAL Overall Satisfaction</b>		<b>81%</b>	<b>85%</b>
<b>Facility</b>			
Cleanliness of clinic		94%	98%
Ease of finding where to go		89%	92%
Comfort while waiting		94%	95%
<b>TOTAL Overall Satisfaction</b>		<b>92%</b>	<b>95%</b>
<b>Confidentiality</b>			
Keeping your personal information private		96%	92%
<b>TOTAL Overall Satisfaction</b>		<b>96%</b>	<b>92%</b>

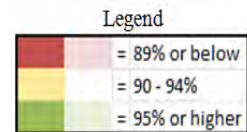

In 2018, client satisfaction was ranked highest for front desk staff, the staff/provider, and the facility. Facility enhancement is a Health District Strategic Plan Initiative, and it appears that efforts toward improvements are paying off in this area. The most significant improvement from 2017 to 2018 was with front desk staff, where satisfaction increased from 93% to 97%. The vast majority of client comments were positive, expressing enthusiasm for the friendliness of staff, clinic affordability, and location.

Appointment scheduling and being able to quickly get an appointment continues to improve. We believe that the implementation of our phone queue system has helped in this area. Increasing the number of health plans with whom we are contracted may also help increase satisfaction with regards to payment.

Potential areas for improvement include wait time and ensuring clients are better informed regarding the safeguards in place to protect their confidentiality.

Overall, positive survey responses and favorable client comments exemplify the success of CCHS clinic services. Clients expressed their happiness with the services and staff, feeling comfortable and confident in their care within CCHS.

- b. **Nevada Childhood Lead Poisoning Prevention Program (NCLPPP)** – NCLPPP's mission aims to reduce the long-term health risk of childhood lead poisoning through improved methods of surveillance, education and intervention. The Advisory Committee, of which I have been added as a member, meets quarterly. The committee will provide input on ways to increase the number of children less than six years old who are screened for lead; strengthen surveillance efforts; strengthen population based interventions; and strengthen the linkage to care of affected children.

c. Data/Metrics

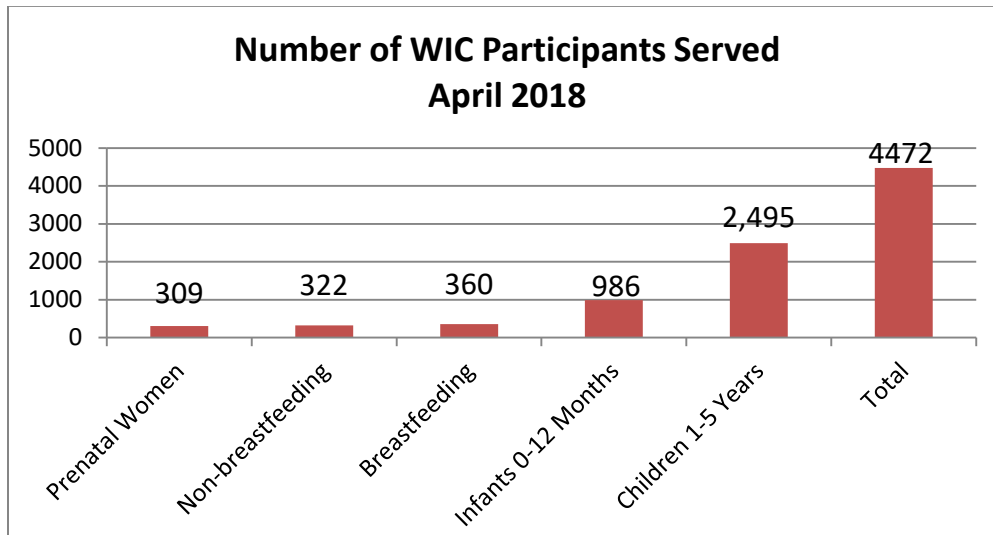
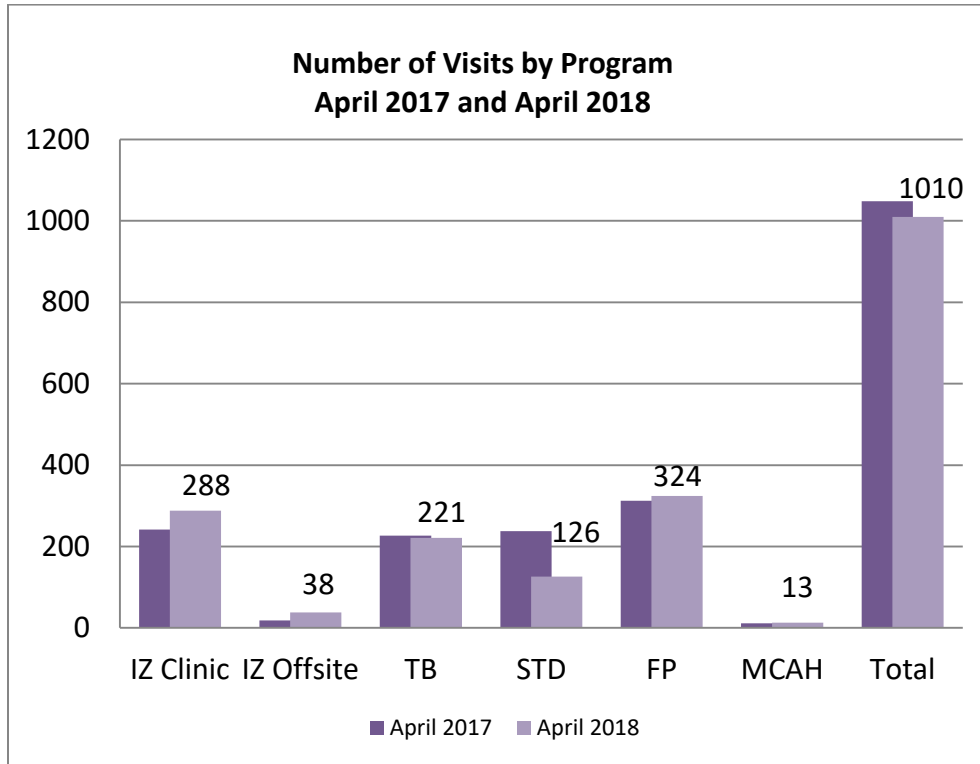

Changes in data can be attributed to a number of factors – fluctuations in community demand, changes in staffing and changes in scope of work/grant deliverables, all which may affect the availability of services.



### 3. Program Reports – Outcomes and Activities

- a. **Sexual Health** – Staff conducted SHARE presentations for six classes (approximately 75 students) at a local High School in April. Presentations included information on safer sexual practices such as abstinence, condom use, and answering student's questions. Staff are also conducting SHARE presentations are also planned for a local trade school for two classes (approximately 40 students), focusing on the same topics.
- b. **Immunizations** – Linnie Shore, RN, was honored at the 20<sup>th</sup> Annual Silver Syringe Awards as the "Outstanding Immunization Nurse" for Northern Nevada on April 19, 2018. Staff also participated in the Community Baby Shower event on April 28, 2018 at Meadowood Mall to celebrate National Infant Immunization Week, in partnership with Immunize Nevada. Staff administered 29 doses of vaccine to 22 participants.

Our Public Health Associate, Sophie Banspach, had her abstract entitled "School Location Vaccination Clinics: An Analysis of Clinic Trends and Implications for the Washoe County School Located Vaccination Program" accepted by the CDC for presentation at the 2018 Public Health Associate Program's Mid-Program Training in June 2018.

- c. **Tuberculosis Prevention and Control Program** – Program staff hosted a meet and greet session between CDC's Regional TB Consultant and the State TB Controller, last month. The group discussed national TB issues such as funding and attitudes concerning mandatory reporting of Latent TB Infection (LTBI), and their impact on local health authorities. TB staff and management recently met with Renown Regional Medical Center Infection Control, Intervention Radiology physicians, and Jaime Frank, Nevada State Public Health Lab, to begin a dialog regarding the collection of biopsy specimens viable for the cultures and subsequent sensitivities and genotyping of TB strains. An understanding of the needs and concerns of involved parties was obtained. Renown Infection Control will explore the possibility of adding a risk assessment specifically for TB to pre-op paperwork to support the collection of specimens in saline when TB infection is suspected. Specimens placed in formalin are rendered unusable for the diagnosis of TB infection. Currently the TB program is following 7 clients for direct observation therapy (DOT); 3 finishing up treatment from 2017 and 3 active cases diagnosed in 2018.
- d. **Family Planning/Teen Health Mall** – Related to the program report above, a press release will go out to promote Teen Pregnancy Prevention month. Staff have posted teen pregnancy prevention information on the Health District website, Facebook and Twitter.

Staff provided family planning information at the SHARE presentations referenced in the Sexual Health report above.

- e. **Chronic Disease Prevention Program (CDPP)** – Staff attended the Northern Nevada Opioid Awareness Summit, and has joined the Community Opioid Response Alliance to assist in leveraging alternative therapies for chronic pain management in our community.

Staff provided public comment in coordination with community partners related to the health benefits of smoke free parks (includes trails and open spaces) at the Reno and Sparks City Council meetings as well as the Washoe County Commission. All three jurisdictions voted to move forward with smoke free parks, and staff will continue to provide technical assistance as the entities move through the process of developing ordinance language and taking a vote on adoption.

CDPP staff facilitated a media campaign that is promoting smoke free locations. The campaign is running on TV, radio and social media and has ads in both English and Spanish. As with previous campaigns, coordination took place with Carson City Health and Human Services to combine efforts in order maximize reach of messaging in our geographic area. The campaign began in April and will continue into June.



With the help of neighborhood youth, CDPP staff, the Housing Authority of the City of Reno (RHA) and artist Erik T. Burke collaborated to create a healthy living-themed mural on a retaining wall on East 10th St. in Reno. The mural highlights smoke-free housing, healthy eating and physical activity. An unveiling ceremony was held on May 3<sup>rd</sup> with representation by local and State dignitaries.

- f. **Maternal, Child and Adolescent Health (MCAH)** – Linda Gabor was selected to participate on the Nevada Maternal and Child Health Advisory Board. Staff participated in a National Institute for Children's Health Quality (NICHQ) Safe Sleep webinar on April 25, 2018. A Fetal Infant Mortality Review (FIMR) Program Site Visit by the State of Nevada Department of Public and Behavioral Health was successfully completed on April 25, 2018.
- g. **Women, Infants and Children (WIC)** – The WIC team is excited to announce that Maria Rodriguez has been promoted to a Human Services Support Specialist II. Maria has been serving clients in the WIC program for eleven years.

DD	CW
DHO	KD

**Environmental Health Services  
Division Director Staff Report  
Board Meeting Date: May 24, 2018**

**DATE:** May 11, 2018  
**TO:** District Board of Health  
**FROM:** Chad Warren Westom, Director  
775-328-2644; [cwestom@washoecounty.us](mailto:cwestom@washoecounty.us)  
**SUBJECT:** Environmental Health Services (EHS) Division and Program Updates – Child Care, Community Development, Food, Land Development, Safe Drinking Water, Schools, Vector-Borne Disease and Waste Management

---

**Division Updates**

- Two new staff joined us on Monday May 14. Congratulations to our very own Kristen deBraga on her acceptance of a full-time Environmental Health Specialist (EHS) Trainee position. She will be reporting to Tony Macaluso. We also have Tyler Henderson joining us as an EHS Trainee, reporting to Jim English. Tyler has a diverse work and educational background and most recently has had law enforcement instructor responsibilities in the Nevada Prison system. The EHS Division is now fully staffed, but since the workload demand remains high, we will also recruit for our part-time pooled position and intern vacancies.
- The EHS Division launched 2018 with a strong start, with set priorities and clear expectations. We saw a dramatically increased number of inspections in first quarter of 2018; over 2000 of them were completed.
- The Division is enrolled in the FDA Voluntary National Retail Food Regulatory Program Standards. The FDA Standards specify that Washoe County should be inspecting Risk Level III Food Establishments at least three times per year. Examples of Risk Level III food establishments include full service restaurants, continuous operation casino/resort kitchens, buffets, manufacturers of potentially hazardous food and caterers serving potentially hazardous food. Therefore, we have been positioning the Division to be able to inspect Washoe County restaurants a second time in the fall or winter of 2018. The EHS fees, adopted in 2015, were calculated to include only one food establishment inspection per year. For now, we will make use of the Division’s \$180 Re-Inspection fee (as of July 1, 2018), payable either at renewal or at time of inspection. Meetings and conversations have been conducted with restaurants and casinos regarding this new direction, including the Nevada Restaurant Association, Great Basin Brewery, the Peppermill, BJ’s Nevada BBQ Co., Circus Circus, Silver Peak, PJ & Company, Grand Sierra, and BJ’s Restaurant & Brewhouse. All expressed support. Per the Health District mission,

this initiative will help protect residents and visitors from dangerous conditions at non-compliant restaurants. It will also provide added assurance to the entire restaurant and casino industry of Washoe County. It is a firm step in the right direction to meet more requirements of the FDA Food Program Standards.

- **Environmental Health Services Training Program** – By mid-April all EHS field staff completed training for school inspections. A final presentation was given for staff during a bi-weekly meeting and staff is now doing school inspections regularly as part of their assigned areas.
- **Environmental Health Services Epidemiology Program** – During the month of April, Environmental Health Services (EHS) Epidemiology program staff worked with Communicable Disease (CD) program staff to investigate potential Measles exposures in several individuals. Six employees of a local restaurant who may have been potentially exposed to a known case were interviewed by EHS staff.

In mid-April EHS staff conducted an investigation of a case of Salmonella Thompson from an individual who consumed kratom (an herb that is sold in smoke shops and other locations and is known for its opioid effect). The investigation was prompted by nationwide recalls for kratom due to Salmonella cases. The pattern of infection from the case matched the nationwide recall. Several pounds of kratom were put on hold in two different locations and samples collected for Salmonella testing. The samples were negative and by the beginning of May the Centers for Disease Control had halted the investigation. The local hold orders were lifted and one sample was released back to sale and the other as part of a recall was returned to the distributor. As of the end of April no new cases were reported and the case initiated by EHS and the CD program was closed.

**Program Updates**

**Child Care**

- Child care staff from EHS worked with Washoe County Social Services (WCSS) on licensing three separate facility expansions and a new child care facility in April.

**Community Development**

- Please see the table below for the specific number of plans per program, inspections and the number of lots or units that were approved for construction within Washoe County:

<b>Community Development</b>	<b>JAN 2018</b>	<b>FEB 2018</b>	<b>MAR 2018</b>	<b>APR 2018</b>	<b>YTD 2018</b>	<b>2017 TOTAL</b>
Development Reviews	44	48	49	45	186	426
Commercial Plans Received	75	76	86	65	302	780
Commercial Plan Inspections	23	16	26	23	88	407
Water Projects Received	27	29	23	25	101	287
Lots/Units Approved for Construction	975	970	412	430	2,787	4,117

**Food**

- Five staff members attended the 2018 Biennial Conference for Food Protection (CFP) in Richmond, VA. The CFP is a formal process whereby members of industry, regulatory, academia, consumer and professional organizations are afforded equal input in the development and/or modification of food safety guidance. This guidance is then incorporated into the FDA Food Code and other food safety laws and regulations. Funding for staff participation in the conference was provided by an FDA Voluntary National Retail Food Regulatory Program

Standards grant. Participation in the CFP meets criteria of Standard 7 – Industry and Community Relations.

- Three staff members attended the Nevada Food Safety Task Force – Nevada Environmental Health Association Conference held in Las Vegas. The conference provided the opportunity for participants to learn about new food safety and environmental health concerns and attendees included representatives from the food safety industry, food establishment operators and regulatory agencies in the state of Nevada. Funding for staff participation in the conference was provided by an FDA and Association of Food and Drug Officials (AFDO) grant.
- Due to the warmer weather, staff has seen an increase in waiver request and operational plan submittals for food establishments that wish to have dog friendly patios. The development of written policies addressing regulatory waiver requests related to foodborne illness risk factors meets the criteria of Standard 3 – Inspection Program Based on HACCP Principles
- **Special Events** – The first two large scale events of the year occurred in April (Lady Luck Tattoo Expo and Earth Day). Staff performed a total of 85 and 17 routine inspections, respectively. Eight different staff members volunteered to work at one or both of these events. Cinco de Mayo and the Reno River Festival are scheduled to occur in May and the temporary food permits will continue to increase through the summer.

### Land Development

- Development and cleanup of the workflows within Accela has resumed. All of the different plan review types are being reworked to be more efficient and more consistent with other workflows throughout the division. Once the redesign and testing are complete, the goal is to have all permit types within the Land Development team going through Accela.

<b>Land Development</b>	<b>JAN 2018</b>	<b>FEB 2018</b>	<b>MAR 2018</b>	<b>APR 2018</b>	<b>YTD 2018</b>	<b>2017 TOTAL</b>
Plans Received (Residential/Septic)	75	52	68	74	269	816
Residential Septic/Well Inspections	65	57	69	105	296	1,056
Well Permits	7	7	4	9	27	146

### Safe Drinking Water

- Staff went to an EPA modified training in Sacramento for sanitary surveys. The training was the final component the State wants its inspectors to complete. Several State staff members were there and positive discussion about ways to work together occurred. Additional networking was done with entities from California.
- The team is excited that the State seems to be looking into enforcing 120 day deadlines more rigorously. EHS had already begun improving its approach to enforcement and having the State be more involved with gaining compliance will make the process much simpler. It will also reinforce the message within the industry that deficiencies must be corrected in a timely fashion.

### Vector-Borne Diseases

- The average daily temperatures are not yet in the range to support disease transmission, but the stationery New Jersey light traps are collecting small numbers of Culex tarsaliis (primary vector of mosquito borne viruses species) and also higher numbers of Culiseta inornanta (also transmit viruses). Droplet testing of the foggers and Centaurs will be performed by Clarke Mosquito in order to confirm the correct droplet size is achieved for effectively controlling adult mosquito

populations. The Program's next helicopter larvaciding application with the product Vectolex is scheduled for June 6.

- Six public health officials from Brazil invited from the U. S. Department of State International Visitor Leadership Program visited WCHD to learn of the services provided to our Community. Staff provided a presentation on mosquito control, plague, rabies, Hanta virus, relapsing fever, bed bugs and improving infrastructure to reduce standing water as the services provided by the Program to our Community. The international group was shown the tools for surveillance in collecting adult mosquitoes, the laboratory for identifying mosquitoes, ticks and other insects and the products used for larvaciding control.
- The Program completed the interview process to fill two public health intern positions. After orientation, their training will begin to assist full-time staff in monitoring mosquito populations, perform surveillance activities, assist in treatment of small bodies of water and catch basins needing pesticide treatment, delivering mosquito fish and helping in the many requests we receive for abating mosquitoes. With the four intern positions filled and one returning from last year they will begin full-time activities the week of May 21.
- Vector Responses to Public Requests:

Vector Responses	JAN 2018	FEB 2018	MAR 2018	APR 2018	YTD 2018	2017 TOTAL
Mosquito	0	0	3	20	23	289
Mosquito Fish – Gambusia	0	0	0	5	5	124
Gambusia Delivered	0	0	0	0	0	807
Hantavirus	7	0	6	9	22	126
Plague	0	0	0	0	0	17
Rabies	3	4	1	4	12	104
Planning Calls	8	14	9	15	46	163
Lyme Disease/Ticks	1	0	1	4	6	26
Media	0	0	2	2	4	47
Outreach / Education / Misc.	9	11	13	28	61	442
Cockroach / Bedbug	3	7	9	9	28	227
West Nile Virus	0	0	0	0	0	55
Zika	0	0	0	0	0	12
<b>TOTAL</b>	<b>31</b>	<b>36</b>	<b>44</b>	<b>96</b>	<b>207</b>	<b>2,439</b>
<b>Planning Projects</b>	<b>6</b>	<b>15</b>	<b>13</b>	<b>16</b>	<b>50</b>	<b>149</b>

### Waste Management

- Household Hazardous Waste collection event is: Saturday, May 19, at 1455 E. Greg Street from 8:00 a.m. to 4:30 p.m.

### EHS 2018 Inspections

	JAN 2018	FEB 2018	MAR 2018	APR 2018	YTD 2018	2017 TOTAL
Child Care	11	11	4	6	32	115
Complaints	70	57	53	68	248	883
Food	650	724	709	625	2,708	4,997
General*	120	100	71	116	407	2,032
Temporary Foods/Special Events	17	19	25	59	120	1,686
Temporary IBD Events	2	0	1	85	88	96
Waste Management	6	29	14	16	65	286
<b>TOTAL</b>	<b>876</b>	<b>940</b>	<b>877</b>	<b>975</b>	<b>3,668</b>	<b>10,095</b>

\* **General Inspections Include:** Invasive Body Decorations; Mobile Homes/RVs; Public Accommodations; Pools; Spas; RV Dump Stations; and Sewage/Wastewater Pumping.

# HOUSEHOLD HAZARDOUS WASTE COLLECTION EVENT

SATURDAY, MAY 19, 2018  
8:00 AM TO 4:30 PM

Where: 1455 E. Greg Street, Sparks

First 50 pounds **free** for residential customers with  
accounts in good standing.  
All other residential HHW accepted at \$1.00 per pound.



## These items will be accepted at this free collection event:

- Televisions
- Laptops
- Printers
- VCRs
- Cell Phones
- Telephones
- Microwaves
- Radios/Stereos
- Prescription Medicines
- Used Oil and Filters
- Household Cleaners
- Medical Sharps
- Computer Monitors
- Computer Processing Units
- Fluorescent Lamps/Bulbs
- Mercury Thermometers
- Answering Machines
- Batteries (All Types)
- Paintings and Coatings
- Solvents, Glues and Chemicals
- Pool Chemicals
- Automotive Fluids
- Pesticides, Fungicides  
and Fertilizers

*Demand is expected to be very high.  
Event ends promptly at 4:30pm.  
Please arrive early to guarantee participation.*



**EPIDEMIOLOGY AND PUBLIC HEALTH PREPAREDNESS  
DIVISION DIRECTOR STAFF REPORT  
BOARD MEETING DATE: MAY 24, 2018**

**DATE:** May 10, 2018  
**TO:** District Board of Health  
**FROM:** Randall Todd, DrPH, EPHP Director  
775-328-2443, [rtodd@washoecounty.us](mailto:rtodd@washoecounty.us)  
**Subject:** Program Updates for Communicable Disease, Public Health Preparedness, Vital Statistics, and Emergency Medical Services

---

**Communicable Disease (CD)**

**Measles investigation** - The measles investigation has been closed. There were no secondary cases identified. The CD program received a total of 127 public contacts, either through phone calls or online survey. All were assessed using a screening form with 61 referred to Epi for further follow-up. A total of 79 contacts were identified that had actual exposure to the case either at a medical clinic, UNR campus building, or restaurant. Two contacts received IVIG Post-Exposure Prophylaxis. Nine contacts were tested and all were negative. Quarantine for nine contacts was recommended. For some, the quarantine was lifted after lab results were received. Two contacts had to be excluded from work and school and one contact from daycare. Six contacts required active daily monitoring by CD Program staff for signs and symptoms of measles. Hot wash meetings were conducted with staff and external partners to discuss what went well and what can be improved for the next response. Information gathered at these meetings will be compiled to revise protocols and response plans for future outbreaks.

**Presentation to Washoe County School District's school nurses** – On April 19, 2018, staff from the CD Program, EHS and CCHS presented to school nurses. Topics covered included an overview of the WCHD, disease reporting and investigation, outbreak overview, outbreak findings from past years, outbreak tools, the role of EHS in outbreaks, and Sexually Transmitted Disease among youth.

**Salmonellosis linked to Kratom Products** – On April 19, 2018, the CD Program was notified that a recently reported Salmonellosis case was linked to a multistate outbreak associated with Kratom products. Kratom is an opioid alternative. It is sold at local smoke shops and can also be purchased online. The case did consume the product during their incubation period. CD staff referred the case to EHS. They made contact with the store owner where the case had purchased the Kratom. Samples of the batch the case had consumed were still available and tested by the Nevada State Public Health Laboratory. The samples came back negative for Salmonella. The CDC opened the outbreak investigation in February. Currently there are 4 strains of Salmonella associated with this outbreak.



**Seasonal Influenza Surveillance** – For the week ending May 5, 2018 (CDC Week 18), twelve participating sentinel providers reported a total of 63 patients with influenza-like-illness (ILI). The percentage of persons seen with ILI by the 12 providers was 0.9% (63/6684) which is below the regional baseline of 2.4%. During the previous week (CDC Week 17), the percentage of visits to U.S. sentinel providers due to ILI was 1.5%. This percentage is below the national baseline of 2.2%. On a regional level, the percentage of outpatient visits for ILI ranged from 0.8% to 2.3%.

Six death certificates were received for week 18 listing pneumonia (P) or influenza (I) as a factor contributing to the cause of death. The total number of deaths submitted for week 18 was 82. This reflects a P&I ratio of 7.3%. The total P&I deaths registered to date in Washoe County for the 2017-2018 influenza surveillance season is 254. This reflects an overall P&I ratio of 8.2% (254/3091).

### **Public Health Preparedness (PHP)**

On April 19, 2018 the WCHD Medical Reserve Corps Volunteer Coordinator, along with WCHD's Emergency Manager, Arron Kenneston, conducted an overview of pre public health emergency preparedness procedures for a delegation of law enforcement officials visiting from Kazakhstan. After a tour the Emergency Operation Center and the Emergency Call Center a discussion followed on how Washoe County responds to emergency events and, in particular, how we utilize volunteers. The University of Nevada's Northern Nevada International Center arranged the visit under the auspices of the State Department.

On May 3, PHP staff completed the last of three Point of Dispensing (POD) Command Training events for Health District Staff. The training focused on assuming leadership roles in a POD during a public health emergency.

On May 4, PHP and EMS Staff in collaboration with Community Emergency Response Team (CERT) volunteers, setup the Inflatable Mobile Medical Facility (IMMF). Setup included the HVAC system, generators, triage equipment, lighting and miscellaneous equipment essential for operations. The exercise gave staff the opportunity to train and identify essential resources to ensure the IMMF was operational. The IMMF will be setup on June 21 and utilized to provide first aid from Medical Reserve Corps volunteers as part of the Community Reception Center exercise and Preparedness Expo with the City of Reno.

During the week of May 14 the Public Health Emergency Response Coordinator will participate in the Quad-County Coalition No-Notice Exercise as an evaluator. The exercise is designed to increase capability for a healthcare evacuation among Washoe County's neighboring counties without notice.

On May 14, PHP staff will participate in the PHP Partners Meeting at the University of Nevada, Reno. This meeting provides an opportunity for collaboration among public health preparedness programs across the state, increasing preparedness and response efforts.

During the week of May 21-25, the regional hospitals and first responders will participate in four decontamination trainings at the regional hospitals. Funding for this training is provided through the Local Emergency Planning Committee (LEPC) in partnership with REMSA and the Inter-Hospital Coordinating Council (IHCC).

### **Vital Statistics**

The Nevada Division of Public and Behavioral Health is revising the Nevada Administrative Code (NAC) Chapter 440 and will hold a workshop on May 24. The proposed changes to NAC relate to timely death reporting, clarification of the process for home births, facilitation and assistance to ensure accurate information on death records, clarification of the process for correcting birth and death records, and allowance for a coroner or medical examiner to correct medical information on death certificates if the death is being investigated by their agency.

### **Emergency Medical Services (EMS)**

The EMS Coordinator presented at the Sparks Citizens Advisory Committee (SCAC) meeting on April 12 about public health preparedness and response plans. The presentation included an overview of preparedness and how Health District personnel coordinate with a broad range of regional partners in all phases of plan development and implementation.

The EMS Coordinator held the final Multi-Causality Incident Plan (MCIP) and Alpha Plan review on April 17. The regional partners suggested some minor revisions to the plan which should be completed and presented to the DBOH in June 2018.

The EMS Coordinator facilitated the first Regional Protocol Review meeting on April 19. This was the first time the task force convened since the implementation of the Regional EMS Protocols. The group identified several small revisions to the protocols that will be executed July 1. The task force will also bring select items to the June Pre-hospital Medical Advisory Committee (PMAC) meeting for discussion and recommendations from the medical directors.

The EMS Coordinator presented at the Veterans Integrated Service Network (VISN) Emergency Management Conference on the Mutual Aid evacuation Annex (MAEA) on April 25. The presentation was for several VA Emergency Managers and provided an overview of how we would evacuate a healthcare facility in Washoe County.

The EMS Coordinator participated in the Annual Part 139 Tabletop exercise for the Reno-Tahoe International Airport on April 26. The tabletop scenario was an active shooter incident that involved approximately 90 casualties. It elicited great discussion about the MCIP and Regional Active Shooter Protocols amongst many regional agencies, including several airlines, airport staff, local first responders, the Red Cross, the FBI, the Medical Examiner's Office, and Public Health.

The EMS Program Manager and EMS Coordinator held the Low Acuity/Priority 3 meeting on May 1 to continue the discussion of the alpha level determinants that could receive an alternative response. The group reviewed 7 more determinants and selected whether or not an alternative response would be appropriate for the chief complaints. The group will continue to meet until all identified alpha determinants have been reviewed.

The EMS Program has been working with vendors and regional partners to launch the campaign about appropriate uses for 9-1-1 (Washoe County Health District Strategic Plan Initiative 2.2.5.1. The URLs [thinkbeforeyoudial.com](http://thinkbeforeyoudial.com) and [pienseloantesdemarcar.com](http://pienseloantesdemarcar.com) were launched on May 2. Social media sponsored advertisements and RTC bus panels will begin on May 14. Television advertisements will also play on KRNV in June.

The EMS Coordinator conducted MAEA and WebEOC training for Northern Nevada Adult Mental Health Services (NNAMHS) personnel on May 7. Six personnel received training on the evacuation process outlined in the MAEA and three personnel were trained in using WebEOC. EMS and PHP staff continue efforts to enhance the plan by including skilled nursing, long-term care, mental and behavior health facilities into the plan.

**REMSA Percentage of Compliant Responses  
 FY 2017 -2018**

Month	Zone A	Zone B	Zone C	Zone D	Zones B, C and D	All Zones
July 2017	93%	88%	100%	100%	91%	93%
August 2017	93%	94%	91%	100%	93%	93%
September 2017	92%	96%	100%	100%	97%	92%
October 2017	92%	92%	91%	100%	92%	92%
November 2017	92%	93%	100%	100%	96%	92%
December 2017	92%	95%	87%	100%	93%	92%
January 2018	93%	94%	96%	100%	95%	93%
February 2018	92%	96%	97%	100%	96%	92%
March 2018	91%	90%	97%	100%	93%	91%
April 2018	93%	98%	91%	100%	96%	93%
<b>YTD</b>	<b>92%</b>	<b>94%</b>	<b>95%</b>	<b>100%</b>	<b>94%</b>	<b>92%</b>

**REMSA 90<sup>th</sup> Percentile Responses**

Month	Zone A 8:59	Zone B 15:59	Zone C 20:59	Zone D 30:59
July 2017	8:18	16:56	18:14	N/A*
August 2017	8:29	14:51	15:28	N/A*
September 2017	8:32	13:06	18:30	N/A*
October 2017	8:31	14:15	19:32	N/A*
November 2017	8:33	13:01	17:42	N/A*
December 2017	8:41	14:06	21:43	N/A*
January 2018	8:31	14:51	16:02	N/A*
February 2018	8:39	14:37	15:28	N/A*
March 2018	8:50	15:15	19:29	N/A*
April 2018	8:28	13:01	19:41	N/A*

\*There were 5 or less calls per month in Zone D, therefore a statistically meaningful 90<sup>th</sup> percentile analysis cannot be conducted. However, no calls in Zone D exceeded the 30:59 time requirement.

DHO	<u>KD</u>	
-----	-----------	--

**District Health Officer Staff Report  
Board Meeting Date: May 24, 2018**

**TO:** District Board of Health  
**FROM:** Kevin Dick, District Health Officer  
(775) 328-2416, kdick@washoecounty.us  
**SUBJECT:** District Health Officer Report – FY19 Budget, Water Projects, Public Health Accreditation, Community Health Improvement Plan, Truckee Meadows Healthy Communities, Quality Improvement Team, Workforce Development, Smoke Free Workplaces, REMSA Board Resignation, New CCHS Fees, Brazilian Delegation, Other Events and Activities and Health District Media Contacts.

---

FY19 Budget

The May 22, 2018 Board of County Commissioners agenda will include adoption of the FY19 Budget. It is anticipated to include adoption of the FY19 Health District Budget adopted by the District Board of Health in February with the exception of the above-base request for county general funds to provide additional mosquito abatement chemical applications.

Water Projects

NDEP has scheduled workshops for May 17 in Carson City, and May 18 in Las Vegas to solicit comments on regulatory amendments proposed for sections of the “Design, Construction, Operation and Maintenance of Public Water Systems” NAC 445A.65505 through NAC 445A.6731. Proposed changes include modifications to:

- General Definitions: NAC 445A.65845; NAC 445A.66375; NAC 445A.66395;
- Water Project Approval Requirements: NAC 445A.6671; NAC 445A.5403 (repeal);
- Lead-Free and Drinking Water Compatibility Requirements: NAC 445A.66085; NAC 445A.65825;
- Standards Adopted by Reference and Requirements: NAC 445A.6663; NAC 445A.66685;
- Distribution System Separation and Crossing Requirements: NAC 445A.6715; NAC 445A.67105; NAC 445A.67155; NAC 445A.6716; NAC 445A.67165; NAC 445A.6717; NAC 445A.67175; NAC 445A.67185; and
- Backflow Prevention Requirements: NAC 445A.6719; NAC 445A.67215.

The proposed amendments are planned to be presented for adoption to the State Environmental Commission on June 27, 2018.

NDEP, TMWA, and the Health District are working to formulate an interlocal agreement to provide for an alternative approach to oversight of water projects that are reviewed by TMWA for the TMWA NV0000190 system, while still providing oversight in conformance with Federal and State requirements to provide the protections of the Safe Drinking Water Act and Nevada Safe Drinking Water Statutes.

### Public Health Accreditation

The Accreditation team received largely positive feedback from the “pre-review check”, where documents were submitted for review prior to the full submission of all documents. Two items submitted needed minor revisions and the requested revisions were shared with the team for further understanding of the format of the documentation needed and corresponding description. The team continues to meet monthly to review current progress and discuss challenges, and one-on-one monthly meetings are being held with team members who have not yet completed all their assigned documents. We now have about 128 of the required documents gathered of the needed 213.

A revised style guide was developed and distributed to staff along with templates for presentations, manuals and letterhead in order to improve consistency of formatting and correct logo usage.

### Community Health Improvement Plan

Development of the 2018-2020 CHIP continues with the identified focus areas of Housing, Behavioral Health and Nutrition/Physical Activity. Two draft action plans have been completed for Housing, and the Nutrition/Physical Activity Committee has developed five draft action plans that are being circulated for final edits. Five Behavioral Health action plans have drafted and circulated amongst stakeholders for feedback. All action plans have a target completion date of May 25<sup>th</sup>.

### Truckee Meadows Healthy Communities

Housing: Development of the Regional Affordable Housing Strategy with Enterprise Community Partners and Truckee Meadows Regional Planning Agency continues. Representatives from Enterprise visited in early May and the Executive Leadership Team, Public Staff, and Community Leadership Working Groups continue to meet. Fundraising for Phase II of the project has been completed. Results of the Phase I project work will be presented during the June 14, 2018 TMRPA Governing Board Meeting and during a community meeting that evening.

### Quality Improvement Team

The QI team will be meeting on the 22<sup>nd</sup> of May to revise the annual QI survey in order to get better feedback on how we can improve QI across the Health District.

Attached please find the results from the QI survey distributed to staff. Staff response was lower than in past years. The only responses which were statistically significantly different from previous years were:

- Leadership - “Innovation and new ideas are encouraged”, a lower percentage responding affirmatively compared to previous years
- Coworkers - “Show confidence and trust in each other”, a higher percentage responding affirmatively compared to previous years
- Coworkers - “Expect a high quality job from themselves and others”, a higher percentage responding affirmatively compared to previous years

### Workforce Development

We are working to finalize a contract to be able to provide training to Health District staff by Dr. Mel Minarik in June. We will be partnering with the County as well, and limited seats will be available for county staff.

Title: Learning Organizations: Create Your Future Through a Positive Thinking Framework

Description: Want to learn how to better adapt to rapidly evolving situations through a positive thinking framework? This two hour long session will focus on sharing information on the principles of a learning organization and how you can use that framework to adapt to changes. The five key principles of a learning organization will be discussed along with the basic steps in the appreciative inquiry process which can be used to shape the steps needed to accomplish a goal.

### Smoke Free Workplaces

Other Health District staff and I attended a meeting hosted by the American Heart Association and the Nevada Tobacco Prevention Coalition (NTPC) on May 3 regarding smoke free workplaces. Workplaces exempt from the Nevada Clean Indoor Air Act (NCIAA) were discussed, along with the impacts on the workforce in these businesses, and studies that have been conducted by the National Institute of Occupational Safety and Health (NIOSH) in Southern Nevada, and Tufts/Stanford in Northern Nevada related to secondhand smoke in casinos. NTPC presented information on their advocacy agenda of opportunities to improve the NCIAA which include eliminating employee second-hand smoke exposure by removing exemptions to the Act.

### REMSA Board Resignation

District Board of Health REMSA Board Consumer Representative appointee Mr. Jim Begbie has resigned his position on the REMSA Board effective July 1, 2018. The volunteer opportunity will be posted on the Washoe County website and candidates will be presented for DBOH consideration.

### New CCHS Fees

On April 18, 2018 the Health District added a new Oral Contraceptive approved by Dr. Passalacqua to the fee schedule. The fee is \$0.10 per cycle for Microgestin 28 day with iron (1mg norethindrone/0.02 mg ethinyl estradiol).

### Brazilian Delegation

A delegation of health officials from Brazil, hosted by the Northern Nevada International Center (NNIC), visited Reno on April 26 and 27th to learn how the County coordinates the communicable disease reporting system and the investigation, control and prevention of disease. The delegates learned about recent disease outbreaks and the County's response.

County representatives and presenters to the group included:

- Kerry Chalkley, WCHD Epidemiologist on Disease Surveillance
- Aaron Kenneston, Washoe County Emergency Manager on EOC Operations
- James Shaffer, WCHD Vector Borne Disease Prevention Program Manager on Vector Control
- Phillip Ulibarri, WCHD Communications Manager on CDC and ICS Crisis Communication principles

NNIC informed, "Our delegates had only positive things to say about the meeting with you and mentioned that they felt like you had answered any and all questions very clearly and in depth. On behalf of the NNIC, we are always happy to hear that and want to extend our thanks as well!"

### Other Events and Activities

4/30/18	REMSA Board Meeting
4/30/18	Nevada Public Health Foundation Board of Director's Meeting
5/2/18	TMHC Board of Director's Meeting
5/2/18	Division Directors and Supervisors Meeting
5/3/18	Smoke-Free Workplaces Meeting
5/3/18	Traner Middle School Mural Unveiling
5/3/18	NV Health Authorities Conference Call
5/4/18	Monthly Meeting with Dave Solaro
5/4/18	Water Project Interlocal Agreement Meeting
5/7/18	Measles Hot Wash: Command Staff Meeting
5/8/18	Measles Hot Wash: External Partners
5/8/18	TMHC/TMRPA/Enterprise Meeting
5/9/18	Department Heads Meeting
5/9/18	CCHS – DHO/DD/Board Member Meeting
5/11-5/22/18	Vacation
5/23/18	Division Directors Meeting
5/23/18	Nevada Association of Local Health Officials Meeting

# Staff Quality Improvement Survey Results

## Question #1

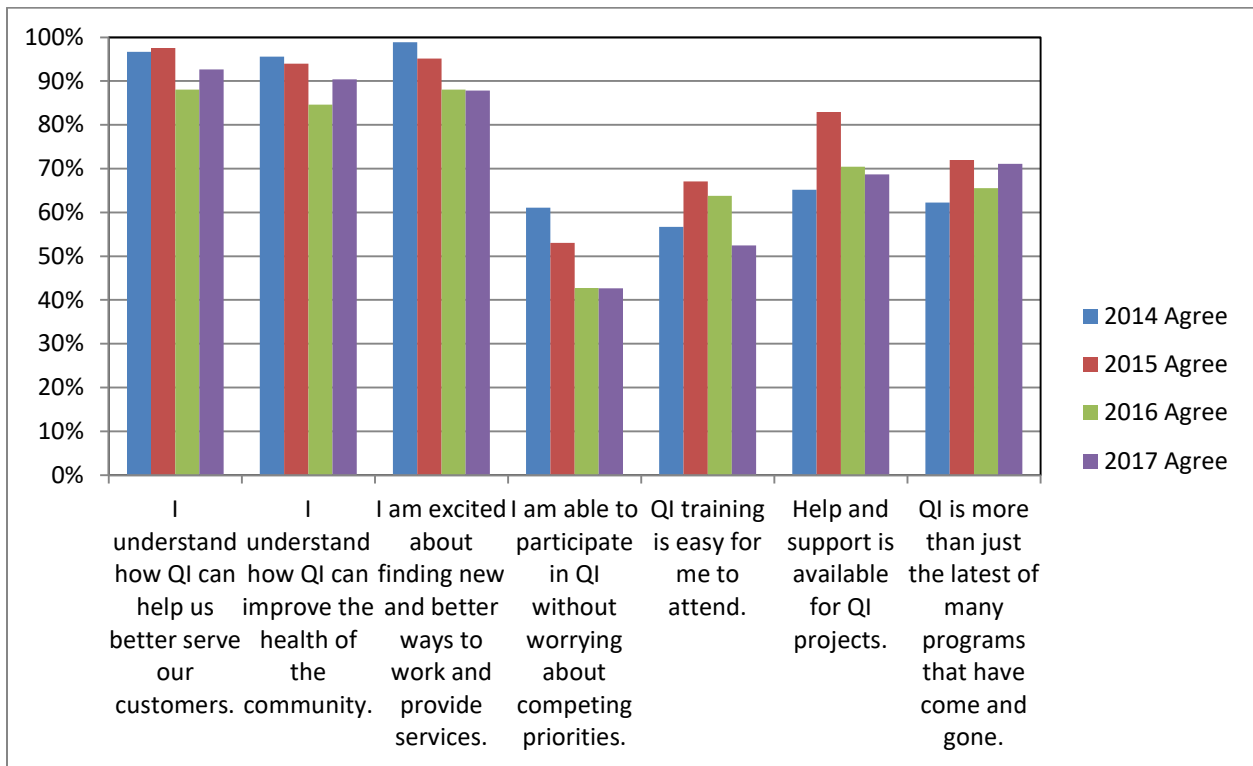



Question #2

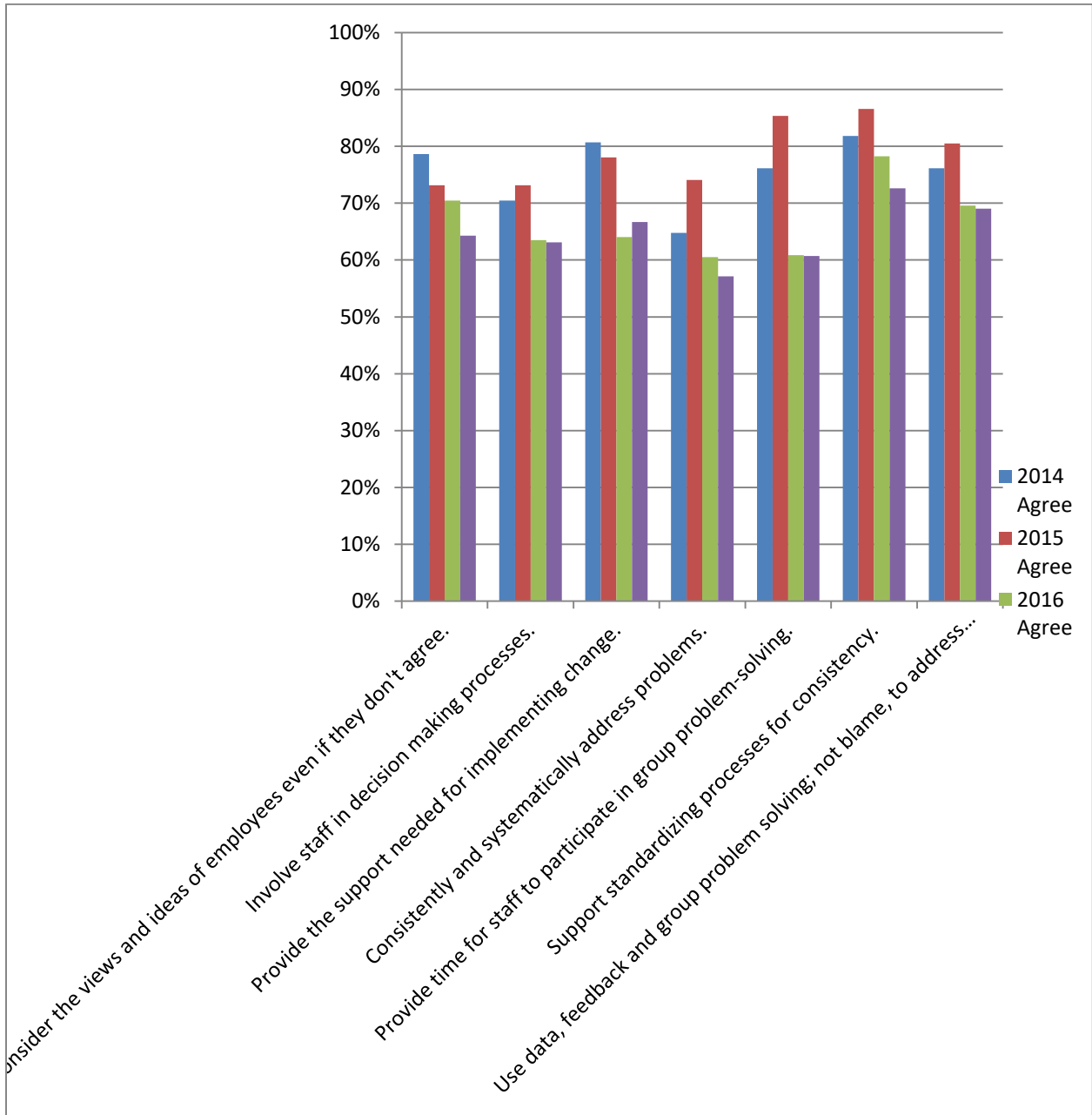

Question #3

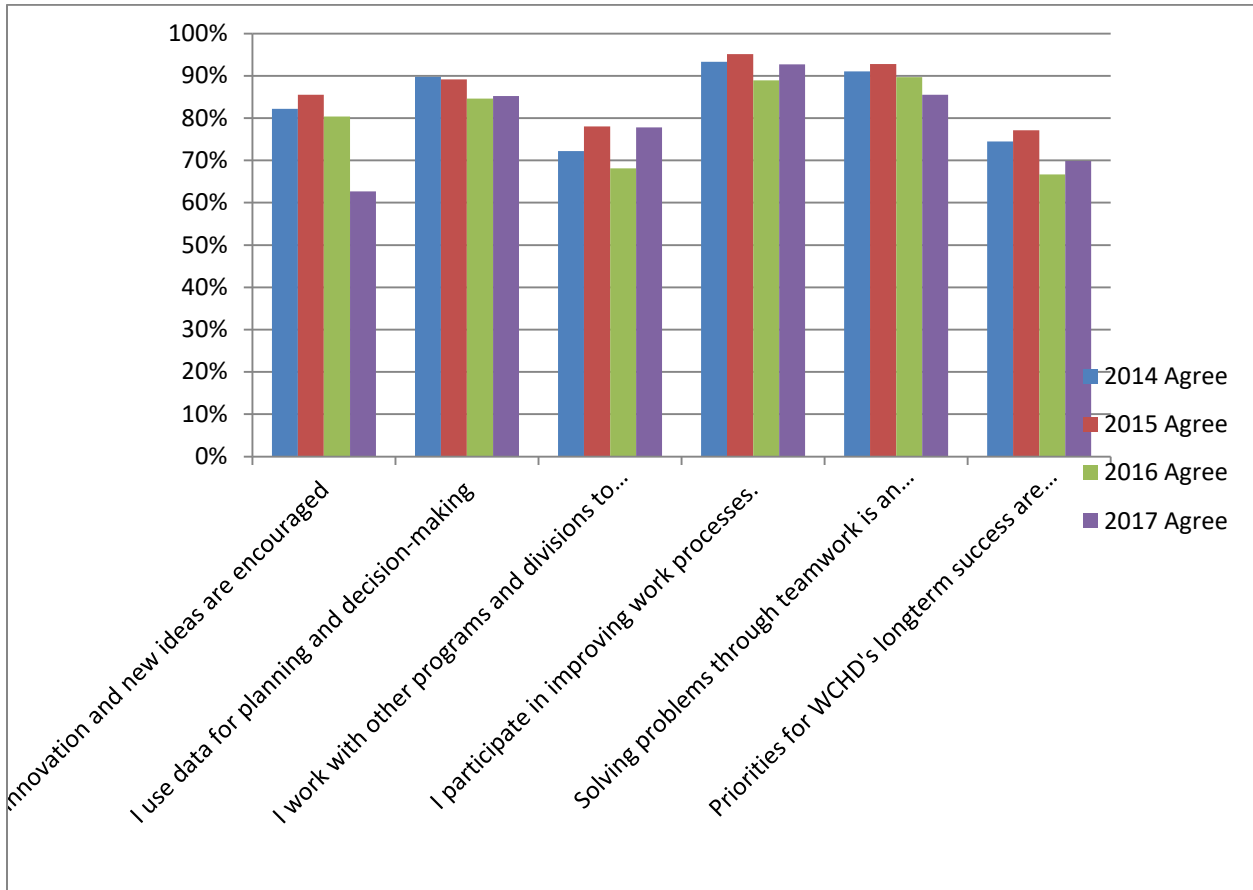

Question #4

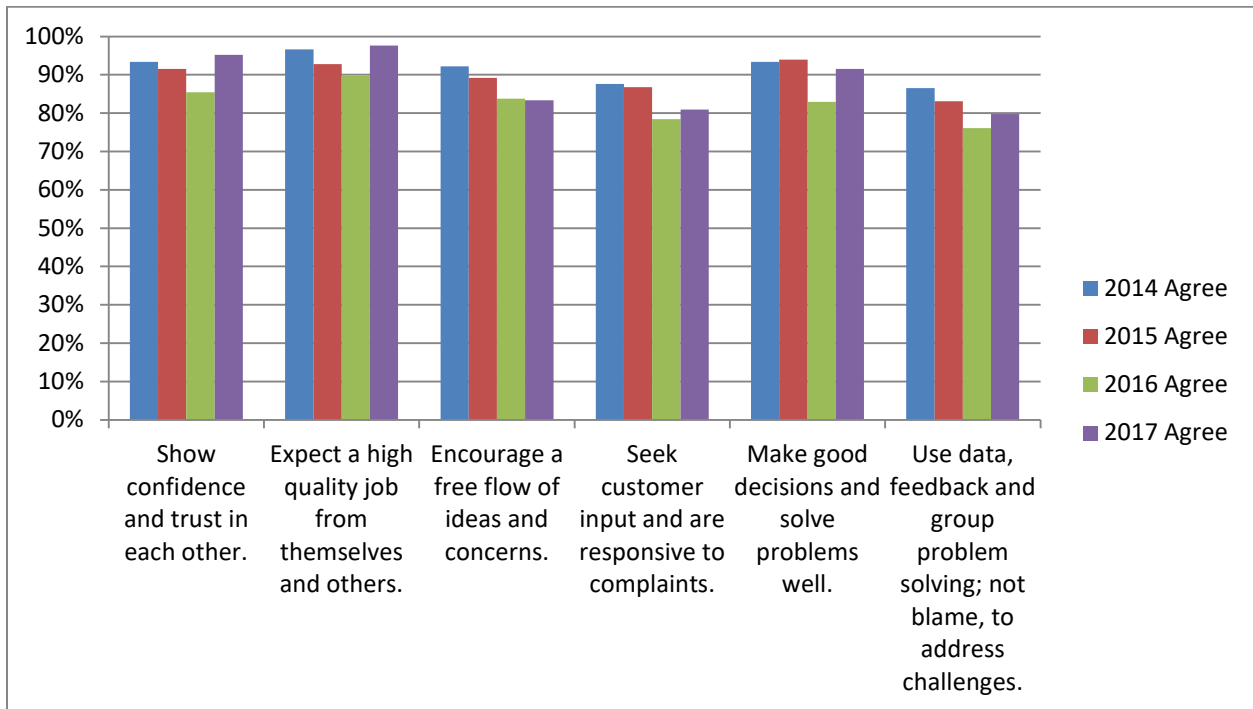

**Health District Media Contacts: April 2018**

<u>DATE</u>	<u>MEDIA</u>	<u>REPORTER</u>	<u>STORY</u>
4/25/2017	KTVN CH2 - CBS Reno	John Potter	Mosquitos - Ulibarri/Shaffer
4/25/2017	KTVN CH2 - CBS Reno	Jaimi Hayes	Mosquitos - Ulibarri/Shaffer
4/24/2018	KRNV CH4 - NBC Reno	Ryan Curry	Kratom - Westom
4/24/2018	KOLO CH8 - ABC Reno	Denise Long	Kratom - Ulibarri
4/24/2018	KRNV CH4 - NBC Reno	Ryan Curry	Mosquitos - Ulibarri/Shaffer
4/19/2018	Reno Gazette-Journal	Marcela Corona	PM10 - Schnieder
4/18/2018	KTVN CH2 - CBS Reno	Gene Vance	CHIP Report - Peters
4/16/2018	German Public Television	Michael Wech	NDM-CRE - Ulibarri/Todd/Chen
4/9/2018	Reno Gazette-Journal	Siobhan McAndrew	Measles - Ulibarri
4/9/2018	KRNV CH4 - NBC Reno	Melissa Metheney	Meth - Ulibarri
4/9/2018	UNIVISION	Anya Archeya	Meth - Ulibarri
4/5/2018	Reno Gazette-Journal	Siobhan McAndrew	Measles - Holmsted/Ulibarri
4/5/2018	Reno News & Review	Luka Starmer	Healthy Living Mural - Bogale
4/5/2018	KOLO CH8 - ABC Reno	Terri Russell	Chronic Disease Report Card - Chen
4/5/2018	KUNR 88.7AM - NPR Reno	Anh Gray	Measles - Todd
4/4/2018	UNIVISION	Carolina Lopez	Measles - Todd
4/4/2018	KRNV CH4 - NBC Reno	Kristen Edwards	Measles - Todd
4/4/2018	KTVN CH2 - CBS Reno	Chris Buckley	Measles - Todd
4/4/2018	KOLO CH8 - ABC Reno	Gurajpal Sangha	Measles - Todd
4/2/2018	UNIVISION	Anya Archeya	Chronic Disease Report Card - Chen

**Press Releases/Media Advisories/Editorials/Talking Points**

4/25/2018	Community to celebrate new neighborhood mural	Ulibarri	
4/24/2018	First mosquito abatement operation of 2018 starts Wednesday	Ulibarri	
4/24/2018	Health District identifies recalled Kratom products	Ulibarri	
4/18/2018	Washoe County Health District releases Annual Report	Ulibarri	
4/18/2018	Health District releases CHIP Annual Report	Ulibarri	
4/9/2018	Treat Me Right	Ulibarri	
4/4/2018	Washoe County Health District reports measles case	Ulibarri	
	<b>Facebook</b>	AQMD/CCHS/ODHO EHS	104 (CCHS 24 EHS 16 ODHO 5 AQM 59)
	<b>Twitter</b>	AQMD/CCHS	54 (AQM 51 CCHS 3)